

Text-Books of Physical Chemistry

EDITED BY

SIR WILLIAM RAMSAY, K.C.B., F.R.S.

Cornell University Library

BOUGHT WITH THE INCOME
FROM THE
SAGE ENDOWMENT FUND
THE GIFT OF
Henry W. Sage
1891

A.287713

26/VII/14

arV1325 Cornell University Library

Metallography.



3 1924 031 240 595
olin,anx



Cornell University Library

The original of this book is in
the Cornell University Library.

There are no known copyright restrictions in
the United States on the use of the text.

TEXT-BOOKS OF PHYSICAL
CHEMISTRY

EDITED BY SIR WILLIAM RAMSAY, K.C.B., F.R.S.

METALLOGRAPHY

TEXT-BOOKS OF PHYSICAL CHEMISTRY.

EDITED BY SIR WILLIAM RAMSAY, K.C.B., F.R.S., D.Sc.

- STOICHIOMETRY. By SYDNEY YOUNG, D.Sc., F.R.S., Professor of Chemistry in the University of Dublin; together with an INTRODUCTION TO THE STUDY OF PHYSICAL CHEMISTRY, by Sir WILLIAM RAMSAY, K.C.B., F.R.S., Editor of the Series. Crown 8vo. 7s. 6d.
- CHEMICAL STATICS AND DYNAMICS, including THE THEORIES OF CHEMICAL CHANGE, CATALYSIS AND EXPLOSIONS. By J. W. MELLOR, D.Sc. (N.Z.), B.Sc. (Vict.). Crown 8vo. 7s. 6d.
- THE PHASE RULE AND ITS APPLICATIONS. By ALEX. FINDLAY, M.A., Ph.D., D.Sc., Lecturer and Demonstrator in Chemistry, University of Birmingham. With 134 Figures in the Text. Crown 8vo. 6s.
- SPECTROSCOPY. By E. C. C. BALY, F.I.C., Lecturer on Spectroscopy and Assistant Professor of Chemistry, University College, London. With 163 Illustrations. Crown 8vo. 12s. 6d.
- THERMOCHEMISTRY. By JULIUS THOMSEN, Emeritus Professor of Chemistry in the University of Copenhagen. Translated by KATHARINE A. BURKE, B.Sc. (Lond.), Assistant in the Department of Chemistry, University College, London. Crown 8vo. 9s.
- ELECTRO-CHEMISTRY. PART I.—GENERAL THEORY. By R. A. LEHFELDT, D.Sc., Professor of Physics at the East London Technical College. Including a Chapter on the Relation of Chemical Constitution to Conductivity, by T. S. MOORE, B.A., B.Sc., Lecturer in the University of Birmingham. Crown 8vo. 5s.
- PART II.—APPLICATIONS TO ELECTROLYSIS, PRIMARY AND SECONDARY BATTERIES, etc. By N. T. M. WILSMORE, D.Sc.
[In preparation.]
- STEREOCHEMISTRY. By A. W. STEWART, D.Sc., Carnegie Research Fellow, Lecturer on Stereochemistry in University College, London. With 87 Illustrations. Crown 8vo. 10s. 6d.
- THE THEORY OF VALENCY. By J. NEWTON FRIEND, Ph.D. (Würz.), M.Sc. (Birmingham). Crown 8vo. 5s.
- METALLOGRAPHY. By CECIL H. DESCH, D.Sc. (Lond.), Ph.D. (Würzb.), Graham Young Lecturer in Metallurgical Chemistry in the University of Glasgow. Crown 8vo. 9s.
- THE RELATIONS BETWEEN CHEMICAL CONSTITUTION AND SOME PHYSICAL PROPERTIES. By SAMUEL SMILES, D.Sc., Fellow of and Assistant Professor of Organic Chemistry at University College, London. 14s.
- PHOTOCHEMISTRY. By S. E. SHEPPARD, D.Sc.
- THERMODYNAMICS. By F. G. DONNAN, M.A., Ph.D., F.R.S., Professor of General Chemistry at the University College, London.
- PRACTICAL SPECTROGRAPHIC ANALYSIS. By J. H. POLLOK, D.Sc.
- CRYSTALLOGRAPHY. By T. V. BARKER, B.Sc., M.A., Fellow of Brasenose College, Oxford.

LONGMANS, GREEN, AND CO.

39, PATERNOSTER ROW, LONDON

NEW YORK, BOMBAY, AND CALCUTTA

METALLOGRAPHY

BY

CECIL H. DESCH

D.SC. (LOND.), PH.D. (WÜRZB.)

GRAHAM YOUNG LECTURER IN METALLURGICAL CHEMISTRY
IN THE UNIVERSITY OF GLASGOW

WITH 14 PLATES

AND 108 DIAGRAMS IN THE TEXT

SECOND EDITION

LONGMANS, GREEN, AND CO.

39 PATERNOSTER ROW, LONDON

NEW YORK, BOMBAY, AND CALCUTTA

1913

All rights reserved.

A.287713

DEDICATED
TO
MY FATHER AND MOTHER

PREFACE

THE study of metallic alloys by physical and microscopical methods has reached so great a development in recent years as to form a distinct branch of physical chemistry. In the following pages I have sought to present an account of the methods employed in this branch of study, and of the conclusions which have been reached, and also to indicate the directions in which further research is needed. The attempt has been made to discriminate, in the literature of the subject, between investigations performed with the requisite care and thoroughness, and those which, from the use of impure materials in preparing the alloys, the examination of insufficiently large quantities, or other causes, fail to reach the standard of accuracy required in physico-chemical work.

The abbreviations employed in the footnotes are, in most cases, those adopted by the Chemical Society, and the remainder will, it is hoped, be self-explanatory. References to Russian periodicals are only given if the investigation has not been published in full in another language.

The whole of the photo-micrographs have been prepared in the Metallurgical Laboratory of the University of Glasgow.

I take this opportunity of expressing my thanks to Dr. J. G. Gray and Mr. A. D. Ross, of the Physical Laboratory of this University, who have kindly read in proof the section on the magnetic properties of alloys, to Prof. A. K. Huntington for facilities afforded me when working in the Metallurgical

Laboratory of King's College, London, and to Messrs. R. and J. Beck, Messrs. W. Watson & Sons, Messrs. Carl Zeiss, London, Messrs. J. Carling & Sons, Middlesbrough, and Messrs. W. W. Scott & Co., Glasgow, for the use of blocks illustrating apparatus.

Lastly, I wish to acknowledge the constant assistance of my wife, both in the experimental work and in the preparation of the text.

C. H. D.

THE UNIVERSITY,
GLASGOW.

NOTE TO THE SECOND EDITION

WHILST the general plan and arrangement of the first edition of this work are unchanged, the text has been revised throughout, for the purpose of removing errors, of incorporating the most important results of recent investigations, and of completing the references to publications. The most important changes have been made in the chapters dealing with the physical properties of alloys (Chap. XII.) and with the metallography of iron and steel (Chap. XVII.) The appendix has been completely revised, and incorporates publications received down to the time of going to press.

C. H. D.

GLASGOW,
March, 1913.

CONTENTS

	PAGE
CHAPTER I	
INTRODUCTION	1
CHAPTER II	
THE DIAGRAM OF THERMAL EQUILIBRIUM	12
CHAPTER III	
THE DIAGRAM OF THERMAL EQUILIBRIUM (<i>continued</i>)	43
SOLID SOLUTIONS OR MIXED CRYSTALS.	
CHAPTER IV	
THE DIAGRAM OF THERMAL EQUILIBRIUM (<i>continued</i>)	65
TERNARY AND MORE COMPLEX SYSTEMS.	
CHAPTER V	
THE DIAGRAM OF THERMAL EQUILIBRIUM (<i>continued</i>)	81
METALS WHICH ARE ONLY PARTIALLY MISCIBLE IN THE LIQUID STATE.	
CHAPTER VI	
PRACTICAL PYROMETRY AND THERMAL ANALYSIS	94
CHAPTER VII	
THE PREPARATION OF MICRO-SECTIONS	134
CHAPTER VIII	
THE MICROSCOPICAL EXAMINATION OF PREPARED SECTIONS	154

	PAGE
CHAPTER IX	
THE CRYSTALLIZATION OF METALS AND ALLOYS	175
CHAPTER X	
UNDERCOOLING AND THE METASTABLE STATE	197
CHAPTER XI	
DIFFUSION IN THE SOLID STATE	216
CHAPTER XII	
THE PHYSICAL PROPERTIES OF ALLOYS	230
DENSITY—THERMAL EXPANSIBILITY—HARDNESS—ELECTRICAL CONDUCTIVITY—THERMO-ELECTRIC POWER—MAGNETIC PROPERTIES.	
CHAPTER XIII	
ELECTROMOTIVE FORCE AND CORROSION	276
CHAPTER XIV	
THE CONSTRUCTION OF THE EQUILIBRIUM DIAGRAM	299
CHAPTER XV	
THE MOLECULAR CONDITION OF METALS IN ALLOYS AND THE NATURE OF INTER-METALLIC COMPOUNDS	328
CHAPTER XVI	
THE PLASTIC DEFORMATION OF METALS AND ALLOYS	341
CHAPTER XVII	
THE METALLOGRAPHY OF IRON AND STEEL	361
CHAPTER XVIII	
THE METALLOGRAPHY OF INDUSTRIAL ALLOYS	386
APPENDIX	
LIST OF SYSTEMS	399
INDEX	419

LIST OF PLATES

		TO FACE PAGE
I.	{	A. SURFACE OF TIN INGOT 177
	{	B. ETCHED SURFACE OF TIN 177
II.	{	A. ALLOY OF COPPER AND NICKEL 182
	{	B. BRASS 182
III.	{	A. ALLOY OF COPPER AND SILVER 183
	{	B. ALLOY OF COPPER AND ANTIMONY 183
IV.	{	A. EUTECTIC ALLOY OF COPPER AND PHOSPHORUS . 185
	{	B. EUTECTIC ALLOY OF COPPER AND PHOSPHORUS . 185
V.	{	A. ALLOY OF BISMUTH AND TIN 186
	{	B. ALLOY OF BISMUTH AND LEAD 186
VI.	{	A. ALLOY OF COPPER AND ANTIMONY 187
	{	B. ALLOY OF COPPER AND ANTIMONY 187
VII.	{	A. ALLOY OF COPPER AND ANTIMONY 188
	{	B. ALLOY OF ANTIMONY AND TIN 188
VIII.	{	A. ALLOY OF COPPER AND ALUMINIUM 190
	{	B. ALUMINIUM BRONZE 190
IX.	{	A. ALLOY OF COPPER AND ZINC 191
	{	B. ALLOY OF LEAD, TIN, AND BISMUTH 191
X.	{	A. DIFFUSION OF ZINC IN COPPER 221
	{	B. DIFFUSION OF ZINC IN COPPER 221
XI.	{	A. SLIP-BANDS IN LEAD 346
	{	B. PEARLITE 346
XII.	{	A. SCRATCHED SURFACE OF BISMUTH 355
	{	B. PARTLY POLISHED SURFACE OF BISMUTH 355
XIII.	{	A. SOFT IRON 369
	{	B. SOFT STEEL 369
XIV.	{	A. WHITE PIG IRON 376
	{	B. EUTECTIC OF WHITE PIG IRON 376

METALLOGRAPHY

CHAPTER I

INTRODUCTION

METALLOGRAPHY may be defined as the study of the internal structure of metals and alloys, and of its relation to their composition, and to their physical and mechanical properties. It is a branch of physical chemistry, since the internal structure depends on the physical and chemical conditions under which the solid metal or alloy is formed, and the study of structure presents itself as a department of the study of equilibrium in heterogeneous systems. Whilst, however, physical chemistry concerns itself in general only with the nature and relative quantity of the phases in a system, and with the transformations of energy which accompany chemical changes, metallography takes into account a further variable, namely, the mechanical arrangement of the component particles. It is thus intimately connected with crystallography.

The consideration of metals and alloys as a class apart from other mixtures and solutions which obey the same physico-chemical laws is partly an historical accident, and arises partly from the great importance of the metals in technical practice. The needs of practical metallurgy, especially in the iron and steel industries, have been the motive of the earliest, and of many of the most important metallographic investigations. The study of structure has proved itself an indispensable auxiliary to chemical analysis in the scientific control of the metallurgical industries, an auxiliary of which the applications become more extensive and more important every year. But from the standpoint of pure science, the identity of the relations in metallic and non-metallic systems must not be overlooked.

Geologists and mineralogists are now making use of the methods and results of metallography to study the formation and metamorphosis of igneous rocks, whilst light is being thrown from the same source into the hitherto obscure region of the cements and slags, and the science is capable of still further extension.

The word "metallography" was formerly used¹ to signify the description of metals and their properties. In this sense it is obsolete, although an isolated example of its use is found as late as 1871.² Its reintroduction to designate the microscopic structure of metals and alloys dates only from 1892,³ since when it has been generally accepted, gradually receiving an extension of meaning to include investigations by other than microscopical means.

The examination of metals by means of the microscope, so recent as a method of systematic research, was nevertheless practised by several of the older investigators. As far back as 1665, Robert Hooke, in his *Micrographia*, described the appearance of lead crystallizing from its alloy with silver, and further described and drew the magnified surface of a polished steel blade, adding some thoughtful remarks on the nature of polish.⁴

Réaumur, in 1722,⁵ employed the microscope to examine the fractured surfaces of steel and of white and grey cast-iron, founding on the results which he obtained a method of distinguishing between irons subjected to different thermal treatments. An extract will show the nature of his observations:—

P. 392: "Si on examine les unes et les autres fontes au microscope, les fontes bien blanches y parôitront toujours d'une

¹ The earliest instance of its use given in the *New English Dictionary*, Oxford, is dated 1721.

² T. A. Blyth, *Metallography as a Separate Science*, London, 1871.

³ F. Osmond, *Rapport présenté à la commission des méthodes d'essais des matériaux*, February, 1892.

⁴ Robert Hooke, *Micrographia; or, Some Physiological Descriptions of Minute Bodies made with Magnifying Glasses, with Observations and Enquiries thereon*, London, 1665.

⁵ R. A. F. de Réaumur, *L'Art de convertir le fer forgé en acier, et l'art d'adoucir le fer fondu*, Paris, 1722.

tissure compacte, on y pourra observer quelques lames plates parsemées, mais beaucoup plus petites que celles de l'acier, la même loupe qui fait apercevoir celles dont sont composés les grains d'un acier trempé peu chaud, ne feroit pas appercevoir celles-cy. Les fontes grises paroissent au microscope d'un tissu tellement spongieux, que tout semble un amas d'especes de cristallisations, ou si l'on veut de brössailles, des especes de vegetations chimiques, faites d'une infinité de branchages entrelassés, mais composés chacun de petites lames agencées les unes sur les autres."

Réaumur suggests in the same work, one of the most important in the early history of iron, a polyhedral arrangement of the crystals, and puts forward a theory to explain the hardening effect of quenching steel. The very numerous drawings testify to the careful character of his observations.

The microscopical examination of fractured surfaces is of very limited application, and is unsuitable for systematic study. The way towards a better method was opened by the discovery of Widmanstätten, in 1808,¹ that certain meteorites when cut and polished develop a distinct and characteristic structure on being etched with acids, or oxidized by heating in air. Widmanstätten's figures being visible without magnification, the process was not extended to metals having a more minute structure, and metallography made no further progress for many years. In 1864, H. C. Sorby, of Sheffield, who may also be regarded as the founder of the modern science of microscopical petrography, was led from the study of rocks and meteorites to that of iron and steel. His early publications on the subject were confined to brief notes,² although his specimens and photographs, exhibiting the constituents of iron and steel, were shown in Sheffield and at the Bath meeting of the British Association. Sorby was successful in devising a suitable technique for the preparation and examination of

¹ A. J. F. X. von Widmanstätten did not publish any account of these experiments, which are described by Schreibers, *Meteorische Stein- u. Metallmassen*, i. 20 (Vienna, 1820).

² *Proc. Sheffield Lit. Phil. Soc.*, 1864, Feb.; *Brit. Assoc. Rep.*, 1864, ii. 189.

microscopic sections, and his later publications¹ contain photomicrographs which have hardly been surpassed in excellence by later workers. Sorby is certainly entitled to the credit of being the founder of metallography, although his early observations remained almost unnoticed for twenty years, by which time similar results had been attained by workers in other countries.

Attempts had been made² to examine metals by cutting thin sections similar to those used in the study of rocks. It is not possible to examine such sections by transmitted light, however thin the sections may be cut, and the plan was therefore adopted of subjecting the sections to the attack of reagents, so as to dissolve out certain constituents, leaving the residue in the form of a spongy network. This method is not very valuable, and beyond demonstrating the fact that iron or steel containing carbon has a cellular structure, little information was obtained by its means.

In 1878, the first communications from the Charlottenburg Testing Laboratory appeared.³ The work of Martens is independent of that of Sorby, and has contributed very materially to the progress of the science. He was followed by Wedding,⁴ Stein,⁵ and Osmond.² All these investigators, confining themselves at first to iron and steel, aimed at the discovery of a means of controlling the quality and composition of manufactured products. The work of Osmond and Werth was of special value in showing the ways in which carbon, phosphorus, and other elements are distributed through the metal, means being found, for the first time, of distinguishing between intercellular and intracellular constituents. The

¹ *Engineer*, 1882, 54, 308; *J. Iron Steel Inst.*, 1886, i. 140; 1887, i. 255.

² F. Osmond and J. Werth, *Compt. rend.*, 1885, 100, 450; *Ann. Mines*, 1885, [viii.] 8, 1.

³ A. Martens, *Zeitsch. Ver. deut. Ing.*, 1878, 22, 11, 206, 480; 1880, 24, 398; *Glaser's Annalen*, 1880, 7, 476; *Stahl u. Eisen*, 1882, 2, 423; *Verh. Ver. Bef. Gewerbeft.*, 1882, 233.

⁴ H. Wedding, *J. Iron Steel Inst.*, 1885, i. 187; *Stahl u. Eisen*, 1886, 6, 633.

⁵ S. Stein, *Stahl u. Eisen*, 1888, 8, 595.

arrangement of iron and steel crystals in ingots had been determined macroscopically as early as 1868,¹ and the extension of this knowledge to the microscopic structure was followed by very numerous investigations in this direction.

THE STUDY OF ALLOYS

The further progress of metallography is intimately connected with the study of the nature of metallic alloys. The word *alloy*, or its equivalent form *allay*, was originally used to signify an intimate association of two or more metals and is so employed by Chaucer. Its special and restricted use to denote the base metal added to gold or silver for the purpose of working or coining, is of later origin, and is etymologically incorrect. The present use of the word is in accordance with its original signification.

It was long a matter of controversy whether alloys were to be regarded as chemical compounds or as mechanical mixtures. Perhaps the earliest researches directed towards the immediate solution of the problem are those of Levol,² who by the systematic examination of series of alloys of progressively changing composition, was able to show that only a few alloys remain homogeneous throughout the process of crystallization, all others being capable of separation into more fusible and less fusible parts. A few alloys proved to be exceptions to this rule, having a constant melting-point, and retaining the same composition throughout the processes of freezing and melting. In the alloys of silver and copper, a mixture in the proportions represented by the formula Ag_3Cu_2 was found to have this property, and was considered by Levol to be a definite compound. We now know that this is incorrect, and that Levol's alloy is the eutectic mixture of the two metals, which do not form an inter-metallic compound. Nevertheless, the research marks a distinct advance in the knowledge of alloys.

The view that alloys are to be regarded as solidified

¹ D. Tschernoff, *Mém. Soc. techn. Russ.*, April, 1868.

² A. Levol, *J. Pharm. Chim.*, 1850, [iii.] 17, 111; *Ann. Chim. Phys.*, 1852, [iii.] 36, 193; 1853, [iii.] 39, 163.

solutions, which may or may not contain compounds according to circumstances, is due to Matthiessen.¹ The method of investigation which he adopted was the study of physical properties, such as density, electrical conductivity, and thermo-electric power, comparing together alloys containing varying quantities of the same component metals, and seeking for any discontinuous changes of properties which might mark the presence of compounds. The work of Matthiessen was the starting-point of the application of physical chemistry to the study of alloys. It was followed by many similar determinations of conductivity, etc.²

After the discovery of Raoult's law of the depression of freezing-point of solutions, the study of alloys from this point of view was suggested by the fact that alloys very frequently melt at a lower temperature than their components. In the same year, the depression of the vapour-pressure of mercury produced by the addition of other metals was studied by Ramsay,³ and the depression of the freezing-point by Tammann,⁴ and by Heycock and Neville.⁵ Complete curves, showing the change of freezing-point on passing from one end to the other of a series of binary alloys, were published for a number of pairs of metals by Kapp⁶ and Heycock and Neville.⁷

The application of the theory of phases of Gibbs⁸ to alloys was suggested by Jüptner⁹ and by Le Chatelier.¹⁰ Its first

¹ A. Matthiessen, *Brit. Assoc. Rep.*, 1863, 37; *Trans. Chem. Soc.*, 1867, 20, 201. Later references are given in Chapter XII.

² G. Kamensky, *Proc. Phys. Soc.*, 1883, 6, 53; *Phil. Mag.*, 1884, [v.] 17, 270; V. Strouhal and C. Barus, *Abh. k. böhm. Ges. Wiss.*, 1884, [vi.] 12, No. 14; C. Barus, *Amer. J. Sci.*, 1888, [iii.] 36, 427. See Chapter XII.

³ W. Ramsay, *Trans. Chem. Soc.*, 1889, 55, 521.

⁴ G. Tammann, *Zeitsch. physikal. Chem.*, 1889, 3, 441.

⁵ C. T. Heycock and F. H. Neville, *Trans. Chem. Soc.*, 1889, 55, 666.

⁶ A. Kapp, *Ann. Physik.*, 1901, [iv.] 6, 754.

⁷ *Phil. Trans.*, 1897, 189A, 25.

⁸ See *The Phase Rule*, by Dr. A. Findlay, in this series.

⁹ H. von Jüptner von Jonstorff, *Stahl u. Eisen*, 1899, 19, 23.

¹⁰ H. Le Chatelier, *Compt. rend.*, 1900, 130, 85.

important application was made by Roozeboom¹ in a famous paper, in which the results obtained in the thermal examination of iron and steel by Roberts-Austen² were utilized in the construction of a complete diagram of the thermal equilibrium of iron and carbon. This diagram has formed the basis of all the subsequent discussions of the iron-carbon system, and although it has been found necessary to modify it in a number of particulars, its general outline has been preserved in all the schemes proposed by later workers. Roozeboom adopted the hypothesis of the existence of three allotropic modifications of iron, stable within different ranges of temperature, originally propounded by Osmond,³ and this hypothesis has been generally accepted as the best expression of the known facts, in spite of strong opposition from a school of metallurgists who attribute the phenomena usually considered as being due to allotropy solely to the influence of the dissolved carbon.⁴

The possible types of solid solutions or mixed crystals in binary systems had been reviewed from the theoretical standpoint of the phase rule by Roozeboom in 1899.⁵ The first important application of his teaching to alloys other than those of iron was made by Heycock and Neville in their study of the copper-tin alloys, in which the method of quenching from determined temperatures was introduced as a method of research.⁶ The same paper also contains photo-micrographs which represent the highest degree of accuracy and technical perfection then attained. The application of microscopical methods to alloys other than those of iron was at first confined to a few alloys, such as

¹ H. Bakhuis Roozeboom, *Zeitsch. physikal. Chem.*, 1900, **34**, 437; *J. Iron Steel Inst.*, 1900, ii, 311.

² W. C. Roberts-Austen, 5th Rep. to Alloys Research Committee, *Proc. Inst. Mech. Eng.*, 1899, 35.

³ F. Osmond, *Mém. Artill. Marine*, 1887, **15**, 573; *J. Iron Steel Inst.*, 1890, i, 38; *Compt. rend.*, 1890, **110**, 242, 346.

⁴ J. O. Arnold, *J. Iron Steel Inst.*, 1894, i, 107; R. A. Hadfield, *ibid.*, 156, and later papers by these writers.

⁵ *Zeitsch. physikal. Chem.*, 1899, **30**, 385, 413.

⁶ *Phil. Trans.*, 1902, **202A**, 1. This method had been employed in the study of steels by H. M. Howe in 1893, *Trans. Amer. Inst. Min. Eng.*, **23**, 466.

the brasses and the alloys of gold,¹ but its subsequent development has been very rapid. In 1901 a number of memoirs dealing with the structure and constitution of alloys, most of which had previously appeared in the *Bulletin de la Société d'Encouragement*, were collected in a volume which has had a great influence in extending the knowledge of metallographic methods and results.² In this country, the Alloys Research Committee, under the guidance of Roberts-Austen, conducted experiments the results of which were embodied in an important series of reports commencing in 1891.³ The work of the committee was transferred to the National Physical Laboratory in 1904, and is still continued.⁴ The school of metallographists founded in Paris by Osmond and Le Chatelier has also contributed very largely to the advancement of the study.

In the year 1903 a memoir by Tammann appeared,⁵ in which the investigation of the thermal behaviour of alloys was shown to be capable of yielding very full information as to the nature of the equilibrium of the components. Since that date a large number of memoirs have been issued from the Göttingen laboratory, and the number of binary systems investigated has been multiplied several times in the last few years. A few ternary systems have also been examined. Unfortunately, the small quantities of material used, and the insensitiveness of the experimental method adopted, have given rise to objections, and it is only possible to regard some of the diagrams obtained

¹ G. Guillemin, *Compt. rend.*, 1892, 115, 232; G. Charpy, *ibid.*, 1893, 116, 1131; 1895, 121, 494; 1896, 122, 670; F. Osmond and W. C. Roberts-Austen, *Phil. Trans.*, 1896, 187A, 417; J. O. Arnold and J. Jefferson, *Engineering*, 1896, 61, 176; T. Andrews, *ibid.*, 1898, 66, 411, 541, 733; 1899, 67, 87; H. Le Chatelier, *Bull. Soc. d'Encourag.*, 1896, [v.] 1, 559; J. E. Stead, *J. Soc. Chem. Ind.*, 1897, 16, 200, 506; 1898, 17, 1111; H. Behrens, *Das mikroskopische Gefüge der Metalle u. Legierungen*, Leipzig, 1894.

² *Contribution à l'Étude des Alliages*, Paris, 1901.

³ *Proc. Inst. Mech. Eng.*, 1891, 543; 1893, 102; 1895, 238; 1897, 31; 1899, 35; 1901, 1211 (W. Campbell); 1904, 7 (W. Gowland).

⁴ See H. C. H. Carpenter, R. A. Hadfield, and P. Longmuir, *Proc. Inst. Mech. Eng.*, 1905, 857; H. C. H. Carpenter and C. A. Edwards, *ibid.*, 1907, 57; W. Rosenhain and F. C. H. Lantsberry, *ibid.*, 1910, 119; W. Rosenhain and S. L. Archbutt, *ibid.*, 1912, 319.

⁵ *Zeitsch. anorg. Chem.*, 1903, 37, 303.

as first approximations. The same method has been applied, but with increased experimental precautions, by Friedrich,¹ Kurnakoff,² and also by American and Italian workers.³

The further progress of metallography will be dealt with in greater detail in the chapters allotted to its respective departments. Its growth has been so rapid as to require special organs to serve for the collection and comparison of the results obtained by workers in different countries. The *Metallographist*, established in America as an international medium in 1898, continued to serve this purpose until 1903, when it became merged in a publication devoted to the iron and steel industries. In the year 1904 two new periodicals appeared simultaneously in France and Germany, namely, *La Revue de Métallurgie* (monthly) and *Metallurgie* (fortnightly), the former chiefly representing the school of Le Chatelier, and the latter those of Wüst and Friedrich, both also providing a *résumé* of metallographic work published elsewhere. The work of the Göttingen school, and much of that conducted by the Russian investigators, appears in the *Zeitschrift für anorganische Chemie*, and that of Bancroft, Shepherd, and others in the *Journal of Physical Chemistry*, whilst the Iron and Steel Institute (founded 1869), the Faraday Society (founded 1903), and the Institute of Metals (founded 1908) also embrace metallography in their scope. The literature of the science is, however, dispersed through a large number of publications dealing with chemistry, metallurgy, and engineering. The appearance, since February, 1911, of a central organ, the *Internationale Zeitschrift für Metallographie*, has proved of great advantage to the science.

The fact that metallographic researches have resulted as yet in comparatively few far-reaching generalizations is to a large extent due to the wide range of the systems to be investigated. The number of metals, excluding those which

¹ K. Friedrich, *Metallurgie*, 1905, **2**, No. 22, and later papers.

² N. S. Kurnakoff, *Zeitsch. anorg. Chem.*, 1900, **23**, 439. The first publication of this and subsequent memoirs is in the *J. Russ. Phys. Chem. Soc.* (in Russian).

³ W. D. Bancroft, *J. Physical Chem.*, 1899, **3**, 217; E. S. Shepherd, *ibid.*, 1902, **6**, 519, etc., G. Bruni, G. Sandonnini and E. Quercigh, *Zeitsch. anorg. Chem.*, 1910, **68**, 73, etc.

are only obtainable in the laboratory with difficulty, cannot be put at less than 30, and increases with each advance in the knowledge of the rarer elements. The number of binary systems which can be formed from these 30 metals is 435, and when we consider that many of the systems are of a high degree of complexity, owing to the presence of inter-metallic compounds, solid solutions and allotropic modifications, it is evident that the field is one which has hitherto been very incompletely surveyed. The possible ternary systems composed of the same metals number 4060, of which only some half-dozen have been examined, whilst the innumerable equilibria of a higher order remain untouched. It is not essential that all of these possible systems should be investigated, but the types of equilibrium which present themselves are so numerous that it is unsafe to generalize as to the behaviour of alloys except as the result of examining a very large mass of experimental material. The requirements of technical practice justify a very minute investigation of the more important systems under diverse physical and mechanical conditions. Fortunately for the science, the steels, bronzes, brasses, and other alloys of technical importance are also among the most interesting from a physico-chemical point of view, and the mutual reaction of science and industry has in this respect had the most beneficial results.

Two methods of investigation, the thermal and the microscopical, are of primary importance in the study of metallography. When suitably applied and combined, they are capable of revealing the principal facts concerning the equilibrium of the components. All other methods, although valuable in themselves, and sometimes indispensable, must be regarded as subsidiary to these two in the range of their applicability. The thermal and microscopical methods will therefore be discussed in detail, a shorter account being given of the investigations dealing with the physical properties, such as density, electrical conductivity, and electrolytic potential, and with the chemical action of reagents on alloys. It will then be shown how the experimental results are combined in the construction of an equilibrium diagram, and how they may

be made to furnish information as to the molecular condition of the component metals. The behaviour of alloys under mechanical stress producing deformation is another important department of metallography, with a history of its own. Lastly, short accounts of the metallography of the most important technical alloys will be given as concrete illustrations of the methods described. An appendix contains a list, with references to the literature and brief indications of the character of the system, of all those binary and ternary systems of which published descriptions have been found.¹

¹ Critical descriptions of the systems investigated, with the equilibrium diagrams, are provided by W. Guertler, *Metallographie*, Berlin, 1909, and K. Bornemann, *Die binären Metallegierungen*, Halle, 1909, both in course of publication.

CHAPTER II

THE DIAGRAM OF THERMAL EQUILIBRIUM

OF the methods of metallographic investigation enumerated in Chapter I., that which is known as thermal analysis must be regarded as the foundation of all the others. It is rarely possible to interpret correctly the results of microscopical or other investigations without some knowledge of the diagram of thermal equilibrium, which shows what phases may be expected to be present in an alloy of given composition under given conditions of cooling. In the great majority of cases, however, it requires to be supplemented by microscopical examination, whilst the magnetic, electrical, and other methods of study to be described later all find application in special cases, and indeed are sometimes indispensable. But the fundamental importance of the thermal method demands for it the first place in a work on metallography.

The basis of the diagram of thermal equilibrium is the freezing-point curve, the co-ordinates of a point on which are the composition of the alloy and the temperature at which crystallization begins when the fused alloy is cooled. In the older metallographic investigations, this was the only curve determined,¹ and this is still the case with much work published at the present day, especially in France. But the work of Roozeboom² has shown that the complete thermal diagram comprises not only the freezing-point curve, or "liquidus," but

¹ See, for example, H. Gautier, *Bull. Soc. d'Encouragement*, 1896, [v.] 1, 1293; C. T. Heycock and F. H. Neville, *Phil. Trans.*, 1897, 189A, 25; *Trans. Chem. Soc.*, 1897, 71, 383.

² *Zeitsch. physikal. Chem.*, 1899, 30, 385, 412.

also curves representing the composition of the solid separating from the fused alloy, and the transformations, if any, undergone by the constituents after solidification. It is in fact a graphical representation of the dependence of the number and nature of the phases possible to the system when in equilibrium on the composition and temperature.

When a body, such as a crucible containing an alloy, is cooling by radiation without undergoing any change of state, the curve connecting its temperature with the time has a regular form, being logarithmic when the surroundings are at a constant temperature, and rectilinear when the temperature of the environment is progressively and regularly lowered.¹ But this regularity disappears when the cooling involves a change of state, as in the freezing of a liquid. The continuous passage from the liquid to the glassy or amorphous state, which characterizes many silicates and also such substances as sealing-wax, is not met with in alloys, which invariably exhibit a discontinuity of properties at a definite temperature, the freezing-point. In all cases hitherto observed, the passage from the liquid to the solid state is accompanied by the development of heat, although the existence of a negative heat of fusion is sometimes held² to be theoretically possible. The first particles of solid which separate from the solution therefore liberate a certain quantity of heat. Any further loss of heat by radiation, instead of reducing the temperature of the mass, causes a further separation of solid, and this process continues, the temperature remaining constant, until the whole of the substance has passed from the liquid to the solid state, after which the temperature again falls in a regular manner. If we represent the fall in temperature of a substance cooling without change of state by the curve A in Fig. 1, the curve of a pure substance, freezing at constant temperature, will have the form shown at B (Fig. 2). This is an ideal curve, and owing to undercooling, to the inequality of temperature throughout the mass, and to other causes, the observed curves

¹ W. Plato, *Zeitsch. physikal. Chem.*, 1906, 55, 721. See Chapter VI.

² G. Tammann, *Krystallisieren und Schmelzen* (Leipzig, 1903), 35. The possibility is, however, disputed by Roozeboom.

deviate more or less from the form represented. The nature of these deviations, and the means of deriving the ideal curve from the observations, will be discussed in Chapter VI. Neglecting these, and assuming ideal conditions, we have a discontinuous curve, the part ab representing the cooling of the fluid metal, the horizontal part bc the process of solidification, and the curve cd the cooling of the solid metal. The portion cd has a steeper slope than ab , as the specific heat is greater in the liquid than in the solid state.

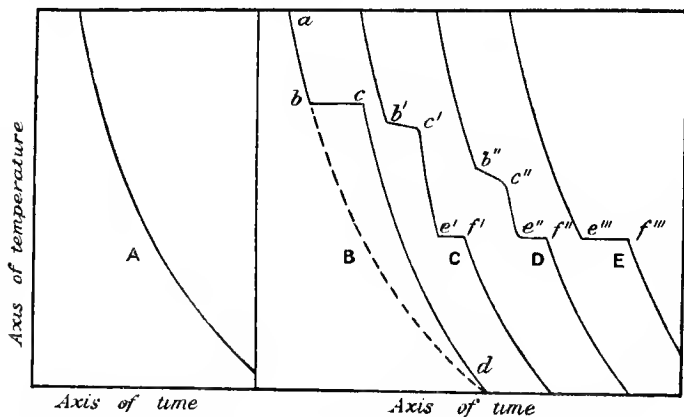

FIG. 1.—Cooling curve without change of state.

FIG. 2.—Cooling curves with change of state.

But if, instead of a pure metal, the crucible contains an alloy of two metals, the process of solidification follows a different course. We will assume, as the simplest case, that the two metals are perfectly miscible in the molten state, forming a homogeneous solution, and that each of them crystallizes in a pure state, uncontaminated by the other, and we will assume further that the quantity of the second metal, N , is small compared with that of the first, M . On cooling to a certain temperature, crystals of M separate from the solution. This temperature is not the freezing-point of the pure metal M , but a somewhat lower one, as the freezing-point of a

substance under the conditions we have assumed is lowered by the addition of a second substance. We have now to see in what way this lowering proceeds, as the quantity of the second substance is progressively increased. In Fig. 3, the vertical axis is that of temperature, the horizontal axis represents the composition of successive mixtures. It is usual to express this composition as a percentage. We then represent the proportion of the second metal present by figures from 0 to 100. At the origin of the axes we have the pure metal M; we therefore say that the *concentration* of the metal N at that point is zero. At the right-hand limit of the diagram we have the pure metal N, the concentration of which is then 100 per cent. It is often convenient, especially when dealing with the theoretical interpretation of the diagram, to express the composition of the alloy in terms of atoms or molecules. In that case, the points on the axis of abscissæ represent the atomic or molecular concentration, that is, the number of atoms or molecules of the second metal present in 100 atoms or molecules of the mixture. Atomic concentrations will be generally employed in the sequel. The concentration of M is of course found in all cases by subtracting that of N from 100.

Neglecting for the present the remainder of the cooling curve, and considering only the temperature at which crystallization commences, the effect of the addition of a small quantity of the metal N is to depress this temperature from m (the freezing-point of pure M) to m' (Fig. 3). Further successive small additions of N lower the initial temperature of crystallization still more, for example, to m'' and m''' . In exactly the same way, if n be the freezing-point of the pure metal N, successive small additions of M lower the temperature at which solidification begins successively to n' , n'' , and n''' . If in Fig. 3, therefore, the abscissæ are taken to represent the proportions of M and N in the fluid mixtures and the ordinates the temperatures at which the first particles of solid separate on cooling, these temperatures lie on two curves (represented for the sake of simplicity as straight lines) sloping downwards from m and n respectively. A point, e , must consequently exist at which these two curves intersect. The alloy corresponding

with the composition c , found by dropping a perpendicular from e upon the concentration axis, has the lowest initial freezing-point of the whole series. It is hence known as the *eutectic alloy* (Greek $\epsilon\upsilon\tau\eta\kappa\tau\omicron\varsigma$, easily-melting, from $\epsilon\upsilon + \tau\eta\kappa\text{-}\epsilon\iota\nu$) or simply *eutectic*, and the point e is called the *eutectic point*, the introduction of these convenient terms being due to Guthrie.

Returning now to the cooling curves of individual alloys, represented in Fig. 2, the point at which the curve changes its direction, owing to the development of heat on solidification, is lowered by the addition of the second metal from m to m' . The portion of the curve which represents the passage from the liquid to the solid state, however, is no longer horizontal, as bc ; that is, the solidification of the mass no longer takes place at constant temperature. For the separation of the first crystals of the metal M alters the composition of the part remaining fluid, which is now richer in N than before. Referring to Fig. 3, it will be seen that the separation of crystals from such a mixture takes place at a temperature lower than m' . Consequently, as the metal M is withdrawn from the molten alloy by crystallization, the mother-liquor becomes progressively richer in N, and the temperature at which it can deposit more crystals progressively sinks. This gives to the part $b'c'$ of the cooling curve C (Fig. 2) the sloping form indicated. For alloys containing more and more of the second metal N, the slope of the cooling curve becomes steeper and steeper, as in D. The change in direction at the point b'' or b''' being much less than at b , the temperature of initial solidification becomes more difficult to determine as the proportion of N in the alloys increases.

In all these cases, as M is withdrawn from the molten mass, a point must be reached at which the mother-liquor has the composition and temperature represented by the eutectic point e . In order to determine what happens at this point, it will be convenient to consider the freezing-point curve (Fig. 3) from a somewhat different standpoint. The left-hand branch of the curve, me , may be considered as a solubility curve, since it represents the temperatures at which solutions of M in N

become saturated with respect to M. In like manner, the right-hand branch represents the temperatures at which solutions of N in M (for in alloys either metal may be regarded in turn as solvent or as solute) become saturated with respect to N. Now, at the eutectic point e , being the point of intersection of the two solubility curves, the solution is simultaneously saturated with M and N. Should crystals of M separate, it at once becomes supersaturated with respect to N, and equilibrium can only be restored by the separation of crystals of N. The metals M and N therefore crystallize

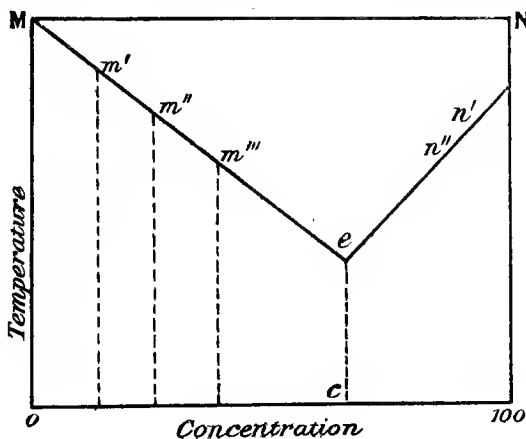

FIG. 3.

together, the temperature remaining constant until the whole of the mass has solidified. This constancy of freezing-point is characteristic of eutectic mixtures.

In an alloy with the initial freezing-point m' , containing only a small quantity of the metal N, the greater part will have solidified before the eutectic point is reached. The amount which will solidify at the eutectic temperature is therefore very small, and will be represented by a very short horizontal portion of the cooling curve, as at $e'f'$ in the curve C (Fig. 2). As alloys richer in N are examined, this horizontal portion becomes more strongly marked, as in D. Finally, an

alloy having exactly the eutectic composition solidifies completely at constant temperature, so that its cooling curve has the form E. When the proportion of N in the alloys is further increased, so that the crystals which separate first are those of the metal N, the length of the eutectic horizontal again decreases, becoming less and less as the composition of the alloy approaches the pure metal N.

We are now in a position to construct the complete diagram of thermal equilibrium for alloys of M and N. The time taken for the eutectic mother-liquor to solidify, that is, the length of the lower horizontal portion of the cooling curve, may be considered as proportional to the quantity of eutectic present, the conditions of cooling of all the alloys being assumed to be identical. These "eutectic times" may be plotted as ordinates against the composition of the alloys as abscissæ, as in the lower part of Fig. 4. The intersection of the two branches gives the eutectic composition, since it indicates the maximum time of eutectic solidification. When the two branches of the freezing-point curve are strongly curved instead of being, as we have represented them, straight lines, it may be difficult to fix their exact point of intersection, and the plotting of the eutectic times then becomes a valuable auxiliary in fixing the position of the eutectic point. We owe this use of time-composition curves, which finds much wider application in the more complex cases to be considered later, to Tammann.¹

The exact position of the two branches of the freezing-point curve now having been determined, the remainder of the diagram may be constructed. Since the cooling curves of all mixtures of M and N show an arrest at a constant temperature, the eutectic temperature, a line may be drawn across the diagram from C to D (Fig. 4, upper part) through the eutectic point E, and parallel with the axis of concentration. This line represents the solidification of the eutectic mother-liquor, and is called the *eutectic horizontal*. A vertical line from E to F separates those alloys which contain an excess of the metal M over the eutectic proportion from those which contain an excess of N.

¹ *Zeitsch. anorg. Chem.*, 1903, **37**, 303; 1905, **45**, 24; 1905, **47**, 289.

Assuming that the alloys are not heated to so high a temperature as to produce an appreciable amount of metallic vapour, any alloy the temperature and composition of which is represented by a point lying above the freezing-point curve AEB is in a liquid state. Points on AE or EB represent the com-

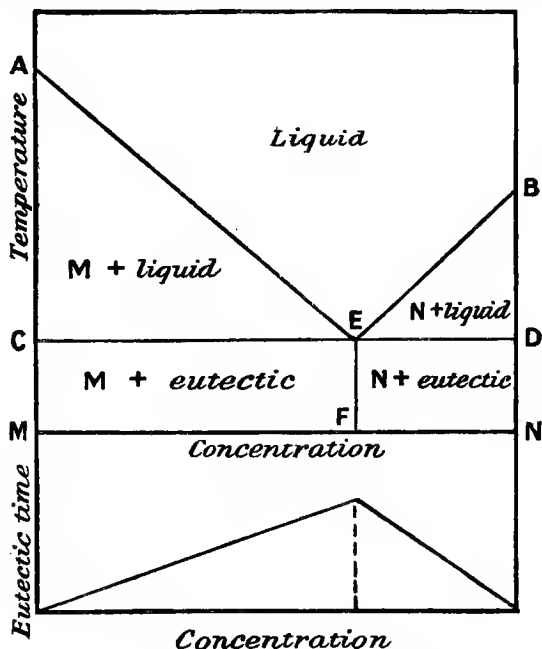

FIG. 4.—Thermal analysis, simplest case.

mencement of crystallization of the metals M and N respectively. An alloy represented by a point within the triangle ACE consists of crystals of M, together with a still liquid mother-liquor. In the same way the triangle BDE encloses mixtures of N with mother-liquor. All alloys below the line CD are solid. If to the left of the line EF, they consist of crystals of M together with eutectic; if to the right, of crystals of N + eutectic.

THE FORM OF THE FREEZING-POINT CURVE

In the simplest case, the lowering of the freezing-point of a metal by the addition of a second metal is proportional to the number of molecules of the latter added. This is the well-known law of Raoult, which may be expressed by saying that on the addition of one molecule of N to 100 molecules of M the freezing-point is depressed by an amount independent of the nature of the added metal, and known as the *molecular depression*. Two assumptions are here made, as in the earlier part of this chapter, namely, (1) that the two metals do not form a compound under the conditions of the experiment, and (2) that the metal M crystallizes from the fluid alloy in a pure state. It will be shown later that the metals are frequently monatomic, but it is best for the present to make no assumption as to their molecular complexity, and therefore to use atoms instead of molecules as the units. The composition of an alloy is then expressed in *atomic percentages*, the abscissæ of the temperature-concentration diagram being the number of atoms of one of the component metals in 100 atoms of the alloy. The atomic percentage may be calculated from the percentage by weight in the following manner:—

If p and $(100 - p)$ are the percentages of the metals M and N respectively, a and b their atomic weights, and x and $(100 - x)$ the atomic percentages in the mixture, then

$$x = \frac{100p}{p + (100 - p)\frac{a}{b}}$$

$$(100 - x) = \frac{100(100 - p)}{p\frac{a}{b} + (100 - p)}$$

Since the calculation of the atomic proportions of each alloy examined is very tedious, it is advisable to make the calculation for three or four percentages only, and then to plot the atomic percentages found against the percentages by weight, to draw a smooth curve through the points, and to find the

composition of the remaining alloys of the series by graphical interpolation.

An important advantage of the use of atomic percentages instead of percentages by weight is that the branches of the freezing-point curve are then straight lines for the range over which the laws of dilute solutions hold good, which is generally the case up to 5 or 10 atomic per cent. The slope of the curve, dx/dt , then represents the depression of freezing-point produced by the addition of one atom of the second metal. This is called by Heycock and Neville the *atomic fall*. The deviations from the rectilinear form of such curves, and the mode of calculation of the molecular complexity of the dissolved metal, will be discussed later, in connection with the study of the exact form of freezing-point curves, and the formulæ which have been employed to represent them.¹ The most conspicuous advantages of the atomic method of plotting, however, will be seen in dealing with inter-metallic compounds.

THE EUTECTIC ALLOY

The fact that with many pairs of metals it is possible to prepare one alloy which has a freezing-point lower than that of any other member of the series has long been known, and was made use of in the preparation of the so-called "fusible metals." The production of a liquid by mixing a solid salt with solid ice in "freezing mixtures" was also well known.² As far back as 1864, Rüdorff³ gave the correct explanation of the production of freezing mixtures, showing that the point of minimum temperature thus obtained was the intersection of the curve of separation of ice from salt solutions with that of the solubility of salt in water. The fact that metals showed a similar behaviour, so that on mixing two solid amalgams a liquid

¹ See Chapter XV.

² For the earlier history of freezing mixtures, see C. G. von Wirkner, *Geschichte und Theorie der Kälteerzeugung*, Hamburg, 1897. The earliest quantitative measurements are those of R. A. F. de Réaumur, *Mém. Acad. Sci.*, 1734.

³ *Pogg. Ann.*, 1864, [v.] 2, 337.

amalgam might be produced with considerable lowering of temperature, in complete analogy with freezing mixtures, had been observed by Döbereiner in 1824.¹

The freezing-points of a very extensive series of salt solutions were investigated from this point of view by Guthrie.² Unfortunately, however, in spite of the work of Rüdorff, mentioned above, and of de Coppet,³ the constancy of composition and freezing-point and the characteristic appearance of the mixture of minimum freezing-point led Guthrie to regard it as a combination of the salt with water, stable only below 0°, to which he gave the name of *cryohydrate*. In his later investigations, the complete resemblance between the behaviour of cooled salt solutions, alloys, and mixtures of fused salts was shown, and the word "eutectic" was introduced.⁴ The view that the cryohydrate was a chemical compound had been combated in the meantime by Pfaundler,⁵ but was long popular. From the fact that cryohydrates always contain a large quantity of water in proportion to that of the salt, it is usually possible to find a formula of a hydrate to represent its composition approximately. In alloys and mixtures of fused salts in which the constituents are present in more nearly equal proportions, the deviation from a simple molecular ratio is often very marked, and the composite nature of eutectics was consequently more readily admitted. Even here the occasional approach of eutectic alloys to simple formulæ led to their being regarded as compounds; and even at the present time the assignment of a formula to the alloy occupying a minimum on the freezing-point curve is not unusual in some published work. A typical case is that of the eutectic alloy of copper and silver, which was long known as Levöl's alloy⁶ and regarded as a compound having the formula Ag_3Cu_2 .

¹ *Schweigg. J.*, 1824, 42, 182.

² F. Guthrie, *Phil. Mag.*, 1875, [iv.] 49, 1, 206, 266; 1876, [v.] 1, 49, 354, 446; 1876, [v.] 2, 211; 1878, [v.] 6, 35, 105.

³ *Bull. Soc. Vaudoise Sci. Nat.*, 1871, [ii.] 11, 1.

⁴ *Phil. Mag.*, 1884, [v.] 17, 462; *Proc. Phys. Soc.*, 1884-5, 6, 124, 169.

⁵ *Ber.*, 1877, 10, 2223; see also Offer, *Sitzungsber. Wien. Akad. Sci.*, 1880, 81, 1058.

⁶ A Levöl, *J. Pharm. Chim.*, 1850, [iii.] 17, 111.

From what has been said above, in discussing the thermal diagram, it will be seen that the eutectic is really a conglomerate of the two components. From the fact that its cooling curve has the same form as that of a pure substance, namely, that of Fig. 2, B, and that the crystallization of both components takes place simultaneously, so causing a very intimate mixture, the mistake of considering it as homogeneous is readily explained. It will be seen later, in treating of the microscopic and other properties of alloys, that the appearance of eutectic alloys is characteristic, and often quite unlike that of mere mechanical mixtures. The heterogeneity of cryohydrates was not definitely proved until 1895, when Ponsot¹ showed by microscopic examination that distinct crystals of ice, and of potassium permanganate, potassium dichromate, and copper sulphate, could be observed in the frozen cryohydrates of those salts. The same thing was shown for the cryohydrates of colourless salts by examination in polarized light. Considering the false idea implied by the term "cryohydrate," it is better to abandon its use, and to employ the term "eutectic" for salt solutions, alloys, mixtures of fused salts or organic substances, and igneous rocks alike.

DISCUSSION OF THE PHASE EQUILIBRIUM

The presentation of metallographic results in the language of the phase-doctrine is so frequent, that it is desirable to discuss the simple case already examined, from this point of view. It is outside the scope of this work to set forth the principles of the phase rule, which have been fully explained in another work of this series.² Here it will be sufficient to take the rule itself for granted, referring elsewhere for its justification.

In all the cases to be considered in metallography, the *components* of the system are the pure metals. The *phases* are

¹ *Bull. Soc. Chim.*, 1895, [iii.] 13, 312.

² *The Phase Rule*, by Dr. A. Findlay. For the theoretical basis on which the rule is founded, see the work by Dr. F. Donnan, on *Thermodynamics*, in the same series.

such homogeneous portions of the system as are separated from each other in space by bounding surfaces. Thus the vapour forms a single phase. There may be one or more liquid phases, for instance, a vessel containing mercury, water, and oil, shows three coexistent liquid phases, separated from one another by definite bounding surfaces. Amongst alloys, the system lead-zinc affords an example of two separate liquid phases. The various types of crystals which may be present in solid alloys also constitute distinct phases. The number of *degrees of freedom* of a system is "the number of the variable factors, temperature, pressure, and concentration of components, which must be arbitrarily fixed in order that the condition of the system may be perfectly defined."¹

The phase rule now states that, if p be the number of phases, n the number of components, and f the number of degrees of freedom, then

$$f = n - p + 2$$

when the system is in equilibrium. Consequently, for a system of a given number of components, the greater the number of phases present, the less is the variability.

A certain simplification may be introduced into most of the cases with which we have to deal in metallography. It is commonly permissible to neglect the vapour phase when constructing the freezing-point diagram, the volatility of most metals at their melting-points being small. Cases in which the vapour phase is important form a separate class. In the same way, the equilibrium may be assumed to be reached under a constant pressure, that of the atmosphere, since the vessels in which the fusion is carried out are either open to the air or communicate with vessels in which the pressure is that of the atmosphere. Pressure may therefore be omitted from the variables to be considered. The influence of pressure on freezing-point, and on the equilibrium of systems of two or more components, is of great scientific interest, but may be neglected in all but exceptional cases when dealing with metallic alloys. In the closely related subject of the formation

¹ Findlay, *Phase Rule*, p. 15.

of igneous rocks, however, this influence becomes a factor of the very highest importance.

The effect of omitting all consideration of the vapour phase and of changes of pressure from the study of alloys is to reduce the number of variables to two, namely, temperature and concentration. The conditions of equilibrium are then represented by the reduced formula

$$f' = n - p + 1$$

and it is in this form that the phase rule is most usefully employed in the consideration of alloys.

Applying this rule to the case represented in Fig. 4, it will be seen that the whole area above the curve AEB represents mixtures of the two components containing only a single phase, the liquid, so that

$$f' = 2 - 1 + 1 = 2$$

the system has, therefore, two degrees of freedom, or is said to be *bivariant*. This means that both temperature and concentration may vary independently, without any alteration of the number of phases. Let the temperature now change so that a point on the curve AE or EB is reached. Solid begins to separate, that is, a new phase appears. There being now two phases, liquid and solid,

$$f' = 2 - 2 + 1 = 1$$

the number of degrees of freedom is reduced to one, and the system is said to be *univariant*. In this case, any change of temperature determines a corresponding change in the composition of the mother-liquor or liquid phase. Cooling the alloy causes a further deposition of the solid phase, which being in this case the pure metal, does not vary in composition, and the part remaining liquid is correspondingly impoverished. For points on the curve AEB, therefore, to every definite temperature corresponds a definite composition, and fixing either temperature or concentration immediately fixes the other variable.

At the eutectic point E, the two solid metals are simultaneously in equilibrium with the liquid. There are thus three

phases present, and the number of degrees of freedom is therefore reduced to zero, or the equilibrium is only possible at a definite temperature and concentration, the eutectic temperature and eutectic concentration. The system is now said to be *invariant*. The two solid phases are deposited in a constant proportion, so that the composition of the mother-liquor, as well as its temperature, remains constant during the whole process of solidification.

It follows from this that the eutectic alloy is not to be regarded as a phase, but as an intimate mechanical mixture of two solid phases, in this case the two component metals. In the diagram, Fig. 4, therefore, the whole of the area CDN_M represents mixtures of the two solid phases, and the line EF does not mark a boundary between distinct phases. From a micrographic point of view, however, it is necessary to make a distinction between the metal which has solidified as primary crystals along the line AE or EB, and that which has solidified, in intimate association with the second metal, at the point E. This is effected by treating the pure metals M and N and the eutectic alloy as three separate *micrographic constituents*, although the former are single phases, and the latter a conglomerate of two phases. The area CEFM then represents mixtures of primary crystals of M with the eutectic, and EDNF mixtures of primary crystals of N with the eutectic, and this distribution of phases is indicated in the diagram.

The relative proportions of the several phases present in any alloy of any given composition at a given temperature are readily determined from the diagram. In Fig. 5, the upper part of Fig. 4 is repeated. The point *g* represents an alloy of which a part is still liquid, the remainder having solidified in the form of crystals of the pure metal M. It is required to find the proportion of solid in the mixture, and the composition of the still liquid portion. A horizontal line drawn through *g* cuts the freezing-point curve EB at *r*, and the vertical axis at S. The solid phase being, by hypothesis, the pure metal, its composition is represented by S. The composition of the liquid phase is given by the point *r*, from which the percentage of the metal M in the liquid is found by dropping a perpendicular

on to the concentration axis at x . The alloy represented by the point g therefore consists of crystals of the metal M and a liquid portion which contains Mx per cent. of N and Nx per cent. of M.

If the temperature and concentration of the original liquid alloy were represented at a particular moment by the point o , then on cooling, the curve AE is cut at the point p . At this temperature, the composition of the liquid phase is unchanged. As crystals of M separate, however,

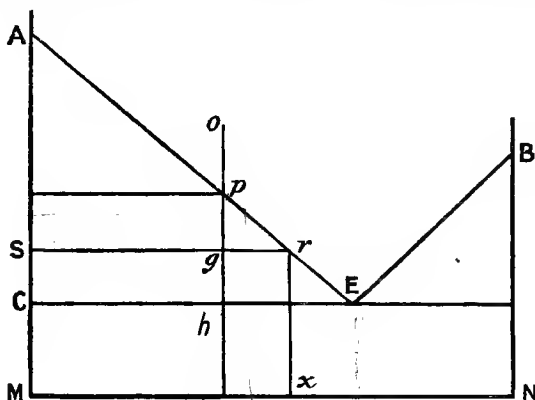

FIG. 5.

the point representing the concentration of the two metals in the liquid phase moves along the line AE from p to r . A simple geometrical consideration shows that the solid and liquid phases are now respectively present in the ratio of gr to Sg . Since the liquid phase must ultimately reach the eutectic concentration, represented by the point E, the relative proportions of solid and liquid respectively on reaching the eutectic temperature are given by the ratio $hE : Ch$. Since the eutectic solidifies as a distinct micrographic constituent, it is convenient for many purposes to express the composition of the completely solidified alloy in terms of the percentage of crystals of the free metal M or N and of the eutectic. For this purpose, a simple graphical method introduced by

Sauveur¹ is very convenient. The vertical axis (Fig. 6) is divided into 100 parts, and the horizontal axis represents the percentage of the two metals in the alloy. The eutectic composition being as before E, straight lines are drawn from M to E and from E to N. An alloy of the composition x , that is, containing Mx per cent. of the metal N and Nx per cent. of M, will in the solid state be made up of xy per cent. of

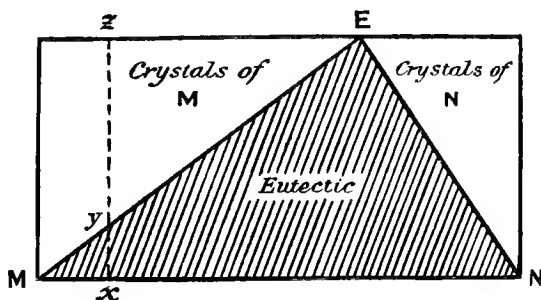

FIG. 6.—Micrographic constituents of a simple binary system.

eutectic and yz per cent. of crystals of M. This form of graphical construction will be frequently employed.

THE MELTING-POINT

We may now consider what happens when a solid alloy of this type is heated. If the alloy has exactly the eutectic composition, the whole of it will liquefy at the eutectic temperature, although this is much below the melting-point of either of the component metals. If, on the other hand, it consists of a mixture of crystals of one of the metals with the eutectic, liquefaction of the eutectic portion only will take place at this temperature. The temperature will then rise, the now fluid eutectic acting as a solvent for the solid crystals, and the composition of the liquid changing in a manner which may be represented by a point travelling upwards along the solubility curve, until the last crystals are dissolved at a temperature

¹ *Metallographist*, 1898, 1, 27.

which is the same as that at which crystallization first began on cooling. The course of events on melting is in fact the reverse of that on freezing, and the heating curve is the reverse of the cooling curve, if we suppose the rate of influx of heat to be sufficient to maintain equilibrium throughout the process. In practice, however, it is far more difficult to ensure equilibrium during melting than during freezing, and heating curves are therefore rarely employed at the melting-point except as an occasional mode of controlling cooling curves.

Since the eutectic alloy is only a conglomerate of two phases, it would seem that a sufficiently intimate mixture of the two metals should melt at the eutectic temperature, and such is found to be the case. With mixtures of coarse particles, such as filings, the contact is not sufficiently intimate, and melting does not take place to an appreciable extent until a somewhat higher temperature has been reached. This point has been investigated experimentally in the case of mixtures of lead and tin.¹ The eutectic alloy of this series melts at 180° , and a mixture of the finely powdered metals, the particles of which did not exceed 0.15 mm. in diameter, melted exactly at that temperature when slowly and regularly heated. When, however, the particles varied in diameter from 0.15 to 0.52 mm., the melting-point rose to 183° , and coarser particles required a still higher temperature to produce fusion. A similar phenomenon, of some practical importance, occurs in the case of grey cast iron.² The graphite, which is one of the constituents of the eutectic, collects together during solidification in the form of comparatively coarse plates. These plates are only slowly dissolved on heating by the metal in immediate contact with them, with the result that the melting-point may be as much as 70° higher than the freezing-point.

Compression of the particles will evidently increase the intimacy of contact, and a compressed mixture of metals is therefore more likely to melt at the eutectic temperature than one mixed by stirring or shaking only. The fact that fusible metals, such as Wood's and Rose's alloys, which melt in hot

¹ C. Benedicks and R. Arpi, *Metallurgie*, 1907, 4, 416.

² P. Goerens, *ibid.*, 137.

water, can be formed by subjecting their components to a pressure of 7500 atm.,¹ does not prove, as was at first supposed, that a reaction occurs between the metals in the solid state, as the result may be explained as being due to the bringing of the particles into such close contact by pressure that equilibrium is readily attained on heating to the eutectic temperature.

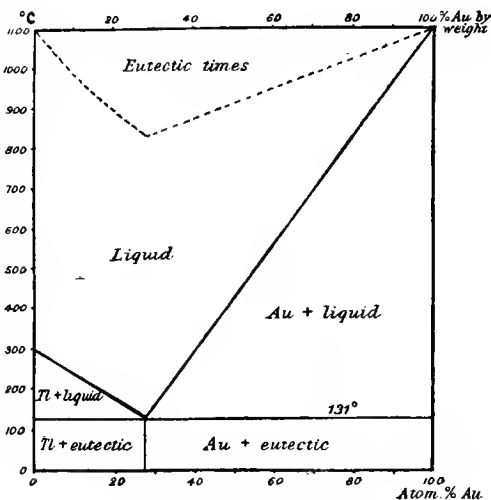

FIG. 7.—Thallium and gold.

Two typical diagrams for eutectiferous series of alloys are shown in Figs. 7 and 8. Fig. 7 represents the alloys of gold and thallium² which do not form either mixed crystals or compounds. The two branches of the curve are very nearly straight lines, indicating a very simple constitution of the solution: The duration of the eutectic arrest on the cooling curves is plotted at the top of the diagram in an inverted form for convenience, and it will be seen that the eutectic composition is sharply determined by its means.

¹ W. Spring, *Ber.*, 1882, 15, 595.

² M. Levin, *Zeitsch. anorg. Chem.*, 1905, 45, 31

The second example is that of the alloys of silver and lead, the equilibrium diagram of which is represented in Fig. 8.¹ The form of the freezing-point curve in this case is of great practical importance, since on it depends the well-known Pattinson process for the desilverization of lead. The eutectic point lies, as will be seen from the diagram, very near to the lead end of the curve, the eutectic alloy containing only 4 atomic per cent. of silver, or 2.25 per cent. by weight. The

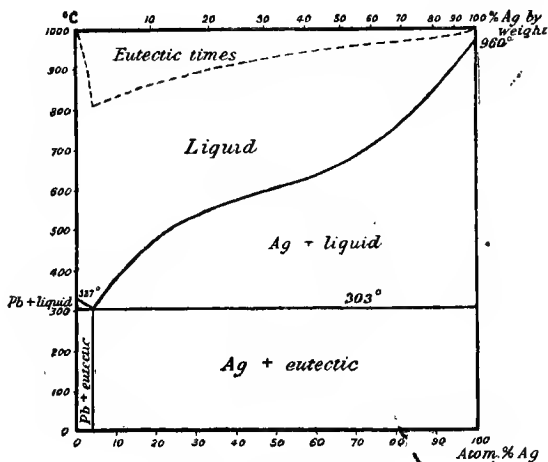

FIG. 8.—Lead and silver.

silver branch of the curve is far from being straight, and has a point of inflection, the appearance is therefore different from that of the gold-thallium diagram, but the arrangement of the fields of phase-equilibrium is nevertheless the same. It is not certain whether the eutectic horizontal reaches exactly to the limits of the diagram, as assumed, but microscopical examination

¹ The upper branches of the curve were determined very accurately by Heycock and Neville (*Phil. Trans.*, 1897, 189A, 25). The complete diagram is drawn from the observations of K. Friedrich (*Metallurgie*, 1906, 3, 396) and G. J. Petrenko (*Zeitsch. anorg. Chem.*, 1907, 53, 200). All three sets of figures are in good agreement.

and the study of the cooling curves indicate that this must be very nearly true.¹

The object of the Pattinson process is the fractional crystallization of an extremely dilute solution of silver in molten lead. The lead, containing 0.009 per cent of silver or more, is cooled until a certain proportion—for instance, seven-eighths—has crystallized, and the crystals are removed by means of a perforated ladle. The portion remaining liquid is then nearer to the eutectic composition than the original alloy, that is to say, it is richer in silver. The crystals collected are those separating on the left-hand branch of the curve in Fig. 8, and consist of practically pure lead. Since, however, a portion of the mother-liquor is always retained mechanically, it is necessary to re-melt the crystals, and to repeat the process. The liquid portions are also again partially frozen, until the final products are almost pure lead, containing at most 0.001 per cent. Ag, and an alloy of the eutectic composition (2.25 per cent. Ag by weight, or 4 atomic per cent.). Since this alloy solidifies at constant temperature, it is evident that the process of fractionation cannot be carried any further.

CASE IN WHICH A COMPOUND OF THE TWO METALS MAY SEPARATE FROM THE MOLTEN ALLOY

The next case to be considered is that in which the two metals can combine together to form a definite compound. The existence of such definite inter-metallic compounds has now been placed beyond doubt, although the exact determination of their formulæ is one of the most troublesome problems of metallography, and all attempts to bring them into line with the conceptions of valency which prevail in chemistry have so far proved unsuccessful.² The properties of alloys are profoundly modified by the presence of such compounds, and the determination of the limits of their existence in each case

¹ The account of the Pattinson process, given in Abegg's *Handbuch der anorganischen Chemie* (vol. ii. part i. p. 668), incorrectly assumes the formation of solid solutions of silver and lead.

² See Chapter XV.

becomes of great importance in the complete metallographic study of any series of alloys.

It is probable that the methods employed in metallography are not capable of detecting all the possible inter-metallic compounds. The reason for this is that experiments with alloys are commonly made under atmospheric pressure, at which many compounds of volatile metals may be more or less completely dissociated at their melting-point, and further that heating to a temperature far above the melting-point may be sometimes necessary to effect combination. As Tammann has remarked, a mixture of liquid oxygen and liquid hydrogen would, if frozen, give no indication of the existence of a compound of the two elements, whereas the result would be very different if the oxygen and hydrogen had been previously heated to such a temperature that water was formed. Metals, which frequently react with one another very sluggishly, may co-exist in a state of false equilibrium, which may be difficult to distinguish from one of true equilibrium. A case of this kind has been met with in alloys of aluminium and antimony.¹ These two metals only combine very slowly when heated together in the liquid state, so that, in a given experiment, only one-tenth of the total mass had combined after heating equivalent proportions at 715° for 100 minutes, three-quarters combining after heating for 30 minutes at 1100° .

In the present chapter, it will be assumed as before that the alloys are throughout in a state of equilibrium, and that the two component metals and the inter-metallic compound separate from the liquid in a pure state, that is, that solid solutions are not formed. Two cases may occur.

A.—THE FREEZING-POINT CURVE SHOWS A MAXIMUM

When the compound formed by the union of the two metals is so stable that it may be heated to its melting-point without decomposition, it behaves similarly to a pure metal, and its freezing-point is depressed by the addition of either of the

¹ G. Tammann, *Zeitsch. anorg. Chem.*, 1905, 48, 53.

components. The freezing-point curve therefore shows a maximum corresponding with the composition of the compound. If the affinity of the one metal for the other be so great that the compound is formed with a large development of heat, this maximum may lie considerably above the freezing-point of either of the component metals. A conspicuous example of this is found in the amalgams of the alkali metals with mercury. Whilst the freezing-points of mercury, sodium, and potassium are respectively— 38.8° , 97.6° , and 62.5° , the compounds NaHg_2 and KHg_2 solidify at 346° and 279° respectively.¹

A compound such as NaHg_2 , occupying a maximum on the freezing-point curve, melts to a liquid of the same composition as the solid. Fusion and solidification therefore take place at a constant temperature, and the cooling curve of the compound is in every respect like that of a pure metal. This being so, alloys containing as solid phases only the compound MN and one of its component metals, for instance M, may be considered as a binary system of the same type as those already discussed, consisting, that is to say, of two branches intersecting in a eutectic point. A second binary system is made up of alloys containing MN and N as solid phases. Two diagrams similar to Fig. 4 might be placed beside one another, the second descending branch starting from the point B. This would, however, give a sharp point to the summit representing the compound, and this is incompatible with equilibrium, the conditions of which demand that the tangent to the curve at such a point shall be horizontal. The flattening of the curve at the summit indicates that the compound is dissociated to some extent into its components in the liquid phase, the flatness of the curve increasing with increasing dissociation.

The form of curve which presents itself in practice is best illustrated by a concrete example. Fig. 9 has been constructed from the results obtained by two different observers

¹ Schüller, *Zeitsch. anorg. Chem.*, 1904, **40**, 385; N. S. Kurnakoff, *ibid.*, 1900, **23**, 439; E. Jänecke, *Zeitsch. physikal. Chem.*, 1907, **58**, 245.

for the alloys of magnesium and tin.¹ It will be seen that the curve rises to a very pronounced maximum at 66.7 atomic per cent. Mg, indicating the formation of a stable compound Mg_2Sn , melting at 783.4° , that is, considerably above the melting-point of either of the component metals. Two eutectic points occur, the solid phases Sn and Mg_2Sn being in equilibrium with the liquid phase at 210° , and the phases Mg_2Sn and Mg similarly at 565° . Since the eutectic arrests, as shown by the

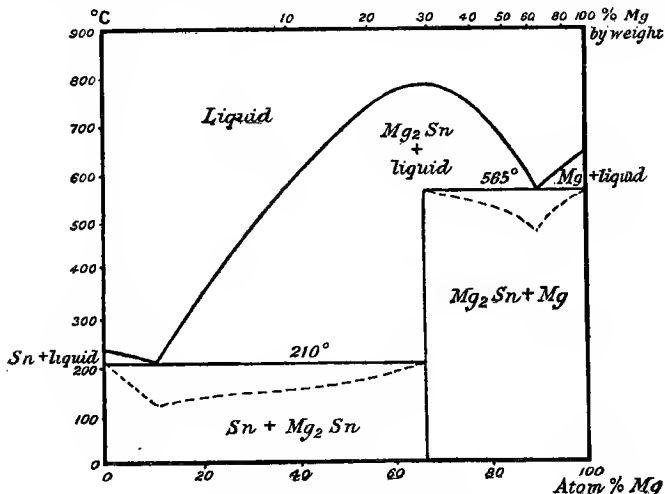
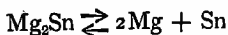

FIG. 9.—Tin and magnesium.

dotted curves, only vanish at the limits of the diagram and at the composition of the compound, it is evident that the conditions assumed in this chapter are fulfilled, namely, that the solid components separate from the liquid in a pure state. The middle branch of the curve is considerably rounded at the summit, indicating that in the fused compound a certain amount of dissociation takes place, represented by the equation—



¹ G. Grube, *Zeitsch. anorg. Chem.*, 1905, 46, 76; N. S. Kurnakoff, *ibid.*, 177.

It will be seen that at all temperatures between 565° and 783° , there exist two liquid alloys with which solid Mg_2Sn can be in equilibrium, the one containing an excess of tin, the other an excess of magnesium. The constituents present in solidified alloys of this series are represented in Fig. 10. On account of the great difference in atomic weight

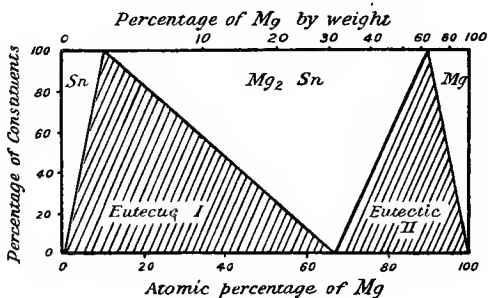
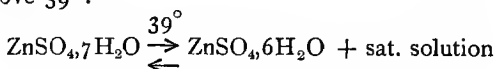

FIG. 10.

between the two metals, the atomic percentages used in plotting differ greatly from the percentages by weight, which are added for comparison above Fig. 10.

B.—THE FREEZING-POINT CURVE SHOWS A BREAK, BUT NO MAXIMUM

Many inter-metallic compounds break up below their melting-point into a liquid alloy and crystals of another compound. This case is comparable with that of many hydrated salts, which dissociate on heating into an aqueous solution and a hydrate containing less water. The heptahydrate of zinc sulphate, $ZnSO_4 \cdot 7H_2O$, for instance, is stable at ordinary temperatures, but if heated to 39° , it decomposes, and at this temperature there is equilibrium between the liquid and vapour phases and two solid phases, namely, the heptahydrate and the hexahydrate, the latter being the stable form above 39° :



There being two components and four phases, the system is invariant, and any increase or decrease of temperature must cause the disappearance of one of the solid phases.

Similar cases are common amongst metallic alloys. The conditions are represented in Fig. 11. The pure metal M separates along the branch AE, the eutectic point being reached at E. The ascending branch EF corresponds with the crystallization of a compound of the two metals M and N, but instead of reaching a maximum and again falling to a second eutectic point, as in the case of the alloys of mag-

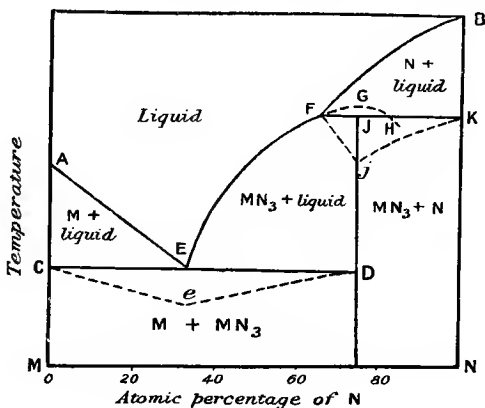
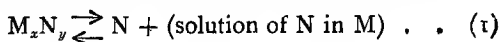

FIG. 11.

nesium and tin, the freezing-point curve changes in direction at the point F, and ascends to the temperature of solidification of the pure metal N at B. The branch BF then corresponds with the crystallization of N from the molten alloys. The break at F is to be interpreted as follows. The compound dissociates at the point F, partly melting to a liquid, and giving up the whole of the metal M contained in it to the liquid, leaving crystals of N. At the temperature represented by F, then, there is equilibrium between two solid and one liquid phase:



Neglecting the vapour phase, we have three phases and two components, or, since $f_1 = n - p + 1$, we have $f_1 = 0$, or the system is invariant, and can only exist at a definite temperature and concentration of the liquid phase.

It now remains to determine the formula of the compound separating along the branch EF. In many of the older determinations, the composition at the point F was taken to be that of the compound. But it is easy to see that this is by no means necessarily the case, although it is one of the possible conditions, and does occasionally occur. The point F is to be regarded as the intersection of two solubility curves, and may frequently lie below the maximum of EF. We may, in imagination, continue the curve EF until it reaches a maximum at G, and regard the curve FGH as that which would be followed by the compound in crystallizing were it not for its dissociation, but such extrapolation is difficult and uncertain. A better means is afforded by the study of the cooling curves. Alloys having a composition between F and the pure metal N will show a development of heat at the temperature F, due to the reaction between a part of the N crystals which have already separated and the still liquid alloy, to form the compound, that is, the reaction represented by the lower arrow in equation (1). The maximum development of heat owing to this reaction coincides with the composition of the compound, as indicated by the arrest curve FjK. Additional evidence is afforded by the form of the curve C ϵ D. The arrest due to the solidification of the eutectic E becomes smaller after the eutectic composition is passed, finally vanishing when the compound is reached at D. In Fig. 11, the curve FjK reaches its maximum, and the curve C ϵ D ends, at 75 atomic per cent. of N, that is, the compound has the formula MN₃.

The amount of each constituent present in the solidified alloys can be determined from Fig. 12. This is, however, an ideal case which presupposes slow cooling, so that complete equilibrium is attained. The reaction at the point F takes place between two solid phases and a solution saturated with respect to both of them—

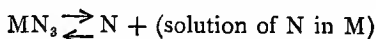

It is therefore likely to remain incomplete, owing to the compound being deposited as an insoluble layer coating the crystals of N and hindering further action. The methods of detecting and allowing for such a condition of incomplete equilibrium will be discussed later, in connection with the practical construction of the thermal diagram, for the present it is sufficient to say that the error is reduced to a minimum by very slow cooling.

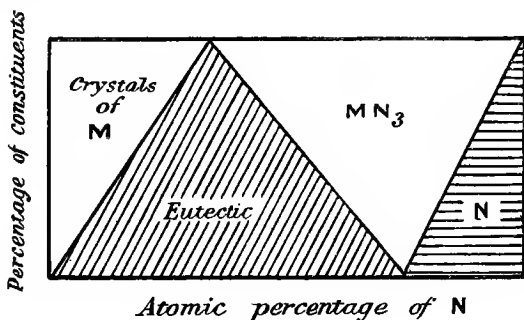
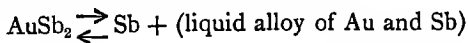

FIG. 12.

In the diagram of the antimony-gold alloys (Fig. 13)¹ it will be seen that the break in the curve coincides with the composition AuSb_2 , and this is therefore one of the exceptional cases referred to above. On cooling liquid alloys containing less than 33.3 atomic per cent. Au, crystals of antimony separate, but on reaching 460° a portion of these reacts with the mother-liquor to form crystals of the compound AuSb_2 . From alloys containing from 33.3 to 65 atomic per cent. Au, this compound constitutes the primary crystallization, and from alloys richer in gold, crystals of gold are the first to separate. Conversely, on heating, the compound melts at 460° , decomposing at the same time into antimony and a liquid alloy, so that F is an invariant point, at which the equilibrium



occurs.

¹ R. Vogel, *Zeitsch. anorg. Chem.*, 1906, 50, 145.

More complicated conditions are very frequent. The freezing-point curve may present several maxima, or several breaks, or both maxima and breaks may occur on the same curve. Examples of this are afforded by the alloys of magnesium and nickel,¹ and of potassium and mercury,² represented in Figs. 14 and 15 respectively. The former system has a

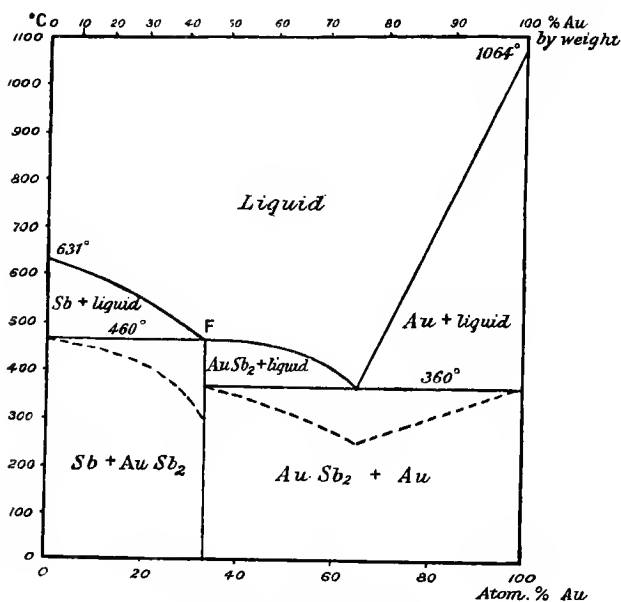

FIG. 13.—Antimony and gold.

well-marked maximum, corresponding with the compound $MgNi_2$, and a break at 770° . Since the transformation at 770° has a maximum duration at 33.3 atomic per cent. Ni, and the eutectic arrest at 512° vanishes at the same concentration, the existence of a compound Mg_2Ni is clearly indicated. The arrangement of phases is obvious from an inspection of the figure.

¹ G. Voss, *Zeitsch. anorg. Chem.*, 1908, 57, 34.

² E. Jänecke, *Zeitsch. physikal. Chem.*, 1907, 58, 245.

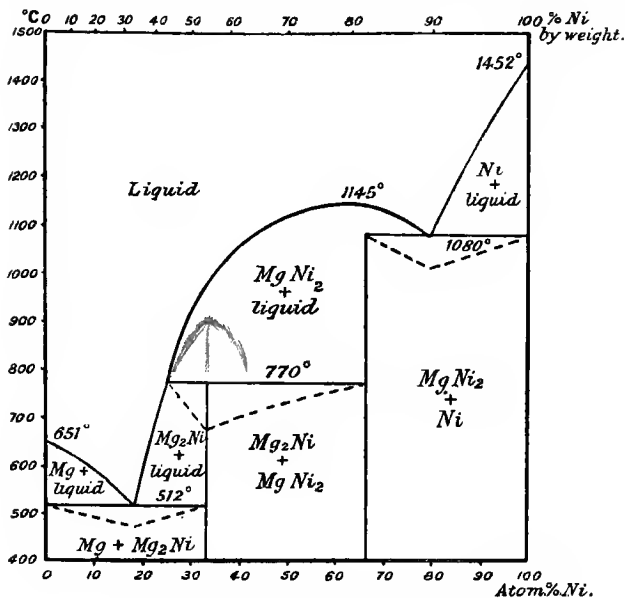

FIG. 14.—Magnesium and nickel.

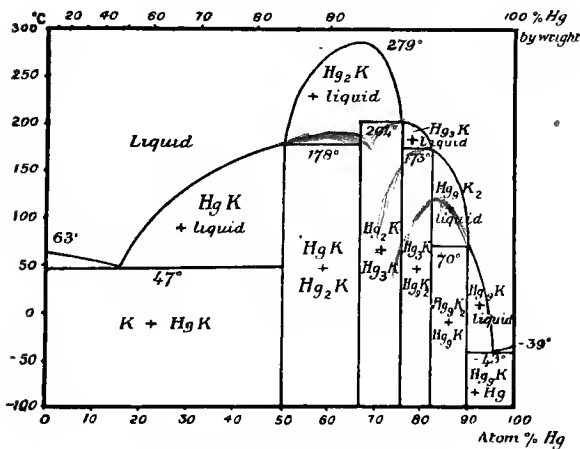

FIG. 15.—Mercury and potassium.

The system potassium-mercury (Fig. 15) is considerably more complicated. There is only one maximum, that corresponding with the remarkably stable compound Hg_2K , melting 216° higher than the less fusible of its two components. The breaks in the curve, however, indicate no less than four other compounds, undergoing decomposition below their freezing-points, namely, HgK , Hg_3K , Hg_9K_2 , and Hg_9K . Time curves were not recorded in this investigation.

Other examples of the kind of diagram described in this section are given in the Appendix; the formula of the inter-metallic compound being given in each case.

CHAPTER III

THE DIAGRAM OF THERMAL EQUILIBRIUM (*continued*)

SOLID SOLUTIONS OR MIXED CRYSTALS

IN all the cases hitherto considered, the component metals or their compounds have been assumed to crystallize from the molten alloy in a pure state. More frequently, however, the mutual solubility of the components which is evident in the liquid state also persists, although usually to a smaller extent, in the solid state. That is to say, in the majority of cases the crystals of M which separate on cooling contain a greater or less quantity of N, and this not mechanically retained, but in a state of true solution. We may speak of true solution in the case of solids whenever we find homogeneous crystals of two or more components, the composition of which may be varied continuously within certain limits. A "solid solution" (the term is due to van't Hoff) is therefore a single phase. Certain pairs of metals are isomorphous, that is, they crystallize together in all proportions to form homogeneous crystals, the properties of which vary in a continuous manner from one end of the series to the other. Others, although crystallizing in different forms, are each capable of crystallizing with a small quantity of the second metal, which is thus constrained to take up a crystalline form foreign to it. The term "solid solution" is sometimes retained for the cases in which there is no resemblance of crystalline form, isomorphous mixtures being placed in a separate class, but in the absence of any exact knowledge of the distinction, it is better to group together solid solutions of all kinds. Roozeboom introduced the word "Mischkrystall" for a solid solution, both components of

which are crystalline, and this term is now very generally used. The usual English rendering "mixed crystals" is in some ways unfortunate, since it suggests to the mind rather a conglomerate than a single phase. For this reason, the older term "solid solution" will be preferred in the present work.

It is probable that all metals should be regarded theoretically as possessing some degree of mutual solubility, however slight, in the solid state, the condition of complete insolubility considered in the preceding chapter being regarded as an ideal limiting case. The quantity held in solution is, however, frequently so small as to be negligible in practice. When the solubility is too small to be recognized by thermal methods, microscopical investigation affords valuable assistance.

The different types of equilibrium in which solid solutions can co-exist with liquid alloys have been worked out by Roozeboom¹ and by Bruni.² Whereas Bruni employed the temperature-concentration diagram of which use has been made in the preceding chapter, Roozeboom based his exhaustive study of the subject on the highly abstract principle of the thermodynamical potential. Both authors arrived at very similar results, and their conclusions may now be regarded as firmly established. For the practical purposes of metallography, the method of the temperature-concentration diagram is the only available one, and will be employed exclusively, although the systems discussed will be referred to the types of Roozeboom's classification, as being the more complete and systematic.

The two component metals may be isomorphous, in which case only a single series of solid solutions is formed, their properties varying in a continuous manner from the one end of the series to the other. It is easy to show that the freezing-point curve of such a series must be continuous. The points at which the direction of a freezing-point curve changes suddenly in direction, so that two intersecting tangents to the curve may be drawn at the same point, are *invariant* points, at which the number of co-existing phases, vapour being

¹ H. W. Bakhuis Roozeboom, *Zeitsch. physikal. Chem.*, 1899, **30**, 385.

² G. Bruni, *Rend. R. Accad. Lincei*, 1898, [v.] **7**, ii. 138, 347.

excluded, exceeds the number of components by one. A series of solid solutions, however, constitutes but a single phase, and since the only other phase present is the liquid alloy, the number of co-existing phases never exceeds two. By our simplified formula

$$f_1 = n - p + 1 = 2 - 2 + 1 = 1$$

that is, the system always has a degree of freedom, and the freezing-point curve cannot exhibit a discontinuity.

Systems of this kind have been grouped in three different classes, according as the freezing-point curve lies wholly

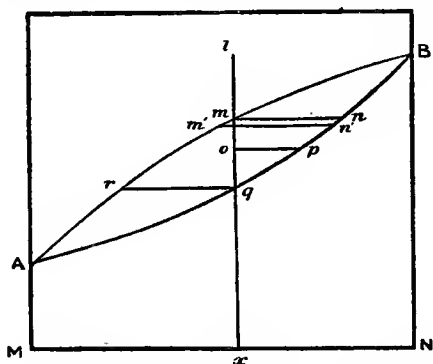

FIG. 16.—Solid solutions, Type I.

between the freezing-points of the two components (Type I.), or presents either a maximum (Type II.) or a minimum (Type III.). The first and third of these types are met with in alloys.

Type I.—The freezing-points of alloys of isomorphous metals frequently lie entirely between the freezing-points of the pure metals. There is, then, no alloy in the series which on freezing deposits crystals having the same composition as the liquid with which they are in contact. The liquid phase is always proportionately richer than the solid phase in that component, the addition of which lowers the freezing-point.

In Fig. 16, the two isomorphous metals melting at A and

B respectively, form a continuous series of solid solutions. We will assume that the freezing-point curve is concave to the concentration axis, as A_mB . An alloy containing Mx per cent. of the metal N and Nx per cent. of the metal M will, on cooling from the molten state, be represented by a point travelling down lm . At the point m , crystallization sets in. But in accordance with what has been said above, the crystals contain comparatively less of the metal M than does the liquid,—they have a composition represented, let us suppose, by n . As freezing continues, the composition of the liquid is expressed by a point travelling down mA towards A, the solid phase being successively represented by points on a second curve, npA , which lies throughout its length to the right of A_mB . Roozeboom has called the curve which represents the composition of the liquid phase the “liquidus,” and that which represents the composition of the solid phase the “solidus.” The solidus lies entirely below the liquidus, and since the two coincide at A and B, where both liquid and solid phases consist of the pure metal, the solidus must always be less concave or more convex towards the concentration axis than the liquidus.

When the temperature has fallen to q , the last of the alloy solidifies, and mq is called the “crystallization interval.” But it will be seen that the last portions of the liquid had the composition r , and could not therefore deposit crystals of the composition q . It follows that the solid phase is only represented by q as regards its *average* composition, unless some further change occurs beyond those described above. The further change, in conditions of complete equilibrium, is one of diffusion in the solid phase. For example, the crystals deposited when the composition of the liquid phase has changed by an infinitesimal amount, say from m to m' , will have a composition represented by a point lying somewhat to the left of n' . But the first crystals deposited had the composition n , so that the solid phase can only become homogeneous, a condition necessary for equilibrium, by diffusion, the final result of which is the production of entirely homogeneous crystals of the composition n' . This readjustment by

diffusion must take place at each stage in order that the solid phase may remain homogeneous. Since diffusion in a solid is very slow in comparison with crystallization from a liquid, complete equilibrium is only attained when the cooling of the alloy through the solidifying range of temperature is extremely slow. This condition is rarely completely fulfilled in practice, and the crystals deposited from the molten alloy therefore fall short of complete uniformity of composition. It is possible, by heating the alloy for a long time at a temperature somewhat below the melting-point, to cause diffusion to take place, and such an "annealing" process is generally necessary to destroy the heterogeneous structure of solid solutions.

If we suppose that no diffusion whatever takes place in the solid state, but that crystals of different composition remain in contact with one another without change, the solidified alloy will be represented at successive temperatures by points lying on a curve nr . It will still be true that the curve nq will represent the average composition of the solid phase, but the crystals will be composed of concentric layers of progressively changing composition. In practice, the conditions are intermediate between those of complete equilibrium and of entire absence of diffusion, and the crystals obtained are therefore heterogeneous, but less so than in the second hypothetical case. The effect of such imperfect equilibrium on structure will be discussed in connection with the microscopical study of alloys.

The process of melting reverses the course of events observed on freezing. The alloy x remains solid until the point q is reached on the solidus curve, when the first drop of liquid appears, having the composition r if we assume conditions of complete equilibrium. The last portions of the alloy liquefy at the point m . We see, therefore, that the solidus curve, as well as representing the composition of the solid phase in equilibrium with liquid at each temperature, also indicates the temperature at which the first appearance of liquid occurs when any alloy of the series is heated. It may therefore be regarded as the melting-point curve, the liquidus being the freezing-point curve.

Since the process of crystallization of a solid solution is a

gradual one, extending over an interval of temperature, the cooling curve of such an alloy cannot have the same form as that of an alloy belonging to a eutectiferous series, such as those described in the last chapter. The characteristic form is that shown in Fig. 17. The portion ab represents the cooling of the liquid alloy. The first separation of crystals at b is well marked, but the curve then assumes a rounded form, and

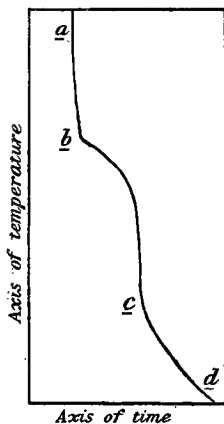

FIG. 17.

the final solidification of the remaining mother-liquor, instead of producing a horizontal arrest-line as in the case of eutectiferous alloys, is only indicated by a slight change of direction at c , where the curve of solidification, bc , joins the cooling curve of the solid alloy, cd . This change of direction is sometimes difficult to observe, the two portions of the curve appearing to pass smoothly into one another. An application of Plato's method of cooling (see p. 102) would probably increase the distinctness of the break, but under the ordinary conditions of working, the determination of the solidus curve and of the interval of solidification

are far less accurate than the other determinations needed in constructing a thermal diagram.

Examples of complete isomorphism are most abundant among the metals of high melting-point, such as the platinum and iron groups, and gold, silver, and copper. The diagrams of the alloys of gold and platinum (Fig. 18) and of copper and nickel (Fig. 19) are typical of such isomorphous pairs of metals. The interval between the liquidus and solidus curves may be large or small. It will be noticed that the two curves are much further apart in the gold-platinum series¹ than in the copper-nickel series.² A result of this is that rapidly cooled alloys of copper and nickel are likely to be much more nearly

¹ F. Doerinckel, *Zeitsch. anorg. Chem.*, 1907, 51, 333.

² N. S. Kurnakoff and S. F. Schemtschuschny, *ibid.*, 156.

homogeneous than alloys of gold and platinum cooled under the same conditions, that is, the incompleteness of the equilibrium has a smaller influence in the former case. If the liquidus and solidus curves were to approach one another still more closely, they might be imagined to coincide, in which case the solid and liquid phase in equilibrium with one another at any temperature would be identical in composition. It is

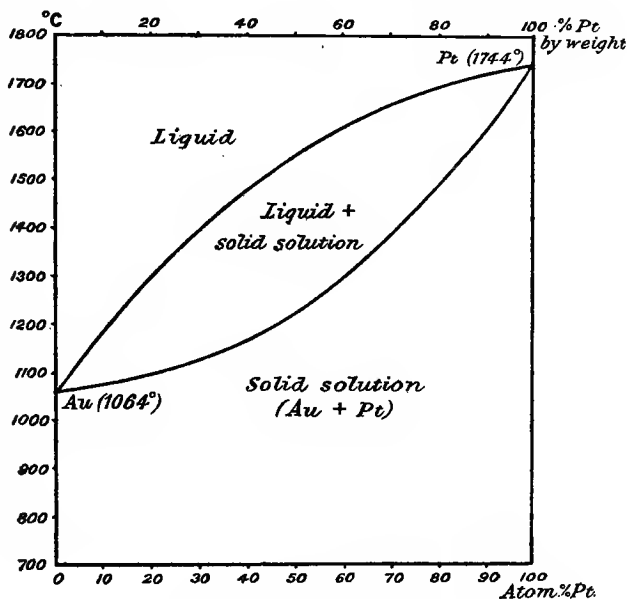

FIG. 18.—Gold and platinum.

very improbable that this case ever occurs in alloys, and there are theoretical reasons for supposing it to be impossible.¹

Type II., in which the freezing-point curve presents a maximum, has only been observed so far in organic optical isomerides, and not in alloys. The nature of the diagram will be readily understood from a comparison with *Type III.* The liquidus and solidus curves coincide at the maximum.

¹ J. J. van Laar, *Zeitsch. physikal. Chem.*, 1906, 55, 435.

Type III.—The metals form a continuous series of solid solutions, the freezing-point curve passing through a minimum.

This type may be illustrated at once by a concrete example, the alloys of copper and manganese (Fig. 20).¹ The freezing-point of each component is lowered by addition of the other, but there is no eutectic point, the liquidus curve being continuous throughout. Where it passes through a minimum the

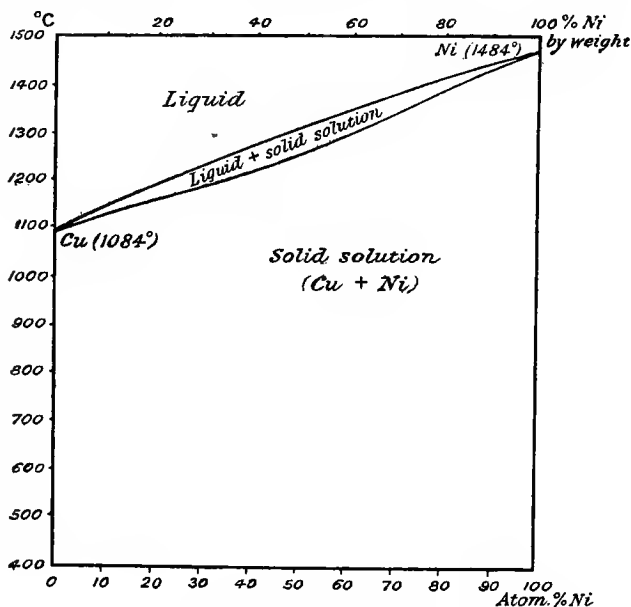

FIG. 19.—Copper and nickel.

solidus and liquidus curves coincide, so that at that point the solid and liquid phases have the same composition. At all intermediate points on the curve the composition of the solid phase differs from that of the liquid with which it is in contact, the relation between the two being found by the method

¹ S. F. Schemtschuschny, G. Urazoff, and A. Rykowkoff, *Zeitsch. anorg. Chem.*, 1908, 57, 253.

described on page 45. The remarks there made as to the effect of imperfect equilibrium apply in this case also.

Since the alloy of minimum freezing-point solidifies at constant temperature, its cooling curve has a horizontal portion like that characteristic of a pure metal or a eutectic alloy. A mere determination of the liquidus would in fact suggest that the series was eutectiferous, the trough-like form of the curve near the minimum not being readily distinguishable from the intersection of two lines. A determination of the solidus

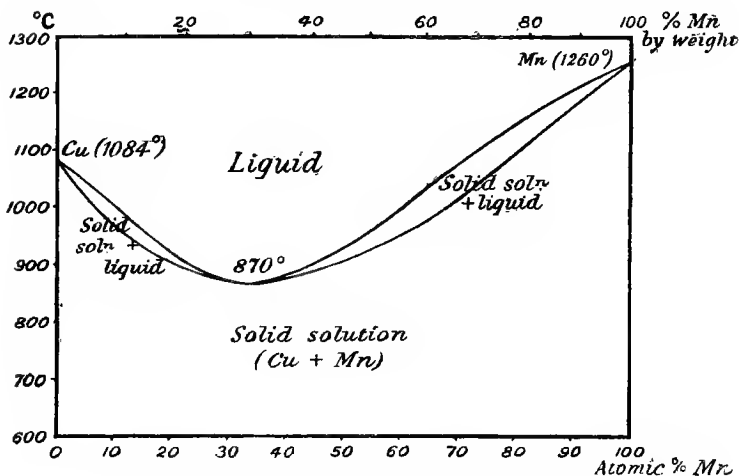

FIG. 20.—Copper and manganese.

curve, however, enables the two conditions to be distinguished with certainty. The eutectic horizontal is absent, the solidus taking the form of a continuous curve, convex throughout to the axis of concentration. As the accurate determination of the solidus is a matter of considerable difficulty, this is essentially a case in which the thermal and microscopical investigation should go hand in hand, since the absence of the characteristic eutectic structure, and the presence of homogeneous crystals of the solid solution at the minimum point, should be readily detected by the latter method. The

determination of the electrical conductivity is also a most valuable aid in doubtful cases.¹

How necessary such a control may be is well seen in the case of the alloys of copper and gold. In spite of the importance of these alloys in coinage, their constitution has only recently been studied in detail. The liquidus curve was determined by W. Roberts-Austen and T. K. Rose,² who regarded it as being composed of two branches, meeting in a shallow eutectic trough. They were unable, however, to observe any eutectic arrests on the cooling curves, or to determine any points on the solidus. A determination of both liquidus and solidus³ leads to the conclusion that the curve is of the type just discussed, a continuous series of solid solutions being formed. This is in accordance with the evidence of the microscope⁴ and of the electrical conductivity.⁵

¹ S. Wologdine (*Rev. de Métall.*, 1907, 4, 25) has given an entirely different diagram for the copper-manganese alloys, in which a maximum occurs, corresponding with the composition Cu_3Mn , a eutectic being formed on the manganese side of the maximum. This is, however, inconsistent with the microscopical and electrical properties of the alloys. Since Wologdine used charcoal to hinder oxidation, it seems probable that his results are to be explained by the presence of carbide. This is confirmed by the fact that his alloys, rich in manganese, disintegrated in air, evolving hydrocarbons, a behaviour which is not observed with pure alloys of the two metals. The data from which Fig. 20 was constructed were obtained from alloys melted either in a current of hydrogen or under a layer of barium chloride, the two methods giving identical results. The results of R. Sahmen, *Zeitsch. anorg. Chem.*, 1908, 57, 1, obtained with impure material, are in rough agreement with those of Schemtschuschny.

² *Proc. Roy. Soc.*, 1900, 67, 105.

³ N. S. Kurnakoff and S. F. Schemtschuschny, *Zeitsch. anorg. Chem.*, 1907, 54, 149.

⁴ Roberts-Austen and Rose obtained photo-micrographs of certain of these alloys in which a laminated structure, characteristic of eutectics, was visible under very high magnifications. Nothing of the kind was observed by the Russian investigators. There is thus a conflict of evidence, which may be explained in one of three ways:

1. There may be a stable and a metastable system, only one of which is eutectiferous, and either the one or the other may be obtained, according to the conditions of cooling.
2. The system may be of Type V. (p. 55) with a very small gap between the two solid solutions.

The alloys of manganese and nickel form a series of Type III., closely resembling those of copper and manganese.⁶

More complicated forms of the freezing-point curve, which may present a point of inflexion, or both a maximum and a minimum, may in theory be presented by alloys forming a continuous series of solid solutions,⁷ but such forms have not been observed in metallic alloys in the absence of compounds; it is therefore unnecessary to discuss them here. All such curves are subject to the condition that wherever the solidus and liquidus coincide, so that the solid and liquid phases have the same composition, the common tangent to the two curves at that point must have a horizontal direction.

The next case to be considered is that in which the two metals have only a limited reciprocal solubility in the solid state. If we compare a pair of isomorphous metals with two completely miscible liquids, such as alcohol and water, the alloys of the present type are comparable with a pair of liquids such as water and ether, of which each can dissolve a certain limited proportion of the other, so that all mixtures richer than the limiting value separate into two layers, consisting of saturated solutions of water in ether, and of ether in water respectively. In the same way, certain pairs of metals may form two series of solid solutions, and any alloys falling between the limits of saturation must consist of a complex of two phases, each of which is a saturated solid solution.

In the simplest case (Roozeboom's Type IV.) the two series of solid solutions meet at a transition point, as indicated in Fig. 21. The two branches of the freezing-point curve, AC and CB, have each a corresponding solidus, AD and EB respectively. At the temperature of the transition point C, there are two solid phases in simultaneous equilibrium with the liquid, C is therefore an invariant point, and the transition from

3. The supposed eutectic structure may be in reality a strain-structure due to contraction during cooling, as observed in certain cases by Beilby. The last explanation is the most probable.

⁶ A. Matthiessen, *Phil. Trans.*, 1861, 150, 161.

⁶ Schemtschuschny, Urazoff, and Rykowkoff, *loc. cit.*

⁷ R. Ruer, *Zeitsch. physikal Chem.*, 1907, 59, 1.

one series of crystals to the other, indicated by the line CE, must take place at constant temperature, that is, CE must be horizontal. The arrangement of fields will be seen from the diagram. All alloys lying to the left of C solidify as crystals of the solid solution α , as in Type I. Similarly, alloys to the right of E form only crystals of the solid solution β . Alloys between C and D at first deposit crystals of β , but on cooling past the transition temperature these are converted into the stable form α . All alloys between D and E form, when solid,

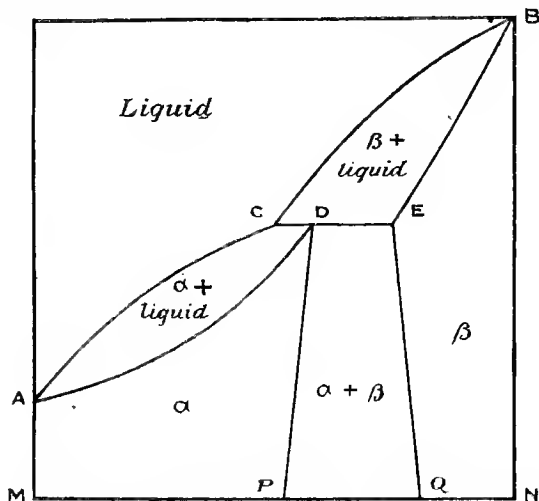

FIG. 21.—Solid solutions, Type IV.

a complex of saturated α and β crystals, having the compositions D and E respectively. Such a complex is the exact analogue of a mixture of water and ether which has separated into two layers. Varying the composition of the alloy between the two limits D and E changes only the relative proportion of the two phases, without altering their concentration.

The lines DP and EQ have been drawn with a slight inclination from the vertical, since the solubility of one solid metal in another, like that of liquids, usually decreases with falling temperature, so that, sufficient time being given to

establish equilibrium, the composition of the two saturated solid solutions, α and β , will change to a certain extent with the temperature. The inclination of such lines has been studied in a very few cases, the best known of which are the alloys of copper with zinc and tin respectively. These cases will be discussed fully later. The simple case represented in Fig. 21 has an excellent representative in the series cadmium-mercury. The cadmium amalgams form two series of solid solutions, and the ordinates of the points of intersection are—

A	Pure Hg,	-38°	
C	65 atom. per cent. Cd,	$+190^{\circ}$	
D	75	"	"
E	77	"	"
B	Pure Cd,	$+322^{\circ}$	

The lines DP and EQ diverge at lower temperatures, the limits of the two solid solutions being at 25° , for instance, 65 and 79 atom. per cent. Cd respectively. It was only found possible to determine the liquidus curve by measurements with the thermometer, the thermal changes indicated by the other lines of the diagram being so small as to escape observation, hence it was found necessary to complete the investigation by studying other physical properties of the amalgams. The position of the solidus was in fact determined from measurements of volume in the dilatometer, and that of the lines DP and EQ from measurements of electromotive force.¹

Liquidus and solidus curves of this type, although not often found representing a complete series, such as that of the cadmium amalgams, are of frequent occurrence when compounds are present, in which case they naturally form only a part of the entire equilibrium diagram.

The next case (Roozeboom's Type V.) occurs very frequently. Two limited series of solid solutions are now formed, between the limits of which a eutectiferous series of alloys occurs (Fig. 22). The lettering corresponds with that

¹ H. Bijl, *Zeitsch. physikal. Chem.*, 1902, **41**, 641. See also N. A. Pushin, *Zeitsch. anorg. Chem.*, 1901, **36**, 201.

of Fig. 21. The two branches of the liquidus now intersect at a eutectic point, C, at which the two saturated solid solutions are at once in equilibrium with the liquid phase. The eutectic horizontal, DE, does not reach the limits of the diagram, as in the cases considered in Chapter II., but stops short at the limits of saturation of the two series of solid solutions. This is, in

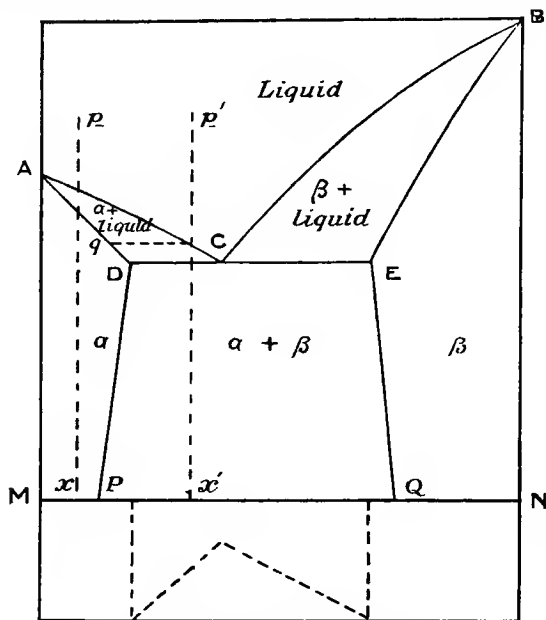

FIG. 22.—Solid solutions, Type V.

fact, the means by which we detect the formation of solid solutions in a eutectiferous series of alloys.

We will now consider what happens during the solidification of alloys of this series. A liquid alloy represented by the point p will, on cooling, deposit crystals of the solid solution α , and its cooling curve will be of the form shown in Fig. 17. A liquid alloy represented by p' , however, at first deposits crystals of α , and the composition of these crystals changes from q to D as the temperature falls. At the point D, the α

crystals are saturated, that is, they are incapable of taking up any further quantity of the second metal. The point C is then a eutectic point, at which the two phases D and E (saturated α and β crystals respectively) separate simultaneously. The cooling curve therefore differs from Fig. 17 in that the part bc is separated from cd by a horizontal portion corresponding with the solidification of the eutectic. The curve of eutectic arrest times is shown in the lower part of Fig. 22. When the development of heat during the solidification of the eutectic is small, extrapolation of the time curve to cut the zero line is

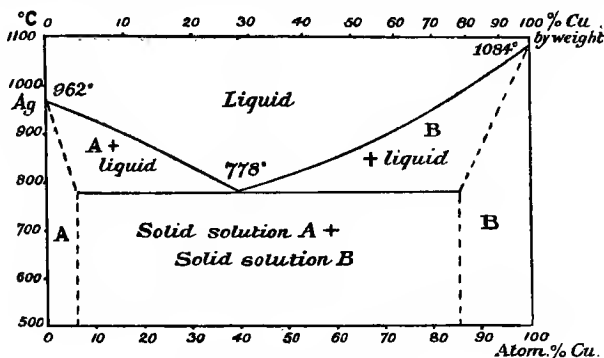

FIG. 23.—Silver and copper.

uncertain, and a more accurate determination of the position of the points D and E is obtained by microscopical examination.

A good example of this type is furnished by the alloys of silver and copper. The freezing-point curve was accurately determined by Heycock and Neville,¹ who, however, did not fix the position of the points D and E. The complete diagram, constructed from the experimental data of Friedrich and Leroux,² is shown in Fig. 23. Since, however, the results of the microscopical investigation of these alloys are not in agreement with the thermal diagram, it would appear that equilibrium is by no means readily obtained. It is probable that the

¹ *Phil. Trans.*, 1897, 189A, 25.

² *Metallurgie*, 1907, 4, 293.

eutectic arrest was observed beyond its true limits, so that the horizontal in Friedrich's diagram is too long. In drawing Fig. 23, the electrical conductivity as determined by Matthiessen¹ has been taken into account in fixing the probable limits of the formation of solid solutions. The solidus in this figure must therefore be regarded as approximate only.

The changes which may take place in an alloy during cooling are not at an end when the mass has solidified. Crystallization from solution, change from one solid phase to another of different crystalline form, even chemical reactions between the constituents, are possible in the solid state without the presence of a liquid solvent, although the velocity of such changes is in general less than when a liquid is present. The first case to be considered is that of a metal or inter-metallic compound which exists in more than one crystalline form, having different temperature ranges of stability. Such a substance is said to be *polymorphic*; when cooled, it shows a change of properties at a definite temperature, the *transition temperature*, and the change is generally accompanied by a development of heat, making itself known as a further arrest in the cooling curve. Such heat-changes are often comparatively slight, and are not readily detected on the ordinary temperature-time curve, special differential and other methods have therefore been devised for their recognition, and will be described in the chapter on practical thermal measurements.

The number of polymorphic metals and inter-metallic compounds is very great, and the equilibrium diagrams of alloys owe a large part of their complexity to this cause. When the polymorphic metal or compound occurs in a eutectiferous series, it undergoes the same change whether present as primary crystals or as a constituent of the eutectic, and the transformation takes place at the same temperature in both cases. The polymorphic change is therefore represented by a

¹ *Pogg. Ann.*, 1860, 110, 190. The microscopical examination of alloys of this series after annealing for different periods, by W. von Lepkowski, *Zeitsch. anorg. Chem.*, 1908, 59, 285, also points to the existence of solid solutions over a range similar to that indicated in the diagram.

horizontal line extending over the same limits as the eutectic. When, on the other hand, the polymorphic metal forms solid solutions, the transition temperature varies with the composition. Moreover, it has been shown by Roozeboom¹ that the transformation of a solid solution, like its solidification, must take place over a certain interval of temperature, so that we have two curves, representing the beginning and the end of the polymorphic change, and corresponding very closely with the liquidus and solidus curves already studied. This will be understood by reference to Figs. 24 and 25. In the former of these, both the low and the high temperature modifications of the two metals are assumed to be completely isomorphous. In the second figure, only one of the components of the isomorphous series is assumed to undergo a change on cooling.

It may happen that the solid solution breaks up into its components on cooling, and the diagram then assumes the form shown in Fig. 26. The temperature at which each component crystallizes from the solid solution is lowered by addition of the other, and we consequently obtain two transformation curves. The resemblance of this curve to the freezing-point curve of a eutectiferous series is at once apparent, and the analogy is a real one. Primary separation of the components takes place along the two curves, and when the temperature of intersection is reached, the remaining solid solution splits up into a conglomerate of the two components. From the resemblance of this alloy in its physical properties as well as in its mode of formation to a eutectic, it is called a *eutectoid*.² The best-known examples are those of the iron-carbon and copper-tin series, and these are illustrated in Figs. 27 and 28. Fig. 27 is a small part of the complete diagram of the iron-carbon alloys, constructed from the data of Carpenter and Keeling.³ The homogeneous solid solution

¹ *Zeitsch. physikal. Chem.*, 1899, **30**, 385.

² H. M. Howe, *Metallographist*, 1903, **6**, 249. The word "aeolic" had been previously used, but not generally adopted. (See Howe, *Iron, Steel, and other Alloys*, Boston, 1903.)

³ H. C. H. Carpenter and B. F. E. Keeling, *J. Iron Steel Inst.*, 1904, i. 224.

breaks up on cooling, setting free pure iron and iron carbide, Fe_3C . Pure iron separates along the left-hand curve, but at 760° a polymorphic change takes place, described as the trans-

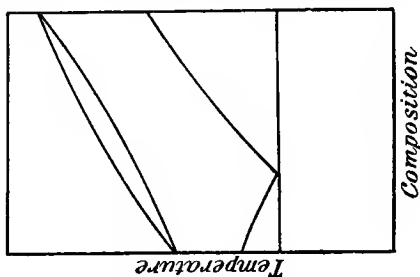

FIG. 26.

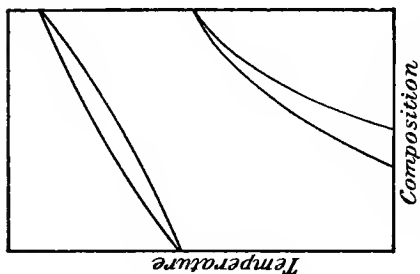

FIG. 25.

Polymorphic changes in solid solutions.

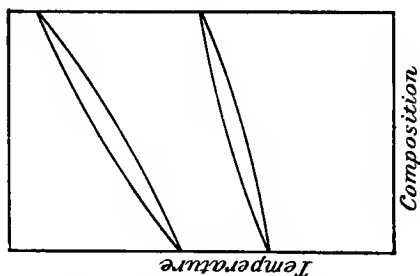

FIG. 24.

formation of β - into α -iron. Since the metal is pure, this change takes place at constant temperature. The remainder of the curve now represents the separation of α -iron from the solid

solution. Passing to the alloys richer in carbon, the carbide crystallizes along the right-hand branch, intersecting the other at the eutectoid point, at which the remaining solid solution splits up into a finely laminated conglomerate of iron and carbide, known as *pearlite*. All alloys comprised within the limits of the diagram show an arrest on their cooling curves at 690° , corresponding with the formation of pearlite. The heat-development reaches a maximum at the eutectoid composition, that is, at 0.89 per cent. of carbon.

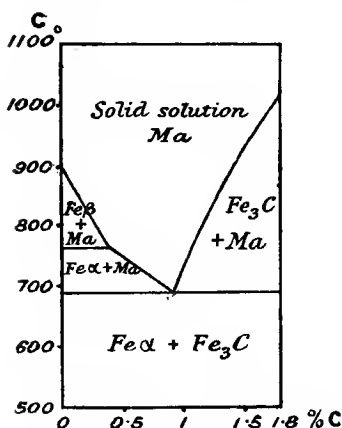

FIG. 27.—Iron and carbon.

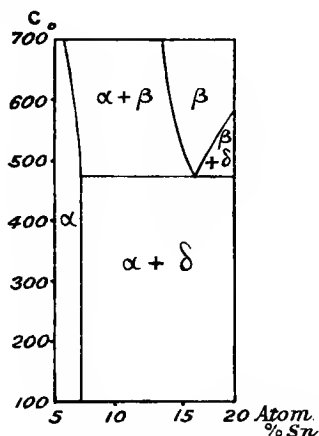

FIG. 28.—Copper and tin.

The curve in Fig. 28 is taken from Heycock and Neville's diagram of the copper-tin alloys.¹ Alloys containing 17 atomic per cent. of tin contain a solid solution at 550° , which on further cooling breaks up into crystals of copper and of another substance, possibly Cu_4Sn . The eutectoid composed of these two constituents has a very characteristic structure. Both of these series of alloys will receive fuller treatment in a subsequent chapter.

It was mentioned above that when two solid solutions are

¹ *Phil. Trans.*, 1903, 202A, 1. A slight modification has been introduced, made necessary by the work of F. Giolitti and G. Tavanti, *Gazzetta*, 1908, 38, ii. 209.

in equilibrium with one another, their composition usually changes as the temperature falls, so that the lines separating the different fields are not vertical, but inclined or curved. This is well illustrated by the alloys of copper and zinc. Fig. 29 is a portion of the diagram.¹ Alloys containing 38 to 52 per cent. of zinc are homogeneous at 800°, forming the β solid solution. At lower temperatures, those rich in copper throw out crystals of a second solution, α , whilst those rich in zinc throw out crystals of a compound, Cu_2Zn_3 . This crystalli-

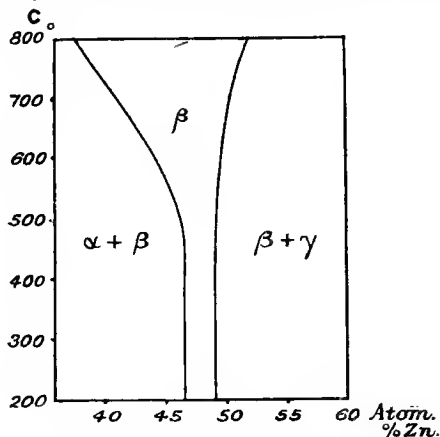

FIG. 29. — Copper and zinc.

zation proceeds as the temperature falls, so that the field of the β solution becomes progressively narrower with decreasing temperature.²

It is possible for the components of a solid solution to enter into combination to form a definite compound on cooling, or the components may each separately undergo a polymorphic change, and the low-temperature modifications

¹ E. S. Shepherd, *J. Physical Chem.*, 1904, 8, 421; V. E. Tafel, *Metallurgie*, 1908, 5, 343.

² Later investigations (H. C. H. Carpenter and C. A. Edwards, *J. Inst. Metals*, 1911, 5, 127; H. C. H. Carpenter, *ibid.*, 1912, 7, 70; 8, 51) show that the condition represented above, although generally observed, is not a stable one, and that a eutectoid point exists at 470°, below which temperature the β -solution has no stable existence.

may combine. Such cases have been suspected, but not accurately observed, in alloys of metals of high melting-point. It will be well to examine a case of this kind, selected from an investigation of mixtures of fused salts,¹ in order to indicate the kind of results that may be expected

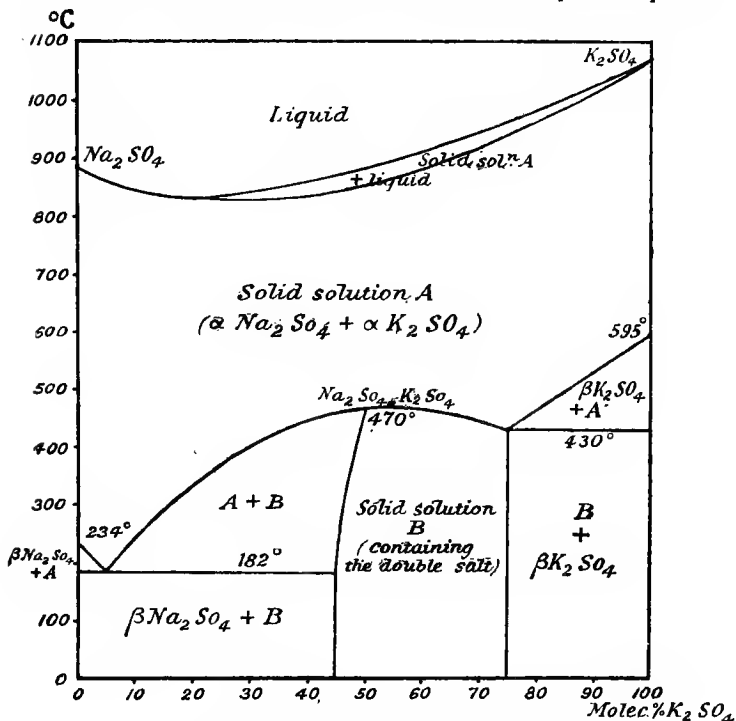

FIG. 30.—Sodium and potassium sulphates.

when such a reaction takes place. Mixtures of sodium sulphate and silver sulphate solidify to a homogeneous series of solid solutions, the freezing-point curve having a minimum at 20 mol. per cent. K₂SO₄ (Fig. 30). Sodium sulphate changes to a β modification at 234°, and potassium sulphate at 595°. There are two eutectoid points, at 5 and 75 mol.

¹ R. Nacken, *N. Jahrb. Min., Beil.-Bd.*, 1907, 24, 1.

per cent. K_2SO_4 respectively, and between them the transformation curve rises to a maximum corresponding with the double salt Na_2SO_4, K_2SO_4 ,¹ which forms solid solutions to a small extent with sodium, and to a much greater extent with potassium, sulphate. The conditions of equilibrium are readily seen on an inspection of the diagram. No parallel case is known with certainty amongst alloys, but similar conditions, namely the formation of a compound on cooling a series of solid solutions, have been suspected in the course of the study of alloys of cobalt and chromium.²

The occurrence of polymorphic change in the solid state provides an additional means of fixing the formula of an intermetallic compound, since the alloy consisting of the pure compound will show the maximum development of heat due to its transformation. This fact often provides a means of distinguishing between solid solutions containing a compound and those which consist only of the component metals in an uncombined state, Tammann's method of plotting arrest times against composition being applied to the transformation. It is unnecessary to give separate diagrams of such cases, as the mode of application will be obvious from what has been said above and will be further illustrated by concrete examples.

¹ Nacken (*loc. cit.*) does not regard this as a double salt, but only as a solid solution having a maximum on the transformation curve, since he finds that the density and crystalline form change continuously. The whole form of the diagram is, however, such as to indicate a compound.

² K. Lewkonja, *Zeitsch. anorg. Chem.*, 1907, 59, 293.

CHAPTER IV

THE DIAGRAM OF THERMAL EQUILIBRIUM (*continued*)

TERNARY AND MORE COMPLEX ALLOYS

THE methods of investigating alloys of three or more metals are the same in principle as when the simpler alloys of two metals are dealt with, but the experimental difficulties, and the complexity of the conditions which may present themselves, are naturally much greater. For this reason, in spite of the number of alloys of technical importance containing three metals, very few ternary systems have been examined with any degree of completeness, and the study of quaternary alloys remains an untouched field. The thermal investigation of any such complex system involves a very large number of separate experiments, and all the sources of error met with amongst binary alloys recur in an aggravated form, the consequence being that the construction of the diagram of thermal equilibrium of a ternary system is an undertaking of considerable magnitude. The task is simplified when the object of the research is technical rather than scientific, since the alloys capable of being utilized in practice are most commonly confined within comparatively narrow limits of composition, the remaining alloys of the system being useless for the purposes of industry on account of brittleness or other undesirable properties. It is, therefore, probable that such investigations of limited regions, having a mainly practical object in view, will assume greater importance in future metallographic research, although it is to be hoped that investigators will also

be found to carry out the complete study of a sufficient number of these highly interesting systems.

The thermal equilibrium of a ternary system can only be represented graphically by a diagram or model in three dimensions. The method employed in metallography is that due in the first place to Willard Gibbs,¹ but more generally associated

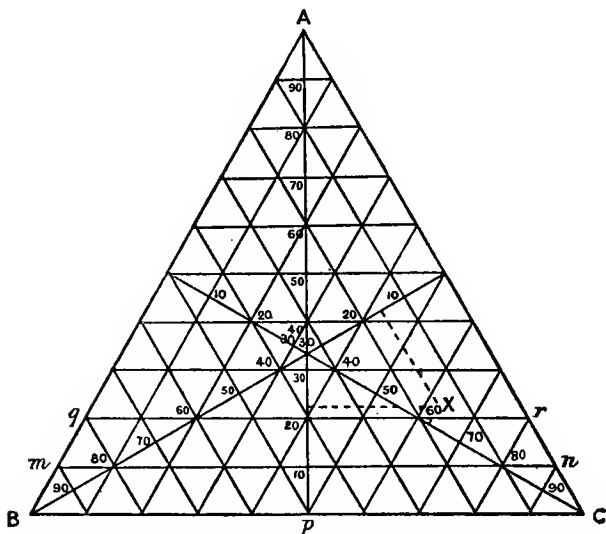

FIG. 31.—Graphical representation of a ternary system.

with Stokes, who independently devised the same scheme,² basing it on the method employed by Clerk Maxwell for the composition of colours.³

The percentage compositions of the alloys are represented by an equilateral triangle, the height of which is 100 (Fig. 31). The three points A, B, and C there represent the pure metals,

¹ *Trans. Connecticut Acad.*, 1876, 3, 176.

² *Proc. Roy. Soc.*, 1891, 49, 174.

³ Graphical methods of converting percentages by weight into atomic percentages in ternary systems are given by F. Hoffmann, *Metallurgie*, 1912, 9, 133, and E. Jänecke, *ibid.*, 320.

a point on the line AB represents a binary alloy of A and B, and so on for the pairs AC and BC, whilst any point within the triangle corresponds with an alloy of the three metals. The composition of such an alloy is readily found by measuring the perpendicular distance of the point from each of the sides. Thus an alloy represented by X consists of 23 per cent. of the metal A, 15 per cent. of B, and 62 per cent. of C. The perpendiculars from A, B, and C on to the opposite sides being each divided into 100 parts, the composition of any alloy is expressed on the diagram by measuring distances proportional to the percentages of two of the three constituents present in directions parallel with the corresponding perpendiculars, the measurement of the third being superfluous, since the sum of the three perpendiculars from a point are always equal to the height of the triangle, that is to 100. It facilitates plotting if the triangle is divided up into smaller triangles by ruling lines parallel with the sides through each tenth graduation on the perpendiculars, as shown in the figure.

The ordinates of temperature are now erected as perpendiculars to the plane of the triangle, and their summits are joined to form a surface or a system of surfaces, so that the space-model ultimately obtained is a vertical triangular prism. When only the freezing-point surface, or liquidus, is studied, the representation in three dimensions may be dispensed with, the diagram taking the form of a projection of the surface and its contour lines on the basal plane, the temperatures being written in at all important points. This graphical method will be employed for the simpler cases. When, however, the solidus surface and the temperatures of transformation in the solid state have to be taken into account, such a projection becomes so complicated as to be impracticable. The best general view of such a system would be given by constructing the space-model in a transparent material, such as celluloid, the various surfaces being represented by plates of the material, coloured if necessary, bent to the required shape and cemented in place. Such a model would be best for purposes of demonstration, but a solid space-model is inconvenient when it is required to read off the phase equilibrium of a given alloy,

and some artifice becomes necessary in order that the results may be expressed in the form of plane diagrams. We may employ a series of projections on triangles representing the basal plane, each projection corresponding with a transformation. A simpler plan, and one giving a much clearer view of the equilibrium, is that of constructing a series of *vertical* sections of the space-model. This has the further advantage of coinciding with the plan usually adopted in the systematic practical investigation of such alloys. For instance, a series of alloys of A, B, and C are examined in which, while the proportions of B and C are varied, that of A remains constant, say 10 per cent. The results obtained may be plotted to form a plane thermal diagram, which is really a vertical section of the space-model, cut through the point 10 on $A\bar{p}$, in a direction parallel with BC, so that its base is the line mn . A second similar series is examined, containing 20 per cent. A, and a second section, having the base qr , is thus obtained. A series of similar sections can be built up to give the space-model. It is obvious that if, after the completion of the experiments, it is required to bring out more clearly the variation in the alloys brought about by the gradual increase of B in the mixtures, the data already obtained allow plane sections to be drawn parallel with AC. When reviewing such a series of sectional diagrams, a little practice makes it easy to grasp the spacial arrangement of the phases in the system.

The freezing-point surface alone is often represented for purposes of demonstration, by erecting the ordinates as thin wires on a triangular wooden base, and filling up with plaster of Paris, smoothing off at the level of the ends of the wires. Perspective drawings or photographs of such plaster models are often found in papers dealing with ternary systems.

The possible forms of equilibrium in ternary systems are very numerous, and it is impossible to give an exhaustive review of them. A list of the principal memoirs on the subject is given below.¹ Only the two simplest cases will be discussed

¹ C. R. A. Wright and C. Thompson, *Proc. Roy. Soc.*, 1889, 45, 461; 1890, 48, 25; 1891, 49, 156; C. R. A. Wright, *ibid.*, 50, 372; 1892, 52, 11, 530; 1894, 55, 130; W. D. Bancroft, *J. Physical Chem.*, 1897, 1,

here, and the application of the method to more complex cases will then be illustrated by some concrete examples.

The two general cases to be considered are, firstly, that in which the three metals crystallize from the molten alloy in the pure state, neither solid solutions nor inter-metallic compounds being formed; and secondly, that in which the three metals are isomorphous, forming an unbroken series of solid solutions composed of any two or of all three of the components.

I. THE THREE METALS CRYSTALLIZE IN A PURE STATE

If we assume that the only solid phases which separate on cooling are the pure metals, neither compounds nor solid solutions being formed, the three binary systems obtained by taking the metals in pairs will each be of the form shown in Fig. 4, p. 19, and the space-model will therefore be a triangular prism, of which the three vertical faces are bounded at the top by V-shaped curves. The freezing-point surfaces which start from the angles of the prism intersect along three lines, forming three valleys. The eutectic temperature of a binary system may be regarded as the simultaneous freezing-point of the two component metals, and the addition of a third metal lowers this freezing-point, just as the addition of a second substance lowers the freezing-point of a pure metal.

The curves of intersection, or the bottoms of the valleys, therefore slope downwards from the outer faces to the interior of the prism. They finally intersect at a point, the *ternary eutectic point*, which necessarily represents a lower temperature than any of the binary eutectics. It is on the existence of such a ternary eutectic that the possibility of preparing the so-called "fusible

403; 1899, 3, 217; A. W. Browne, *ibid.*, 1902, 6, 287; W. C. Geer, *ibid.*, 1904, 8, 257; E. S. Shepherd, *ibid.*, 92; B. B. Kriloff, *Zeitsch. physikal. Chem.*, 1897, 24, 441; F. A. H. Scheinemakers, *ibid.*, 1904, 50, 169; 1905, 51, 547; 52, 513; H. W. B. Roozeboom and A. H. W. Aten, *ibid.*, 1905, 53, 449; G. Bruni, *Gazzetta*, 1898, 28, ii, 508; C. T. Heycock and F. H. Neville, *Trans. Chem. Soc.*, 1891, 59, 936; L. Mascarelli, *Atti R. Accad. Lincei*, 1907, [v.] 16, ii, 691; P. Goerens, *Metallurgie*, 1909, 6, 531; N. Parravano and G. Sirovich, *Gazzetta*, 1911, 41, i, 417, 478, 569, 621; in addition to those mentioned in this and the following chapter.

metals," melting below 100° , depends, a mixture of three metals in the eutectic proportion in such a case melting more readily than any possible mixture of the same metals taken two at a time.

The well-known ternary system, lead—tin—bismuth, is usually referred to this type.¹ Strictly speaking, the condition that the solid phases separating shall be the pure metals is not fulfilled here, since lead forms solid solutions to a limited extent with tin,² and a more thorough investigation would

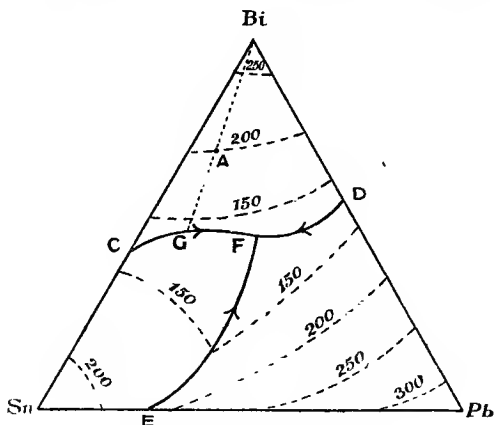

FIG. 32.—Bismuth, tin, and lead.

probably show the same to be true of the other pairs, but this fact does not affect the form of the freezing-point surface, which alone falls to be considered here. A projection of the surface on the basal plane of the prism gives the result shown in Fig. 32, in which the positions of the binary eutectic lines and of the ternary eutectic point are clearly seen.³ The dotted curves are isothermals, drawn at equal intervals of temperature,

¹ G. Charpy, *Compt. rend.*, 1898, 126, 1569; *Bull. Soc. d'Encouragement*, 1898, [v.] 3, 670.

² W. Rosenhain and P. A. Tucker, *Phil. Trans.*, 1908, 209A, 89.

³ The diagram is taken from Charpy, corrected by the later results of E. S. Shepherd, *J. Physical Chem.*, 1902, 6, 519, and recalculated into atomic percentages.

and connecting alloys of equal initial freezing-point; they may be best realized by considering them as the contour-lines of the solid model. As in a map, these contour-lines indicate the slope of the surface, which is steep when the lines are closely crowded together, and gradual when they are widely separated.

The process of crystallization of an alloy belonging to this system may now be followed in detail. If we consider a liquid alloy, the composition of which is represented by the point A, we shall see that the cooling of such an alloy will be represented by a point travelling down the perpendicular erected on the triangular base at the point A. This perpendicular cuts the freezing-point surface BiCFD, that is, the surface corresponding with the crystallization of bismuth. The position of the isothermal indicates that the separation of bismuth begins at 200° . The passage of a part of the bismuth from the liquid to the solid state does not alter the relative proportions of lead and tin in the portion remaining liquid, and the change of composition of the liquid alloy with falling temperature is therefore represented by a point travelling along the line BiAG from A towards G. When G is reached, this line intersects the eutectic line CF, which represents a system in which solid bismuth and solid tin are simultaneously in equilibrium with the liquid mother-liquor. A eutectic alloy of bismuth and tin therefore separates. The relative proportion of the two solid phases in the eutectic changes somewhat as the temperature falls, as is indicated by the line CF, which is not straight, but slightly curved. When the point F is reached, the whole of the remaining alloy solidifies at constant temperature. The ternary point F corresponds with the simultaneous equilibrium of one liquid and three solid phases, namely, the three pure component metals.

Examination shows that the process described accords with the indications of the phase doctrine. We are now dealing with a system of three components. When solid bismuth separates, there are two phases present, namely, the crystals of the solid metal, and the still liquid alloy. Since

$$f' = n - p + 1 \text{ (p. 25)}$$

$f' = 2$, or the system is divariant, and temperature and composition may be varied independently. When the first eutectic line is cut, a new phase appears, namely, solid tin. The number of phases being now three, the system is only univariant, so that, the temperature being given, the composition is also determined. At the ternary eutectic point F, four phases are in equilibrium, namely, the three solid metals and the liquid ternary eutectic, so that

$$f' = 3 - 4 + 1 = 0$$

the system is invariant, and can exist only at one definite temperature, the temperature indicated by F. It will be noticed that, on the space-model, bivariant systems are represented by surfaces, univariant systems by lines, and invariant systems, of which only one is possible in the case considered, by points. A three-dimensional region, such as that existing above the freezing-point surface, represents a trivariant system, since the concentration of two components, and the temperature, may be varied independently. Below the ternary eutectic temperature, three solid phases co-exist, and since we have assumed them to be perfectly immiscible, no change of composition can be brought about, and the phase rule ceases to be applicable. It again finds application in the cases to be considered immediately, in which the crystalline phases are not pure metals, but solid solutions, the composition of which depends on the temperature. To bring all such cases under the phase rule, we must assume that the solid metals are not completely immiscible, but that solid solutions are formed, if only to an inappreciably small extent. We then have three co-existing phases, and the system is univariant, so that a change of temperature brings about a change in the concentration of the solid solutions. The miscibility of solid components is a thermodynamical necessity, although it may occur only to an infinitesimal extent.¹

II. THE THREE METALS ARE ISOMORPHOUS

A continuous series of solid solutions is formed, and the freezing-point surface is a continuous one, bounded by the three

¹ R. Ruer, *Zeitsch. physikal. Chem.*, 1908, 64, 357.

freezing-point curves of the three binary systems. The projection on the basal plane shows no eutectic lines or points. The curvature of the surface may be indicated by means of contour lines. No experimental study of such a system yet exists, but there can be no doubt that the alloys of closely related isomorphous metals, taken in threes, will be found to conform to this type. Such, for instance, are the metals of the platinum series, together with gold. Thus, alloys of platinum, palladium, and gold, may be expected to form a ternary system of this simple type.

III. THE ALLOYS CONTAIN SOLID SOLUTIONS

A good example of a ternary series in which solid solutions are formed to a limited extent, no compounds being formed, is furnished by the mercury amalgams of cadmium and lead.¹ The three binary systems are of a simple type, and it is not necessary to reproduce the corresponding diagrams separately. Cadmium and lead form a eutectiferous series, the eutectic point lying at 249° and 33 atom. per cent. Cd. Each of these metals is capable of retaining small quantities of the other in solid solution, lead holding up to 4 atom. per cent. cadmium, and cadmium holding a very small percentage of lead. In the lead-mercury series, the eutectic point lies so near to the mercury end of the curve as to be indistinguishable from it, and solid solutions are also formed up to a concentration of about 40 atom. per cent. Hg. The cadmium-mercury diagram has been described in a previous chapter² Fig. 33 shows, above, an elevation of the space-model, and, below, the projection of the same on the base. The latter is divided into six fields, each of which corresponds with the primary separation of a distinct crystalline constituent from the molten alloy. The lines separating these fields, and the points at which these lines intersect, indicate the temperatures and concentrations at which different phases are in equilibrium. There is no ternary eutectic point, and only a single binary eutectic curve,

¹ E. Jänecke, *Zeitsch. physikal. Chem.*, 1907, **60**, 399 ; 1910, **73**, 328.

² Page 55.

aA , namely, that separating the regions of crystallization of lead and cadmium. The points k and D are not to be distinguished from the freezing-point of mercury, the second solution in the lead-mercury system being practically pure mercury, but for the sake of completeness their distance from the angle Hg of the triangle is exaggerated. The meaning of the points of intersection of the eutectic and transformation curves is shown in the following table:—

Point.	Character.	Phases in equilibrium with liquid.	Temp. °C.
a	Eutectic	Pb, Cd	249
b	Transformation	CdHga, HgCd β	188
k	„	PbHga, HgPb β	- 40
A	„	Pb, Cd, CdHga	235
B	„	Pb, Cd, HgCd β	169
C	„	Pb, PbHga, HgCd β	50
D	„	PbHga, HgPb β , HgCd β	- 40

The general behaviour of the alloys during solidification will be seen from a comparison of the upper and lower diagrams in Fig. 33. Consider an alloy represented by a point within the area $aACd$. As the temperature falls, it will deposit crystals of cadmium. Its composition then changes in the manner described in connection with the alloys of lead, tin, and bismuth (p. 71); the point representing it travels down the freezing-point surface until it reaches the line aA . The binary eutectic of lead and cadmium then separates, and the temperature continues to fall until the point A is reached. This is not a ternary eutectic point, but represents a reaction between the crystals and the mother-liquor, in accordance with the equation



The temperature remains constant at 235° so long as this reaction continues. If the cadmium is in excess, the mother-liquor solidifies completely at this temperature; but if the cadmium is used up in the reaction, and some liquid of composition A remains, this will fall in temperature, depositing

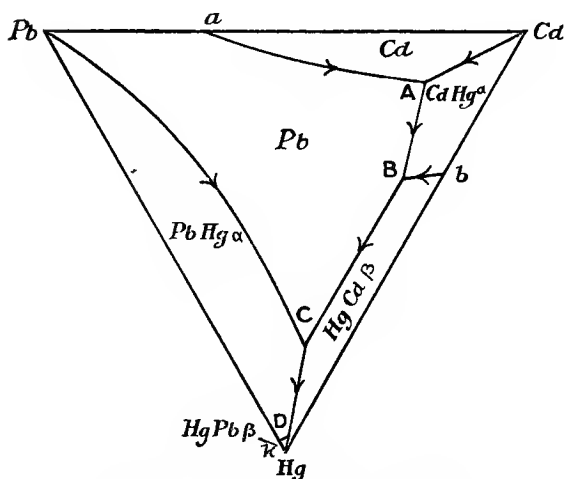
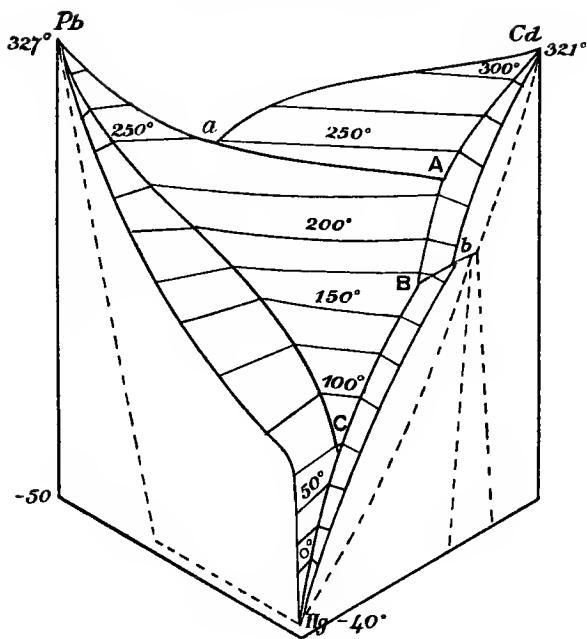

FIG. 33.—Lead, cadmium, and mercury.

simultaneously crystals of Pb and CdHg_a along the line AB. The other lines on the diagram are explained in the same way.

Tammann's method of thermal analysis may also be applied to ternary systems.¹ The experimental difficulties are naturally greater than when dealing with binary systems, and the fact that several arrests may occur on the cooling curve of a single alloy necessitates the use of delicate methods of observation and of a carefully considered scheme for the plotting of the data obtained. It is desirable to make up series of alloys on a systematic plan, choosing their compositions so that each series constitutes a plane vertical section through the space-model; the arrest-times are then plotted for each plane section exactly as for a binary system. Two plans have been adopted by different workers for the arrangement of these sections. Each series may be arranged to contain a constant proportion of one component metal, say A, whilst the relative quantities of B and C are progressively varied. This is equivalent to constructing sections parallel with one of the sides of the triangle of projection. Or, on the other hand, the ratio of B to C in each series may be kept constant, a progressive increase being made in the proportion of A. This is equivalent to constructing sections starting from one angle of the triangle, and diverging. Each method has its advantages. The first is, perhaps, to be preferred, as being the simpler in practice; and if a sufficient number of alloys are taken, it is not difficult, from the data obtained by the first method, to construct plane diagrams in accordance with the second plan, when such are required to emphasize a particular fact, such as the influence of a binary compound on the equilibrium.

As an example of a system which has been studied in this way, we may take the alloys of magnesium, lead, and tin.² One of the three binary systems has been already described (p. 35). The systems Mg—Pb and Mg—Sn resemble one

¹ R. Sahmen and A. von Vegesack, *Zeitsch. physikal. Chem.*, 1907, **59**, 257; 1908, **60**, 507; E. Jänecke, *ibid.*, 1907, **59**, 697. The controversy between these authors deals merely with the possibility or impossibility of the occurrence of certain types of ternary systems amongst alloys.

² A. von Vegesack, *Zeitsch. anorg. Chem.*, 1907, **54**, 367.

another very closely, each containing a binary compound of the same type, solid solutions not being formed to an appreciable extent. As regards the system Pb—Sn, Vegesack, working with somewhat rapid cooling, did not detect the formation of the solid solution which undoubtedly exists; but this error does not noticeably alter the form of the liquidus surface.

The results are shown in Fig. 34, the upper diagram in which represents in elevation the space-model, and the lower the projection of the liquidus on the basal plane. The two compounds, Mg_2Sn and Mg_2Pb , form solid solutions with one another, the solutions forming two series with a small gap, that is, belonging to the Type IV. (p. 53). A vertical section along the line ab therefore represents a binary system of precisely the same type as the cadmium amalgams (p. 55). The width of the gap between the two solid solutions is, however, increased by the addition of lead or tin to the alloy, so that, near the eutectic line hfe the α crystals may be regarded without serious error as pure Mg_2Sn , and the β crystals as pure Mg_2Pb . A section on the line aPb will then show a freezing-point curve corresponding with a simple eutectiferous series, the two components of which are Mg_2Sn and Pb. The arrest corresponding with the eutectic solidification will occur at constant temperature, and will have a maximum duration at the composition f . Fig. 35 represents the sections on ab and aPb respectively, with the arrest time-concentration curves dotted. In the second diagram the atomic percentages of lead only are indicated on the line of abscissæ. Since the starting-point on the left-hand side is the point a , representing the compound Mg_2Sn , the tin and magnesium are in the constant atomic ratio 1 : 2 throughout, and may be calculated with ease.¹

At the ternary eutectic point h (Fig. 34), three solid phases, Sn, Pb, and α crystals (practically pure Mg_2Sn), are in

¹ In the second diagram, the dotted curve is somewhat idealized. Owing to the rapid rate of cooling, Vegesack did not obtain complete equilibrium, and his eutectic line vanished before reaching the limit of the diagram.

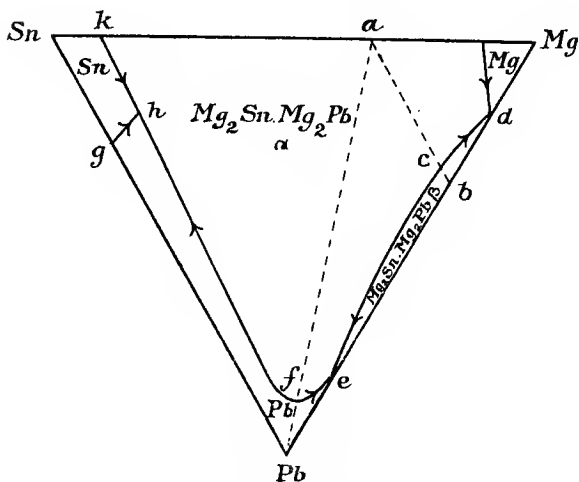
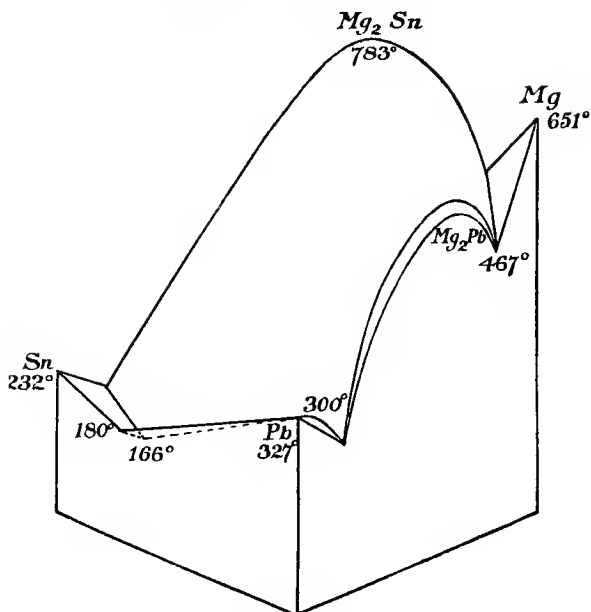

FIG. 34.—Tin, magnesium, and lead.

equilibrium with the liquid. There should be two other invariant points in the ternary system, corresponding with the equilibrium of Mg , α , and β , and with that of α , β , and Pb respectively. These points are, however, found to coincide with the binary eutectic points d and e respectively, thus introducing a certain simplification into the diagram. Only one ternary eutectic mixture is therefore formed.

It will be sufficient to examine the process of solidification

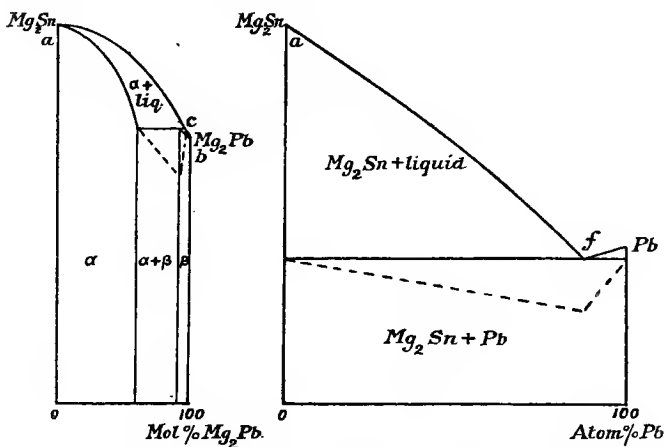
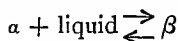

FIG. 35.—Sections through the model (Fig. 34).

in two cases. Consider first a point lying somewhat to the left of the line aPb in the triangular projection (Fig. 34). An alloy of this composition will, on cooling, deposit crystals of the α solution, which will continually adjust their composition to maintain equilibrium with the liquid, until, when the line hf is approached, they consist, as mentioned above, of practically pure Mg_2Sn . When a point on hf is reached, crystals of lead begin to separate, a binary eutectic of lead and Mg_2Sn being thus formed. The temperature continues to fall, as indicated by the arrow-head, until the point h is reached, when the whole of the mother-liquor solidifies at constant temperature as the ternary eutectic.

If, on the other hand, the point representing the composition of the alloy lies between the lines ab and aPb , the first crystals deposited are, as before, the α solution; but the line dce , when intersected, is not a eutectic line, but one of transformation. When it is reached, the α crystals react with the mother-liquor, according to the equation



With the progressive formation of β crystals, the temperature falls towards e , at which a third solid phase appears, namely lead, and the remaining liquid solidifies at constant temperature. The behaviour of any other alloy of the series may be predicted by similar reasoning.

Quaternary systems are represented graphically by means of a regular tetrahedron, of which the four component ternary systems occupy the faces. The methods of constructing such a figure, and of representing the results of thermal analysis in space or on a series of plane sections are discussed by N. Parravano and G. Sirovich,¹ and J. M. Bell.²

¹ *Atti. R. Accad. Lincei*, 1911 [v] 20, ii, 206, 331, 412.

² *J. Physical Chem.*, 1911, 15, 580.

CHAPTER V

THERMAL EQUILIBRIUM OF METALS WHICH ARE ONLY PARTIALLY MISCIBLE IN THE LIQUID STATE

ALL the alloys hitherto considered have been assumed to melt to a homogeneous liquid. This is, however, by no means a universal condition. Whilst many pairs of liquid metals resemble alcohol and water, mixing in all proportions to form a single liquid phase, others behave like water and ether, the mixtures, within certain limits of concentration and temperature, separating into two immiscible liquid phases. All degrees of miscibility, from the practically complete mutual insolubility of water and mercury to complete miscibility, are observed. Amongst metals, certain pairs, such as lead and aluminium, behave, at temperatures only slightly above their melting-points, like mercury and water, separating into two layers, each of which consists of one of the metals in a practically pure state. A more common case is that in which each metal shows a certain limited power of dissolving the other, so that the two liquid layers consist of dilute solution of A in B, and of B in A respectively. Complete immiscibility cannot be said strictly to occur, the apparent instances of such a condition being regarded as cases in which the reciprocal solubility of the two components is very small.

This last statement will be understood after a consideration of the effect of temperature on the equilibrium of partially miscible liquid phases. Whilst the reciprocal solubility of two liquids may either increase or decrease with rise of temperature,¹ only the former case has been observed in alloys, and it

¹ See A. Findlay, *The Phase Rule*, 99.

is, according to our knowledge of the general properties of metals, exceedingly improbable that the reverse condition should ever present itself. As the temperature rises, then, the liquid layer in which A is in excess becomes increasingly richer in B, and conversely, the layer in which B is in excess becomes increasingly richer in A, that is, the compositions of the two layers tend to become more nearly equal. This points to the existence of an upper limit of temperature, at which the two liquid phases would become identical in composition, resulting in the formation of a single homogeneous liquid. Such a *critical solution temperature* probably exists in all cases of partial miscibility, although its experimental realization is a matter of extreme difficulty, owing partly to the fact that many of the metals forming alloys of this type are volatile, so that the boiling-point is reached below the critical temperature, and partly to the difficulty of observing the formation of layers directly, owing to the absence of transparency. For these reasons, the critical phenomena in liquid alloys have been very little studied, although the increase of reciprocal solubility with rising temperature has been noticed in several cases. The few measurements which exist¹ are more or less inaccurate, owing to imperfect separation of the two layers. When the alloys are rapidly cooled and analysed after solidification, time is often afforded for a change in composition to take place, whilst attempts to separate the still liquid alloys by means of a pipette often fail through the tendency of the heavier alloy to remain suspended in globules in the lighter layer.

If we consider two metals, the miscibility of which at a temperature slightly above the melting-point of the less fusible metal is so small as to escape observation, the process of freezing of any mixture of the two will be a very simple one. The freezing-point of each metal will be entirely unaffected by the presence of the other, and will thus be the same, whatever be the composition of the mixture taken. The whole of the

¹ W. Spring and L. Romanoff, *Zeitsch. anorg. Chem.*, 1896, **13**, 29 (lead-zinc and zinc-bismuth, critical temperatures determined); C. R. Alder Wright, *Proc. Roy. Soc.*, 1891, **49**, 156 (bismuth-zinc).

less fusible metal thus crystallizes at its normal freezing-point, after which the temperature falls to the freezing-point of the second metal. This may be represented in a diagram as in Fig. 36, and does not call for further remark.

If the two metals have a distinctly measurable miscibility in the molten state, the diagram will, in the simplest case, take the form shown in Fig. 37. The freezing-point of A will be depressed by the addition of small quantities of B; and con-

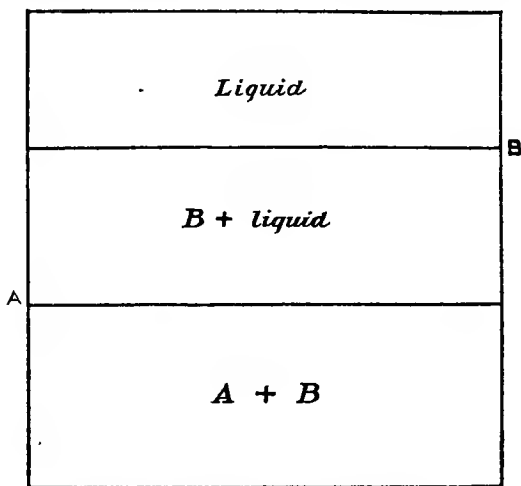

FIG. 36.—Completely immiscible liquids.

versely, that of B will be depressed by the addition of A. The eutectic temperature will probably lie near to the freezing-point of the more fusible metal, as at C; and in fact, in the observed cases of alloys belonging to this type, the eutectic point usually lies so near to the end of the series as to be practically indistinguishable from the freezing-point of the pure metal. Thus, in the alloys of copper and lead (Fig. 38¹), the freezing-point of lead is only lowered to the extent of 1.17° , the eutectic mixture containing only 0.06 per cent. of copper.²

¹ C. T. Heycock and F. H. Neville, *Phil. Trans.*, 1897, 189A, 25.

² *Trans. Chem. Soc.*, 1892, 61, 888.

From Fig. 37, in which the assumption is made that both metals crystallize in a pure state, neither compounds nor solid solutions being formed, it will be seen that liquid alloys rich in B will first deposit crystals of B, the temperature falling as indicated by the curve BE. This continues until the liquid reaches the temperature and concentration represented by the point E, at which the freezing-point curve intersects the miscibility curve, shown as a dotted line. At this point the mother-liquor, if it continued to deposit crystals of B, would attain a

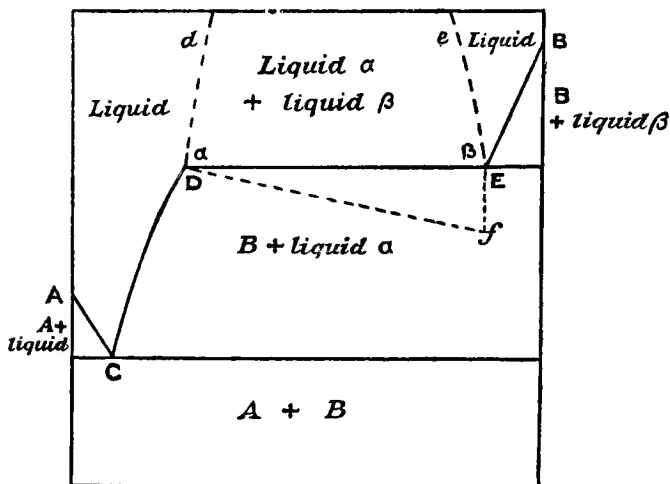

FIG. 37.—Partial miscibility.

composition represented by a point lying somewhere between D and E. The diagram shows, however, that all such points lie within the region of immiscibility, and the result of the crystallization must therefore be the formation of a second liquid phase having the composition of the alloy D. There are thus three phases in contact with one another, namely, the solid metal B and the two liquid phases D and E. The system is consequently invariant, and the further crystallization must take place at constant temperature. This is the meaning of the horizontal line DE. As crystallization proceeds, the

mean composition of the part of alloy remaining liquid is represented by a point travelling along this line from E to D, until D is reached, and the liquid alloy E disappears. There are now only two phases present, and any further withdrawal of heat has the effect of lowering the temperature, the metal B now crystallizing from a homogeneous liquid along the branch DC until the eutectic point C is reached, after which

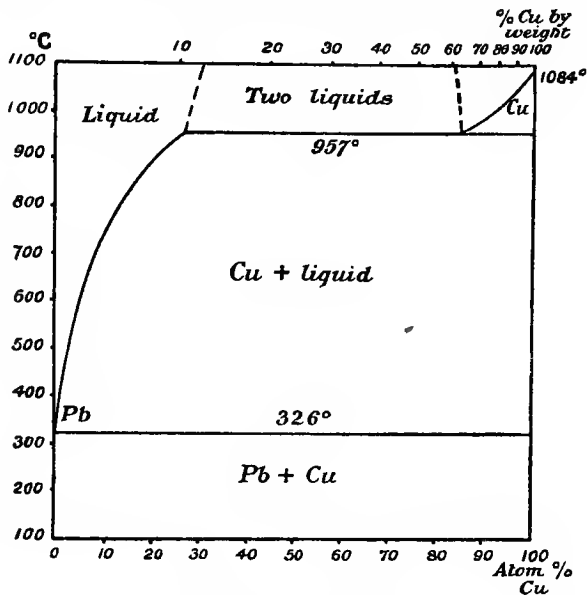

FIG. 38.—Copper and lead.

the process continues in a perfectly normal fashion. On the individual cooling-curves of alloys of this system, the formation of the second liquid phase is marked by a horizontal portion, exactly resembling the arrest due to the solidification of a eutectic. Microscopical examination, however, generally suffices to distinguish the two cases. The maximum duration of this arrest will be shown by the alloy having exactly the composition of E, and the duration will become zero for the alloy having the composition D, as indicated by the curve DfE.

If the liquid alloy has originally a composition between D and E, the separation into two layers takes place before the crystallization of solid metal begins. As crystals of B separate from the liquid alloy E, a larger quantity of the conjugate alloy D is formed, and this process continues until the whole of E has disappeared. The curve of miscibility, Dd_eE , has not been represented as closed, as the maximum, the temperature, that is to say, at which the composition of the two liquid phases becomes identical, is in general so high as to be unrealizable under the conditions of the experiment, and to represent the branches Dd' and Ee' as meeting at a critical point within the limits of the diagram would therefore be misleading. In most of the alloys of this type hitherto observed, also, the branch DC is very steep, so that the amount of the metal B crystallizing during the fall of temperature from that of the horizontal DE to that of the eutectic point is usually very small, and the arrest on the cooling curve is correspondingly difficult to measure.

It is not necessary to enter minutely into the nature of the modifications which it is necessary to make in such a diagram in order to embrace the cases in which either solid solutions or inter-metallic compounds are formed. A comparison of the diagrams already discussed will render the construction of such a complex diagram for any particular case an easy matter. The form of the equilibrium diagrams and arrest curves in such cases has been treated of by Tammann.¹ A single example, the sodium-cadmium series,² is represented in Fig. 39. Two compounds are formed, giving rise to maxima in the freezing-point curve, and there is a small region of partial miscibility between the compound Cd_2Na and sodium. The formula of the second compound is doubtful; it may prove to be Cd_3Na instead of Cd_2Na , as represented in the diagram.

¹ *Zeitsch. anorg. Chem.*, 1905, **47**, 289.

² C. H. Mathewson, *ibid.*, 1906, **50**, 171; N. S. Kurnakoff and A. N. Kusnetzoff, *ibid.*, 1907, **52**, 173.

TERNARY SYSTEMS IN WHICH A REGION OF PARTIAL
MISCIBILITY OCCURS

The formation of immiscible liquid phases assumes its chief practical importance in systems composed of three metals. For the study of such systems, we make use of

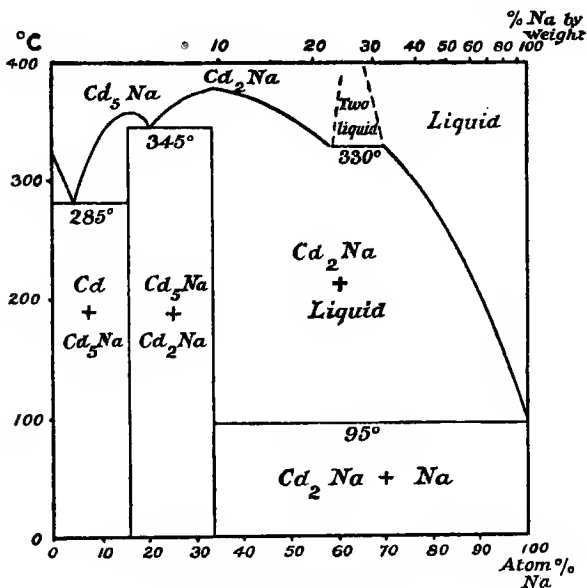

FIG. 39.—Cadmium and sodium.

the triangular diagram already explained and employed in Chapter IV. to express the results of the thermal analysis of ternary systems.

When, to a mixture of two metals, such as molten lead and zinc, a small quantity of a third metal is added, the mutual solubility of the two original metals is changed. For instance, if the added metal is tin, the solubility of lead in zinc, and of zinc in lead, will be increased by the addition, and at the same time both liquid layers will be found to

contain tin. The result is that the two layers approach more nearly to equality of composition as the quantity of tin is increased, until finally a point is reached at which the two liquid alloys become identical, and a single homogeneous liquid phase is formed. If we now construct a triangular diagram showing the composition of the liquid phases at some given temperature, we obtain a result such as that shown in Fig. 40,¹ which represents the results obtained with mixtures of lead, zinc, and tin at 650° . A mixture, the original composition of which is expressed by a point falling within the curved

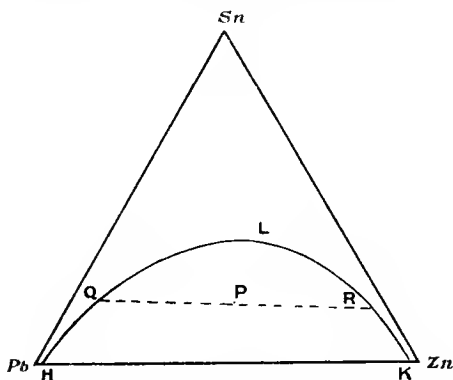

FIG. 40.—Isothermal of tin, lead, and zinc at 650° .

boundary, as at P, separates into two liquid layers, the composition of which at 650° is represented by Q and R respectively. The alloys Q and R are then *conjugate* alloys. The line joining them must pass through P, and was called by Stokes a *tie-line* or *tie*. As the proportion of tin is increased, the ties become shorter, finally vanishing at the point L. At this point the two liquid phases become identical in composition, and the mixture becomes homogeneous. We thus see that all points in the triangle lying outside the curve HQLRK represent homogeneous liquid alloys; whilst points within this curve represent alloys which, at the given temperature, can

¹ C. R. Alder Wright, C. Thompson, and J. T. Leon, *Proc. Roy. Soc.*, 1891, 49, 174.

only exist in the form of two co-existent liquid phases. The curve separating the two regions is the *critical curve*, and points falling within it represent what are termed by Alder Wright *ideal alloys*.

The diagram in Fig. 40 is an isothermal diagram, that is, it represents the state of things at a certain constant temperature, in this case 650° . If we construct similar triangular diagrams for a number of different temperatures, we shall find that the area enclosed by the critical curve diminishes with increase of temperature, in accordance with the increase of mutual solubility of two liquid phases when heated. At a sufficiently high temperature it would vanish entirely, and all mixtures of the three metals, whatever their relative proportions, would form a homogeneous liquid. In the space-model of the ternary system, the *critical surface* will thus be closed above, and the highest point of the surface will evidently be the critical point of the binary system which yields immiscible liquid phases, in this case lead-zinc. So far, no such case has been experimentally studied among alloys.¹

In accordance with the doctrine of phases, the composition of two conjugate alloys should be independent of their relative quantity. Consequently, if we take equal weights of mixtures containing lead and zinc in the proportions 2 : 1, 1 : 1, and 1 : 2 respectively, and add the same quantity of tin to each mixture, we should obtain liquid layers having the same composition in each case, and only differing in their relative quantity. This was shown by Stokes, in the paper referred to, to be a necessary consequence of the principle of equilibrium involved. The results of Wright, Thompson, and Leon show that this result is not fully realized in practice. The reason lies in the experimental difficulties of the investigation. Very thorough stirring is necessary in order that the two liquid layers may come into contact sufficiently to ensure equilibrium, especially when, as in the case of lead and zinc, the two liquid

¹ For the graphical representation of such a system, with examples from organic mixtures, see P. A. Meerburg, *Zeitsch. physikal. Chem.*, 1902, 40, 641.

metals differ widely in density. Further, when equilibrium has once been attained at a definite temperature, and sufficient time has been allowed to elapse for complete separation of the two layers to take place, the withdrawal of samples of those layers for analysis presents some difficulty, since, as the alloy cools, a readjustment of the equilibrium takes place. In the investigations mentioned above, the alloys were cooled rapidly, samples being taken from the solidified upper and lower layers after complete cooling, it being assumed that no marked change of composition had taken place in the short period of cooling. It is probable that this assumption is not justified,¹ and in future investigations it is desirable that samples should be taken at the temperature of the experiment by means of suitable pipettes.² A method which is perhaps simpler in its application consists in the employment of a special furnace, which allows samples of the contents to be withdrawn by tapping at different levels.³

An equilibrium of this kind may be looked at from another point of view. We may require to consider, instead of the influence of a third metal in altering the mutual solubilities of two others, the proportion in which the third metal is distributed between the two others: In the case already mentioned, tin dissolves in both the lead layer and the zinc layer. The ratio of the concentrations of tin in the upper and the lower layer may be called the *partition-coefficient* of tin between lead and zinc. The concentration of tin in the two liquid phases is not usually the same, and the tie-lines are therefore not, in general, parallel to the base of the triangle; the critical curve is consequently more or less asymmetrical. The experimental data at present available are very scanty, and are quite insufficient to allow us to calculate the partition-coefficient with any approach to accuracy. The coefficient will be affected by the formation of compounds between the added metal and either of the original, partially miscible metals.

An interesting case of this kind, which has been studied in

¹ W. D. Bancroft, *J. Physical Chem.*, 1899, **3**, 217.

² G. N. Potdar, *J. Coll. Sci. Tōkyō*, 1908, **25**, ix.

³ K. Friedrich, *Metallurgie*, 1906, **3**, 396.

detail on account of its technical importance, is presented by the alloys of lead, zinc, and silver. Silver mixes in all proportions in the liquid state with either lead or zinc, forming compounds, however, with the latter,¹ whilst yielding only a simple eutectiferous series with the former (p. 31). In the ternary system, the distribution is very unequal, the silver passing almost completely into the zinc at temperatures not far above the melting-point. Thus, at 540°, the partition-coefficient is about 300, and is fairly independent of the concentration.² This fact is the basis of Parkes's process for the desilverization of lead, which was first devised by Karsten in 1842, but only brought into practical use some years later. The argentiferous lead is melted, and small quantities of zinc are added and thoroughly mixed by stirring. When cooled to the freezing-point of the layer rich in zinc, a solid scum separates, and, being lighter than lead, accumulates at the surface, and is readily removed. The silver-content of the residual lead may be reduced in this way to 0.0003 per cent., whilst the upper layer contains as much as 25 per cent. of silver. This indicates a very high partition-coefficient near 400°.

As an example of a ternary system which has been more fully worked out, we may take the alloys of silver, lead and copper.³ The space-model is illustrated in elevation and in projection on the base in Fig. 41, the divisions of which represent atomic percentages. The diagrams of the three binary systems have been given previously (silver-lead, Fig. 8; silver-copper, Fig. 23; copper-lead, Fig. 38). The freezing-point surface of the ternary system is seen in the lower part of the figure to be made up of three surfaces, one of which, however, representing the separation of pure lead, is of very

¹ G. J. Petrenko, *Zeitsch. anorg. Chem.*, 1906, **48**, 347.

² G. N. Potdar, *J. Coll. Sci. Tōkyō*, 1908, **25**, ix. Earlier measurements were made by C. R. Alder Wright and C. Thompson, *Proc. Roy. Soc.*, 1890, **48**, 25. Potdar's results indicate a much higher coefficient than those of Wright and Thompson. The equilibrium diagram of the ternary system has been determined by R. Kremann and F. Hofmeier, *Monatsh.*, 1911, **32**, 563, 597.

³ K. Friedrich and A. Leroux, *Metallurgie*, 1907, **4**, 293.

small area compared with the two others. The crystals separating on the surface I. consist of a solid solution of silver in copper. The alloys within the small area bounded by a dotted line in the neighbourhood of Cu have a second arrest during cooling, due to the separation of the mother-liquor into two layers, and consequent crystallization of copper-silver crystals at a constant temperature. The fact that the dotted curve extends so little into the triangle is a proof that the presence of silver greatly increases the miscibility of copper and lead. Within the area I. many of the alloys must begin their crystallization at a constant temperature, owing to the formation of two liquid layers, but it was not determined how far this extends into the triangle. Marked liquation was observed in many of the alloys after cooling.

The solid solution II. contains silver with both copper and lead. The dotted curve in the neighbourhood of Ag represents the approximate limit of saturation of this solution. The line DE is the boundary between the solid phases I. and II., and along it the binary eutectic separates. The third area, FEGPb, is that of crystallization of lead. It is separated from the areas of I. and II. respectively by the binary eutectic lines FE and EG, meeting in the ternary eutectic point E, the co-ordinates of which are

$$\left. \begin{array}{l} \text{Ag } 3\cdot8 \\ \text{Cu } 1\cdot6 \\ \text{Pb } 94\cdot6 \end{array} \right\} \text{ atomic per cent. } \text{Temp.} = 302\cdot5^{\circ}$$

The form of the diagram therefore resembles that of the lead-tin-bismuth series in having three slooping eutectic valleys meeting at a ternary eutectic point, only in this example the point of intersection lies very near to the angle of the triangle.

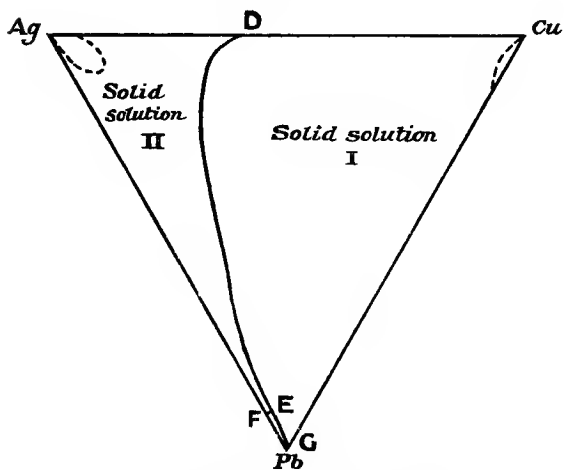
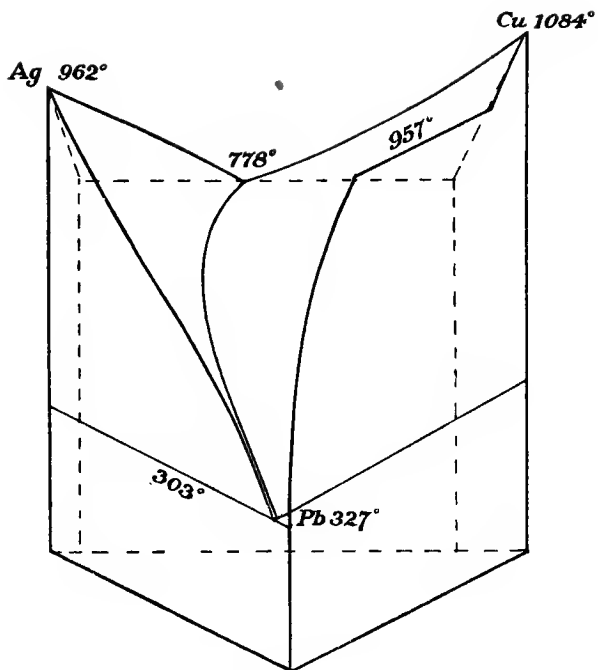

FIG. 41.—Silver, copper, and lead.

CHAPTER VI

PRACTICAL PYROMETRY AND THERMAL ANALYSIS

THE apparatus required for the practical conduct of a thermal analysis comprises (1) a means of heating and cooling the alloy under examination, and (2) a means of measuring the temperature of the alloy from time to time. Both these requirements may be met in a great variety of ways, many types of furnaces, and also of pyrometers, having been designed and employed in investigations of this kind. Only such forms will be described here as have shown their utility in practice.

FURNACES

A furnace intended for use in metallographic work must fulfil certain conditions, which greatly restrict the number of suitable types. The most important of these conditions are—

1. The distribution of temperature in the interior of the furnace must be sufficiently uniform to ensure that all parts of the specimen under examination are sensibly equal in temperature.

2. The temperature of the interior must be capable of continuous variation throughout a considerable range, and it must be possible to make the rate of cooling (or in certain cases of heating) so slow that time is allowed for the attainment of sensible equilibrium in the alloy.

3. It should be possible to heat the alloy out of contact with gases capable of acting on it chemically or of dissolving in it to a notable extent.

Gas and electric current are the only sources of heat which

are sufficiently under the control of the experimenter to come into consideration for such a purpose. When larger quantities of alloys have to be prepared, however, it is more convenient and economical to heat the crucible in a wind furnace fed with coke, the product being either poured in a molten state into smaller crucibles, or cast into ingots, which are subsequently divided by sawing or breaking.

A gas furnace for metallography should be heated by means of Bunsen burners, the horizontal burners with gauze or grid generally proving unsatisfactory after they have been in use for some time. A large, solid flame of uniform temperature is desirable, and this is only given by the best forms of Bunsen burner. The most suitable burner for the purpose, especially when a temperature as high as the melting-point of copper is required, is the Méker burner, shown in Fig. 42. The burner is of brass, with very large holes for the admission of air, so that the air supply is sufficient for complete combustion. Firing back is prevented by a deep nickel grid, the openings of which form a series of tubes 2 mm. square and 10 mm. deep. The large solid flame is of practically uniform temperature throughout, there being no inner cone of cooler gases as in the ordinary Bunsen flame. The furnace shown is intended for melting small quantities, it being possible to melt copper in a short time. Cooling is too rapid for the taking of satisfactory cooling curves, and further provision against excessive loss of heat by radiation must be made. The simplest contrivance for this purpose is composed of two concentric cylinders of asbestos card, surrounding the burner and crucible, the space between the two cylinders being filled with fine sand or magnesia. A lid, made of several thicknesses of asbestos card, and provided with a central hole

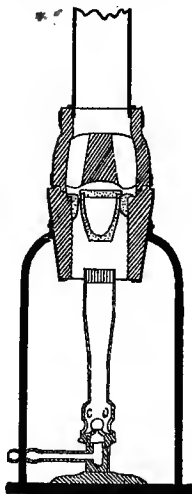

FIG. 42. — Méker crucible furnace.

for the passage of the thermo-couple, is placed over the cylinder as soon as the alloy is melted. Such a simple arrangement is quite satisfactory when a determination of the freezing-point is all that is required. For higher temperatures the Fletcher concentric jet furnaces may be used, the blast being supplied by a rotatory blower.

The additional convenience afforded by electric furnaces is, however, so great that this form is to be preferred wherever electric current is available. Of the types of electric furnace which occur in commerce, neither the arc nor the induction furnace is suitable for metallographic work, and the forms of apparatus to be described all depend on the heating effect of a current passing through a resistance. The resistance employed may be—

1. A helix of metallic wire or foil, wound on a non-conducting tube ;
2. A tube of conducting material, through which a heavy current of low voltage is short-circuited ;
3. A mass of granulated material of comparatively low conductivity, loosely packed between terminal blocks of metal or carbon.
4. A rigid helix of conducting carbon.

The majority of laboratory furnaces are of the first type. In the older patterns, a helix of platinum wire was wound on a porcelain tube. This had the disadvantage that the wire, if thin enough to use current at the ordinary voltage, quickly burnt out, whilst at high temperatures the porcelain was liable to disintegrate and crack, owing to the very local character of the heating. This difficulty is overcome in the Heraeus furnace by using a ribbon of thin platinum foil in place of wire. The temperature of the foil is never greatly different from that of the tube, and local overheating is avoided. The helix should be wound so closely that adjacent turns are separated by the shortest possible distance, and they are kept in place by an asbestos ribbon. The tube and foil are enclosed in a thick insulating layer of magnesia, and an outer casing of asbestos bound together by metal bands. The external appearance of such a furnace, adapted for use in a horizontal or vertical

position, is shown in Fig. 43. When used vertically, the crucible is supported at a suitable height on a column of porcelain or fireclay, a cap being placed over the top of the tube to hinder the production of air-currents. When used horizontally, as in annealing, it is desirable to close the ends with mica windows.

A platinum resistance furnace of this type may be heated for a short time to $1300-1400^{\circ}$. Continued heating at the

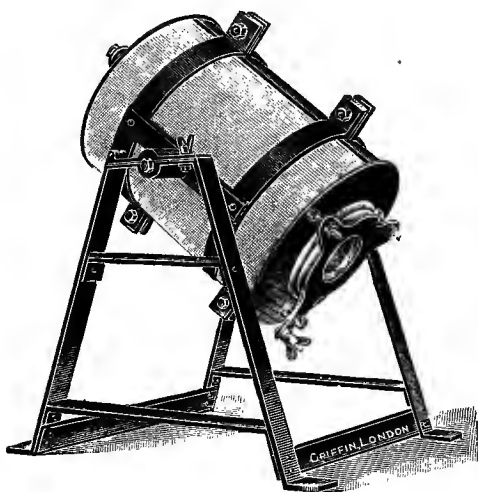

FIG. 43.—Platinum resistance furnace.

latter temperature causes destruction of the tube; it is therefore inadvisable to use this pattern of furnace for temperatures above 1200° . Tubes of alundum, prepared from pure alumina, are very suitable for high temperatures. For lower temperatures, fused silica tubes may be used instead of porcelain, but silica becomes a conductor at about 1000° . A variable resistance should be used in series with the furnace, and the life of the heating tube and helix is considerably prolonged if care is taken to raise the temperature gradually. An ampèremeter is generally inserted in the circuit for convenience in

regulating the current. On a 220-volt supply, a furnace of this kind requires from 6 to 14 ampères, according to the temperature.

For alloys of fairly low melting-point, and for annealing purposes, it is possible to work with a less expensive heating material than platinum. Nickel wire, wound on unglazed porcelain and packed in quartz, has been found useful up to 1000°.¹ Nickel wire, however, gradually disintegrates in use, owing to the escape of dissolved gases.² Much better results are obtained with an alloy of nickel "nichrome," which has the further advantage of a very low temperature-coefficient.

The second type of furnace, in which the resistance is formed by a tube enclosing the heating-space, is mainly employed for very high temperatures, above those at which the ordinary pattern of furnace can be used. It has the disadvantage that it cannot be worked by means of the ordinary supply of current, but requires a transformer. Two materials have been employed for the construction of the tubes, namely, carbon and iridium. Of these, iridium has the drawbacks of high cost and volatility. With an iridium tube 120 mm. long, 19.7 mm. in diameter, and 0.4 mm. thick, protected by a fireclay cylinder, the temperature may be raised to 1600° in 30 seconds, using a current of 900–1000 ampères at 3 volts.³

Carbon tubes, which may be employed instead of the costly iridium, have the disadvantage of forming carbon monoxide in contact with air, which it is practically impossible to exclude. This gas may in some instances affect the results seriously, as it is readily dissolved by many metals. The risk is minimized by the passage of a current of nitrogen during the experiment.

A somewhat original modification of the tube resistance

¹ J. Harker, *Phil. Trans.*, 1904, 203A, 343.

² H. C. H. Carpenter, *Coll. Researches Nat. Phys. Lab.*, 1908, 3, 259.

³ K. Friedrich, *Metallurgie*, 1908, 5, 703, see also W. C. Heraeus, *Zeitsch. angew. Chem.*, 1905, 18, 49.

furnace was designed and employed in work at very high temperatures, exceeding the melting-point of platinum.¹ The tube in this apparatus was constructed of the Nernst mass used in electrolytic filament lamps, composed of a mixture of rare earths. Such a mass, whilst non-conducting at the ordinary temperature, conducts electricity when raised to a red heat, the conductivity then increasing as the temperature rises. A metallic balancing resistance is therefore necessary. The heating tube is enclosed in an outer tube of porcelain or fire-clay which serves as a support, the intervening space being packed with pure zirconia. The porcelain tube is wound externally with nickel wire, by means of which the preliminary heating is effected.

In the third type of furnace, the resisting material has a granular form. The substance employed may be carbon or a mixture of carbon, carborundum, and silicates.² A furnace of this kind, for use at temperatures of 800–1000°, is illustrated in Fig. 44.³ The material is packed in a cylindrical space between the two concentric fireclay cylinders *a* and *b*, current being led in by carbon poles through the two spaces *c* and *d*, filled with granules. These chambers are so wide that the temperature is not greatly raised. *f* is the crucible. The cylinders *a* and *b*, and the fireclay wedge *g*, are removable, as they are liable to crack in repeated use. In the pattern shown, there is also a channel, packed with granules, in the removable lid, in order to maintain a uniform temperature. The lid is furnished with an opening, *k*, for the passage of the thermocouple. Such a furnace may be used on a 220-volt circuit. The same author describes (*loc. cit.*) a furnace for high temperatures (1500°), in which the heating space is a narrow channel in a mass of Meissen fire-resisting material.

Granular resistances have the marked disadvantage that inequalities in the packing are difficult to avoid, leading to

¹ J. A. Harker, *Proc. Roy. Soc.*, 1905, 76A, 235.

² A. Buss, *Zeitsch. angew. Chem.*, 1905, 18, 239.

³ K. Friedrich, *Metallurgie*, 1907, 4, 778. See also F. Mattonet, *Metallurgie*, 1908, 5, 186; Deckert, *ibid.*, 638.

local inequalities of temperature, which often result in the cracking of crucibles, etc. At high temperatures arcs are liable to form between granules which are not in contact. After repeated use, also, the granular material shakes down into closer packing, with the result that the temperature attainable falls. These furnaces have found greater favour on the Continent than in this country. The efficiency of

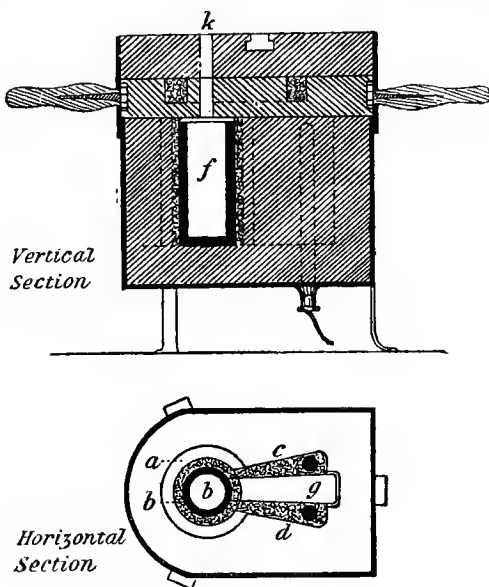

FIG. 44.—Furnace for granular heating material.

this type has been systematically examined by H. Harkort,¹ who finds that granulated carbon may be used in place of complex material, and that the finer the granulation, the higher the resistance. The furnace found by him to give the best results up to 1700° has the construction shown in Fig. 45. The carbon is packed between two carbon blocks, *a, a*, in a cylindrical space formed by the hard fireclay cylinder *b* and

¹ *Metallurgie*, 1907, 4, 617.

the mass of compressed kaolin *c*. The outer packing is composed of kieselguhr, held in place by an iron casing. The carbon blocks are only in contact with the granulated carbon for the lower half of their length, the upper part being embedded in kaolin. The carbon packing is continued above this point, in order to form a reducing layer, at a lower temperature than the main mass. A double fireclay lid is used. The consumption of current is about 70 ampères on a 110-volt circuit.

Whatever construction of furnace be adopted, precautions must be taken against loss of heat by conduction and radiation. The furnace should be enclosed in an outer non-conducting double casing, which may be conveniently built up of asbestos card, the space being filled with magnesia or kieselguhr. The plan has also been adopted of enclosing the whole furnace in a large water jacket, in order to eliminate irregularities in the temperature of the environment.¹

In taking a cooling curve, it is usual to shut off the current when the alloy has reached a temperature sufficiently above its melting-point, and then to allow cooling to take place by radiation. This method has been modified in some recent work on fused salts,² and there are some advantages to be

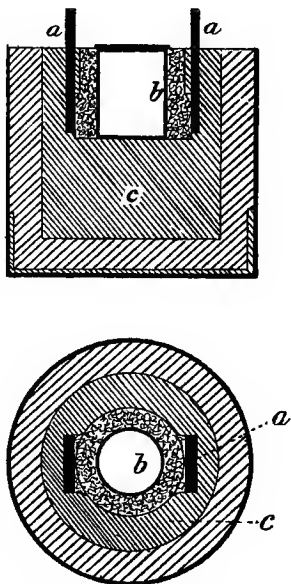

FIG. 45.—Granular carbon furnace.

¹ W. Rosenhain, *J. Inst. Metals*, 1909, 1, 245.

² W. Plato, *Zeitsch. physikal. Chem.*, 1906, 55, 721. A similar arrangement, liquid resistances being used to reduce the current, has been employed by A. Portevin, *Rev. de Métallurgie*, 1908, 5, 295.

anticipated from an application of the improved method to metallography. Instead of stopping the supply of current instantly, Plato adopts the plan of reducing the current in a continuous manner from the maximum value to zero. A Heraeus furnace is used in a vertical position, the crucible being supported on a vertical porcelain column. The current, obtained from a battery of accumulators giving a tension of 220 volts, passes through a resistance consisting of a nickel wire wound on a porcelain cylinder, the other contact being a spring pressing on the wire. The cylinder is slowly rotated by means of a geared motor, and the resistance of the circuit is thus gradually increased at any desired rate, producing a gradual and regular diminution of the temperature of the furnace. A cooling curve taken in such a furnace is practically a straight line so long as no change involving the development of heat takes place. The portion of the curve representing the cooling of the liquid is also practically in a line with that representing the cooling of the solid, and the change in rate of cooling brought about by freezing is thus particularly well marked, a fact which is of importance when dealing with the theoretical interpretation of the curves (see p. 124).

Provision should always be made, by means of fireclay or porcelain plugs with inlet and outlet tubes, for the passage of a current of gas during melting and cooling, in order to prevent oxidation. Nitrogen is the most generally suitable gas for this purpose, but if taken from a cylinder, it should be passed through a vessel containing sticks of phosphorus, or through a tube containing heated copper, in order to remove the oxygen which is always present. The use of nitrogen is, of course, excluded when metals capable of forming nitrides, such as magnesium, are present. Hydrogen may also be used, and, in certain cases, carbon dioxide. The last-named gas is decomposed by magnesium. The current of gas is led in by a tube of Jena glass or Marquardt porcelain, according to the temperature required, the tube terminating just above the level of the alloy. Volatile metals, such as zinc, arsenic, or cadmium, may pass through the porcelain walls of a furnace in the form

of vapour, and may attack the platinum used as a heating material. Manganese is particularly difficult to deal with at high temperatures for this reason, as its vapour readily passes through a wall of Marquardt porcelain.¹ It is necessary therefore to shield the porcelain by means of an inner iron tube wrapped with asbestos.

It is of great advantage to have a ready means of heating and melting alloys in a vacuum, since no gas is absolutely undissolved by molten metals. An electric vacuum furnace has been successfully employed in the investigation of electrolytic iron, from which it was necessary to remove occluded gases.² This furnace is illustrated in Fig. 46. The heating device is a carbon helix, constructed by cutting a helical slit in a tube of hard carbon, 300 mm. long and 40 mm. internal diameter, the thickness of the tube being 6.5 mm. and the width of each turn 11 mm. This helix stands in a wider carbon tube, from which it is insulated by porcelain collars. Both tubes fit into a brass cylindrical vessel, to which glass flanged ends are luted, the current being led in by wires passing through glass side arms. The crucible is supported on a carbon tube, carried by an iron rod. The brass vessel can be exhausted, and is contained in an outer metallic vessel serving as a water-jacket.³

¹ F. Wüst, *Metallurgie*, 1909, 6, 3.

² A. Müller, *Metallurgie*, 1909, 6, 145. A simpler form of this furnace was used by P. Oberhoffer (*ibid.*, 1907, 4, 427), in an investigation of the specific heat of iron.

³ Other forms of vacuum furnace are described by W. J. Forsythe, *Astrophys. J.*, 1911, 34, 353; and by J. C. W. Humfrey, *Iron and Steel Carnegie Schol. Mem.*, 1912, 4, 80; the latter being a very simple form.

CRUCIBLES

For work at moderate temperatures, either fireclay or plumbago crucibles may be conveniently used, the latter consisting of a mixture of graphite and fireclay, which resists changes of temperature, and is free from porosity. Jena glass

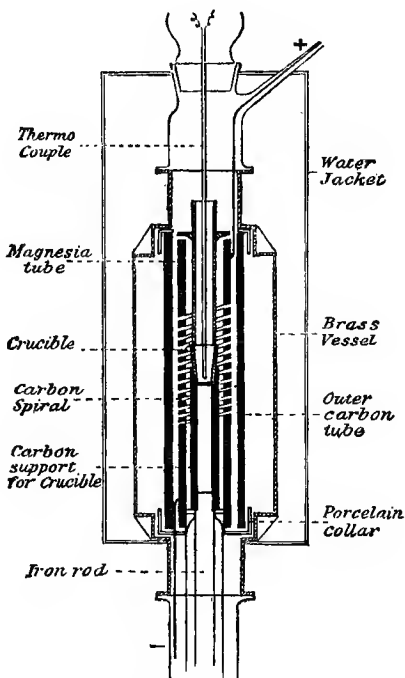

FIG. 46.—Electric vacuum furnace with carbon spiral.

tubes have been used extensively by some workers, and are convenient when working with amalgams. They are, however, necessarily of small capacity, and it must be emphasized that cooling curves, taken with a quantity of only 10 grams or so

of alloy, are worthless for the construction of the thermal diagram. A quantity of at least 100 grams is required in order that trustworthy results may be obtained, and crucibles of this capacity should be used as far as possible. Fireclay cannot be used at very high temperatures on account of its softening, and it is further readily attacked by the layers of slag formed by the oxidation of many metals, especially lead and manganese, whilst the presence of reducing metals, such as aluminium or calcium, in the alloy to be melted, leads to the reduction of silicates, and the introduction of silicon as an impurity into the alloy. Carbon crucibles, turned from a block of artificial graphite, are often very convenient. Carbon is, however, taken up by metals of the iron group, whilst the presence of oxygen, which cannot be completely excluded from ordinary furnaces, leads to the formation of carbon monoxide, which is dissolved by many molten metals.

Hard porcelain, as made at the Berlin or Meissen works, is a very useful material. Like fireclay, it is attacked by those metals and slags which act chemically on silicates. Magnesia crucibles, made from magnesia fired at a very high temperature, are perhaps the most generally applicable to alloys of high melting-point. They are somewhat fragile, and require careful handling when hot. They are, moreover, porous to certain metals, copper passing through them quite readily.

A fireclay or plumbago crucible may be made more resistant by brasquing, that is, by lining with a more resistant material. Graphite or retort carbon, mixed to a stiff paste with sugar syrup or tar, makes a good carbon lining; whilst fused and ground magnesia, mixed with a little magnesium chloride solution, may be used as a lining for many purposes.

The Berlin Porcelain Manufactory now manufactures crucibles of spinell mass ($2\text{MgO}, \text{Al}_2\text{O}_3$), which is impervious to carbon monoxide, and may be heated safely to 1700° . Alumina, especially in the pure form known as alundum, has also been used as a material for crucibles. Like magnesia, alundum is highly porous. Carborundum and other materials, including the very resistant pure zirconia, have been tried in

technical practice but have not yet come into general use in laboratories.¹

When an indifferent atmosphere is not employed, and air is admitted to the furnace, it is generally necessary to cover the surface of the alloy with a protecting layer. Pure sugar charcoal or wood charcoal may be used at low temperatures, graphite at very high temperatures. Carbon will not, however, protect zinc or magnesium from oxidation, and its presence must be avoided when metals capable of combining with it, such as iron or nickel, are being melted. The following salts are suitable for use as a protecting layer: borax (m.-p. 741°), sodium chloride (m.-p. 820° , volatile at its melting-point), anhydrous carnallite ($\text{KCl}, \text{MgCl}_2$, m.p. c. 450°), potassium cyanide (m.-p. 622°), barium chloride (m.-p. 960°).

PREPARATION OF ALLOYS

Alloys are generally prepared by fusing together their components. When these are readily fusible, the operation presents no difficulty, as it is sufficient to introduce the weighed metals into a crucible and to heat until molten, when the mass is thoroughly stirred to ensure complete admixture. It is not possible to alloy metals of very different melting-points in this way. If zinc and copper are heated together, the zinc is mostly lost by volatilization and oxidation before the melting-point of the copper is reached. In such a case the copper should be melted first, and the zinc added to it. The zinc should be in coarse pieces, and should be immediately pushed under the surface of the copper, the mass being stirred with a fireclay or carbon rod after each addition. As the first fragments of zinc are added, the high temperature of the molten copper causes some volatilization of zinc, and a white flame is produced, white flakes of zinc oxide being formed. As the temperature of the alloy is lowered by successive additions of zinc, the

¹ The properties of heat-resisting materials intended for exposure to high temperatures have been studied by L. Baraduc-Muller, *Rev. de Métallurgie*, 1909, 6, 700; S. Wologdine, *ibid.*, 767.

“flaring” becomes less marked. The loss of zinc, amounting to about 2 per cent. when making up an alloy of 60 per cent. Cu and 40 per cent. Zn on a small scale, must be allowed for in weighing out the quantities of metal to be used.

Aluminium should be added in the same way as zinc, as if melted alone it becomes covered with a thin, but very tenacious, layer of aluminium oxide, which coats any solid metal on its introduction and thus prevents alloying. When aluminium is added to molten copper, a great rise in temperature is observed, the alloy often becoming white-hot, in spite of the cooling due to the introduction of the cold metal. This is not due, as was once supposed, to the heat of combination of copper and aluminium, but to combination of a part of the aluminium with the oxygen which is always present in commercial copper, and a further quantity of which is absorbed from the air by the copper during melting. This activity of aluminium in removing oxygen from copper is often made use of in preparing copper alloys. The presence of oxygen in these alloys is undesirable, as the metals added form oxides which remain entangled in the molten mass, diminish its fluidity, and cause heterogeneity in the ingot.¹ The addition of aluminium brings about the reduction of other oxides, and the formation of aluminium oxide, which separates from the alloy with greater facility. Magnesium is used in a similar manner. Phosphorus and silicon, which are excellent deoxidizers, are commonly added in the form of alloys with copper or some other constituent of the alloy to be prepared. Thus phosphorus is added in the form of 10 per cent. phosphor-copper, a commercial product, 1 per cent. of which, equivalent to 0.1 per cent. of phosphorus, is usually sufficient to deoxidize copper under ordinary conditions. The quantity added should be sufficient to remove the whole of the oxygen, leaving none, or at most a trace, of the deoxidizer in the final product. Iron and its alloys are frequently deoxidized with ferro-silicon.

¹ E. Heyn and O. Bauer, *Zeitsch. anorg. Chem.*, 1905, 45, 52, have investigated the influence of oxygen on the alloys of copper and tin. The stannic oxide crystals formed separate with difficulty from the molten alloys.

Alloys with arsenic are troublesome to prepare, on account of the great volatility of this element, but by employing an electric furnace with carbon tube resistance, and heating very rapidly to a high temperature, alloys with platinum containing from 2.7 to 28.3 per cent. of arsenic have been prepared.¹ It is generally preferable to make a rich alloy of the metal in question with arsenic, and to dilute this by melting with successive larger quantities of the second component. It is rarely possible to examine the entire series up to arsenic, as the richer alloys dissociate when heated under atmospheric pressure. The rich alloy is conveniently prepared by heating the oxide of the metal with a considerable excess of arsenic. This plan has been adopted in studying the alloys of arsenic with nickel² and with cobalt.³

The preparation of a rich alloy, which is subsequently melted with further quantities of one of its components, is a convenient means of avoiding loss by oxidation and burning, as the dilution with the second metal commonly takes place by quiet fusion. Rich alloys of aluminium or zinc with copper may be prepared and analysed, and by adding the calculated quantity of copper other alloys of the series may be accurately prepared. A ternary alloy of copper, nickel, and zinc, known as German silver, is thus prepared by melting together alloys of copper and nickel, and copper and zinc.

Metal.	Boiling-point.	Metal.	Boiling-point.
Mercury . . .	357°	Aluminium . .	1800°
Cadmium . . .	780°	Manganese . . .	1900°
Zinc	920°	Silver	1955°
Magnesium . .	1120°	Chromium . . .	2200°
Bismuth	1420°	Tin	2270°
Antimony . . .	1440°	Copper	2310°
Lead	1525°	Iron	2450°

The relative volatility of some of the principal metals may

¹ K. Friedrich and A. Leroux, *Metallurgie*, 1908, 5, 148.

² K. Friedrich and F. Bennigson, *ibid.*, 1907, 4, 200.

³ K. Friedrich, *ibid.*, 1908, 5, 150.

be seen in the table on p. 108, which gives the boiling-points under atmospheric pressure.¹

Arsenic sublimes without melting. Its sublimation temperature under atmospheric pressure is in the neighbourhood of 450° .

The metals iron, chromium, manganese, tungsten, molybdenum, vanadium, etc., and their alloys, if prepared by reduction in the laboratory, form powders which it is difficult to fuse together into a coherent mass. Reduction by the electric arc yields massive metals and alloys, but these always contain considerable quantities of carbon derived from the electrodes. Commercial ferro-silicon and ferro-manganese contain carbon for this reason, and their use in preparing alloys necessarily results in the introduction of this element, the presence of which modifies the equilibrium considerably. The great reducing power of aluminium at high temperatures has been utilized in what is known as the Thermit process to produce metals and alloys free from carbon.² The metallic oxide, or mixture of oxides if an alloy is to be prepared, is ground and mixed with the necessary quantity of aluminium for complete reduction and introduced into a crucible. The reduction proceeds with great development of heat, and it is only necessary to produce a local elevation of temperature to initiate the reaction. This is accomplished by means of a small quantity of a mixture of fine aluminium powder and barium peroxide, which is placed in a heap on the surface of the thermit mixture, and ignited with a piece of magnesium ribbon or of thread impregnated with potassium nitrate. The reaction begins immediately, and propagates itself very rapidly through the mass, so that a few seconds suffice to bring the whole contents of the crucible to a white-hot molten state. The metal or alloy may be poured into a mould, the liquid slag, which consists of fused alumina, being collected separately. The products usually contain some aluminium, but a high degree of purity may be attained. Alloys of aluminium are

¹ The values for the less volatile metals were obtained by means of an optical pyrometer; H. C. Greenwood, *Proc. Roy. Soc.*, 1909, 82A, 396.

² H. Goldschmidt, *Annalen*, 1898, 301, 19; *Physikal. Zeitsch.*, 1902, 4, 166.

readily prepared by employing an excess of the reducing metal. Alloys containing copper and other more fusible metals may also be prepared; but the reaction in such cases is violent and even explosive, owing to the evolution of metallic vapour, so that the reacting substances should be mixed with alumina or other inert material.

Calcium, silicon, and magnesium have also been employed in the thermit reaction, but can only find application in exceptional cases.¹

The metallographist often has occasion to prepare castings of alloys for the purpose of examining their physical properties. Cast-iron moulds, divided longitudinally and held together by a clamp, are useful for this purpose. The inner surfaces should be rubbed with graphite and the mould warmed before use. Simple sand moulds are easily prepared, a smooth wooden rod being used as the pattern around which the moulding sand is rammed. A sufficient head of metal must be allowed, so that gas bubbles, etc., will collect in the upper part of the rod, which is cut off and rejected. A short length at the lower end should also be rejected, as it is liable to contain sand swept down by the first rush of metal into the mould. To guard against errors due to segregation in the ingot, a small piece should be cut from the upper and also from the lower end of the rod for microscopical examination and chemical analysis.

Although alloys are generally prepared by fusion, there are many other ways in which they may be produced. The "cementation" of iron, its conversion into steel by heating in solid carbon or carbonaceous matter, or in carburizing gases, will receive consideration in dealing with the process of diffusion. A similar process may be applied to other metals. Thus iron and copper may be coated with zinc by heating in zinc dust at a temperature of only 200°,² a true alloy being produced at the surface. The electrolytic deposition of metals from mixed electrolytes also results in the production of

¹ F. M. Perkin, *Trans. Faraday Soc.*, 1907, 3, 115; F. M. Perkin and L. Pratt, *ibid.*, 179.

² S. Cowper-Coles, *Electro-Chemist and Metallurgist*, 1903, 3, 828.

alloys,¹ and this process finds technical application. Amalgams may be prepared by the electrolysis of a salt of the required metal, using a mercury cathode. A continuously acting apparatus has been devised for this purpose.²

PYROMETERS

Of the many types of instrument employed for the measurement of temperature, very few are suitable for the accurate determination of freezing- and transformation-points in metallography. Mercurial thermometers are only available for those amalgams which are liquid at or near the ordinary temperature, and perhaps for isolated experiments on fusible alloys melting at or near 100°. They are not suitable for the determination of transition points, on account of the difficulty of making perfect contact between the bulb and the specimen under examination. Thermometers having the stem above the mercury column filled with nitrogen or carbon dioxide under pressure, are obtainable with graduations up to 450°; their employment at such temperatures, however, is very unsatisfactory, owing to the uncertain character of the permanent deformations produced in the glass bulb.

The available types of pyrometer, excluding the mercury thermometer, are three in number, namely, the thermo-electric couple, the electrical resistance pyrometer, and the radiation pyrometer. Of these, the first is by far the most important, from the great range of temperature over which it may be used, and the sensitiveness which may be imparted to it by a suitable disposition of the electrical parts. It depends on the measurement of the thermo-electric difference of potential produced when a junction of two dissimilar metal wires is heated or cooled, the other junctions being maintained at some constant temperature. In practice, the two wires forming the couple are welded together to form the hot junction, the cold junctions being the points at which the ends of the couple wires are joined to the galvanometer leads.

¹ F. Mylius and O. Fromm, *Ber.*, 1894, 27, 630; L. Kahlenberg, *Electro-chem. Ind.*, 1903, 1, 201; S. Field, *Trans. Faraday Soc.*, 1909, 5, 172.

² W. Kerp, *Zeitsch. anorg. Chem.*, 1898, 17, 284.

The metals used for thermo-couples are principally those of the platinum group. Other couples, such as those of iron and constantan or copper and constantan, develop a higher thermo-electromotive force, but their use is restricted to low temperatures. For measurements at high temperatures, it is necessary that the metals forming the couple should be highly infusible, and should also be unaffected by hot air. In both the couples in general use, one wire is of pure platinum, the other being an alloy of 90 per cent. platinum and 10 per cent. rhodium, or of 90 per cent. platinum and 10 per cent. iridium. The former is the more often used. The Pt-PtIr couple has the higher E.M.F. at a given temperature, but its use is restricted to temperatures below 1400° , in spite of its infusibility, as iridium is volatile, and the vapours cause contamination of the second wire. When it is desired to measure temperatures above the melting-point of platinum, the only couple available is one composed of wires of iridium and an alloy of iridium and ruthenium respectively, which has the disadvantage of being very brittle. For such extreme temperatures, optical methods are generally to be preferred. Whichever couple is used, the wires should be thoroughly annealed before any measurements are taken, and re-annealing at a high temperature is also desirable when a couple has been long in use, as the pure platinum wire readily absorbs gases.

The E.M.F. of a thermo-couple is not proportional to the temperature. Accurate comparisons of couples with the gas thermometer have been made,¹ and it has been found that the relation is most conveniently given in the form

$$E = a + b\theta + c\theta^2$$

in which E is the E.M.F. in microvolts, θ is the temperature, and a , b , and c are constants. A logarithmic formula, of the form

$$\log E = a \log \theta + b$$

is applicable over a somewhat wider range.

¹ L. Holborn and A. L. Day, *Amer. J. Sci.*, 1899, [iv.] 8, 165; J. A. Harker, *Phil. Trans.*, 1904, 203A, 343.

In practice, however, the temperature is best found from the E.M.F. by a graphical construction. If the couple is provided with a certificate, a table of the observed E.M.F.'s at a number of different temperatures is there given, and it is also desirable to make some determinations of the freezing-points of pure metals. The fixed datum-marks thus obtained are used for the construction of a curve, from which the temperature corresponding with a given reading is obtained with ease. It must be remembered that extrapolation beyond the highest point actually determined is attended with great uncertainty, and the equations expressing the relation between E and θ become less and less trustworthy as the temperature increases.

The above formulæ are based on the assumption that the cold junctions, that is, the points at which the wires of the couple make contact with the leads, are at 0° . This condition is not always convenient in practice, and for ordinary purposes it is better to use a water-bath at a constant temperature in the neighbourhood of 15° . The arrangement shown in Fig. 47 is suitable for this purpose, the junctions being enclosed in glass tubes closed with paraffined corks, immersed in a water-bath provided with a thermometer. A correction has to be made for the temperature of the cold junctions. Supposing this to be 15° , it is necessary to add a correction, amounting to 13.3° when the hot junction is at 100° , 11.4° at 200° , 8.8° at 400° , diminishing to 7.5° at 900° . Intermediate values may be found by interpolation.

When accurate measurements are being made, the necessity of applying a correction is avoided by filling the outer vessel in Fig. 47 with broken ice, so that the cold junctions are kept constantly at 0° . Some observers prefer to maintain this junction at 100° , by enclosing it in an apparatus in which water is boiling, a condenser being attached.

The wires constituting the couple should be 0.6 mm. thick and 60–100 cm. long, in order that the cold junctions may be at a safe distance from the furnace. To insulate one wire from the other, it is enclosed in a capillary tube, which may be of quartz or of porcelain, or, for very high temperatures, of magnesia, whilst the whole is enclosed in an outer protecting tube,

as described above. Outside the furnace, the wires are separated by being threaded through doubly bored fireclay rods about 6 cm. in length, which

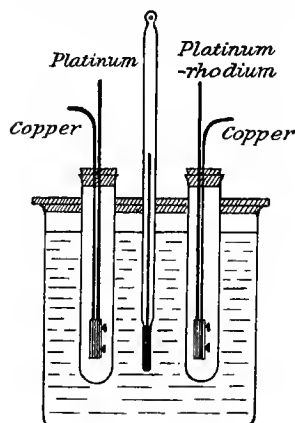

FIG. 47.—Cold junction.

may be obtained from the dealers who supply the thermo-couples. The attachment to the galvanometer leads is made by means of small double binding screws. The leads themselves are of insulated copper wire.

In the simplest method of measuring the thermo-electromotive force developed by the couple, the leads are connected directly with a galvanometer, such as a Siemens and Halske millivoltmeter, on the scale of which $1^{\circ} \text{C.} = 0.0001 \text{ volt}$, at 1000° , a platinum platinum-rhodium couple being used.

Such instruments are often provided with a scale graduated directly in temperatures, but the readings should be carefully calibrated from time to time by determining the freezing-points of pure metals. The following freezing-points are in common use for calibration:—¹

Metal.	Atmosphere.	Freezing-point.	Metal.	Atmosphere.	Freezing-point.
Tin . .	Air	232°	Cobalt .	Hydrogen	$1489.8 \pm 2.0^{\circ}$
Cadmium	„	$320^{\circ} \pm 0.3^{\circ}$	Palladium	Air	$1549.2 \pm 2.0^{\circ}$
Lead . .	„	327.4°	Platinum.	„	$1752 \pm 5^{\circ}$
Zinc . .	„	$418.2 \pm 0.3^{\circ}$	„	(optical)	$1755 \pm 5^{\circ}$
Antimony	Carbon monoxide	$629.2 \pm 0.5^{\circ}$			
Aluminium	„	$658.0 \pm 0.6^{\circ}$	Mineral.	—	Melting-point.
Silver . .	„	$960.0 \pm 0.7^{\circ}$			
Gold . .	„	$1062.4 \pm 0.8^{\circ}$			
Copper . .	„	$1082.6 \pm 0.8^{\circ}$	Li_2SiO_3 .	—	$1201 \pm 1^{\circ}$
Nickel . .	Hydrogen	$1452.3 \pm 2.0^{\circ}$	Anorthite	—	$1549.5 \pm 2.0^{\circ}$

¹ The figures are mostly taken from A. L. Day and R. B. Sosman, *Carnegie Inst. Publ.*, 1911, No. 157.

together with the boiling-points of water (100°) and sulphur (444.7°). The freezing-points of silver and copper are much lower in presence of air.

The accuracy of the millivoltmeter type of instrument is not very high. It is suitable for measuring annealing temperatures or for determining freezing-points when very high accuracy is not required, but it is not satisfactory as a means of investigating a series of alloys. The accuracy may be largely increased by the use of a suspended coil instrument with mirror, the readings of the spot of light reflected on a scale being taken. It is not worth while, however, to increase the sensitiveness of the galvanometer very greatly, as the direct method of measurement is subject to certain errors, depending on the change of resistance of the couple itself with temperature, which limit its accuracy.

The thermo-couple may be made self-recording, either by causing the spot of light to fall on a sheet of sensitized paper wound on a drum rotated by clockwork, as in the well-known recording instrument of Roberts-Austen,¹ or by means of a mechanism depressing an inked thread against paper at regular intervals.²

For greater accuracy, the E.M.F. should not be read directly, but should be balanced against that of a standard cell, a potentiometer being used to effect the balance. A special construction of the potentiometer is required, the E.M.F. to be measured being very small, whilst it is essential that readings should be taken in rapid succession. A null method does not provide the required rapidity of manipulation, and the device, due to Stansfield,³ of compensating the greater

¹ Fifth Rep. Alloys Research Committee, 1899.

² It is difficult to ensure a perfectly steady motion of the photographic or other paper, hence it has also been proposed to use a stationary photographic plate, the image being displaced by a mirror moved at a uniform rate (S. Wologdine, *Rev. de Métallurgie*, 1907, 4, 552).

³ A. Stansfield, *Phil. Mag.*, 1898, [v.] 46, 59. Another form of this installation, arranged for photographic recording, has been extensively used for metallographic purposes by the Russian investigators. See N. S. Kurnakoff, *Zeitsch. anorg. Chem.*, 1904, 42, 184. See also W. P. White, *Phys. Rev.*, 1907, 25, 334.

part of the E.M.F., leaving a small outstanding part to be read on a scale in the usual manner, is generally adopted. A large standard cell or a small secondary battery is used to produce the balancing E.M.F., and a sensitive Desprez-D'Arsonval galvanometer is used for reading. The sensitiveness may be so chosen that the whole range of the scale, some 60 cm. long, represents only 10° or 15° . When the spot of light has reached the end of the scale, the resistance of the potentiometer is altered, so reducing the balancing E.M.F. and bringing the spot back to the beginning of the scale. This plan is only suitable for slow cooling, as otherwise the time required for the oscillations of the galvanometer to die down may cause the loss of a reading. It is also affected by zero-creep, to which all suspended-coil galvanometers are liable, but with suitable precautions very accurate results may be obtained by its means.

In the various difference methods,¹ the difference of temperature between the specimen under examination and the furnace is measured at frequent intervals or continuously. Since the temperature of the furnace is not so readily or so accurately determined as that of a body enclosed in it, Roberts-Austen proposed the device of placing a neutral body, such as a mass of platinum, near to the body under examination and under the same conditions of temperature as it.² The neutral body is one which gives a perfectly regular cooling curve; it must not, therefore, present any discontinuity of thermal properties within the range to be observed. Platinum is obviously the most suitable substance for the purpose, although nickel may be used successfully for ranges of temperature which do not include its transformation point. The neutral body should be as nearly as possible of the same shape and size as the body investigated, in order that they may cool with

¹ Commonly called *differential* methods. Since, however, true differential methods of plotting, involving the differential coefficient of a function, are now frequently adopted, it is better to use the term *difference* method for one in which differences of temperature are measured.

² Fifth Report, Alloys Research Committee, 1899.

equal rapidity. The difference in specific heat of the two metals causes a departure from uniformity in cooling; but this error may be to some extent eliminated in plotting the curves, as described below.

In Roberts-Austen's method of working, the two thermocouples, placed in holes drilled in the specimen and the neutral body respectively, are connected so that the E.M.F.'s produced tend to neutralize each other, that is, the platinum wires of the

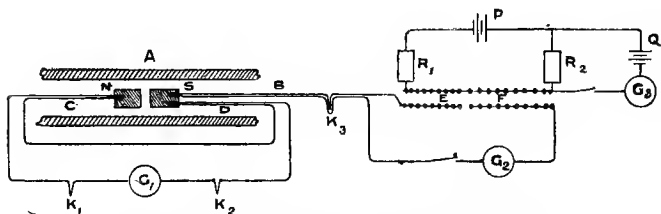

FIG. 48.—Potentiometer and difference method.

two couples are connected together, the other wires being connected with the galvanometer. So long as the bodies are cooling at the same rate, the galvanometer does not indicate the passage of any current; but any development of heat, caused by a polymorphic change in the specimen, gives rise to a difference of temperature $(\theta - \theta_1)$ between the two bodies, so that the galvanometer coil is deflected. The temperature θ of the specimen is observed at the same time, either by a separate thermo-couple, or by the shunting of one couple through a second galvanometer. The former arrangement is more suitable for accurate work, and is illustrated diagrammatically in Fig. 48.¹

The specimen S and the neutral body N are contained in the cylindrical electric resistance furnace A. The thermo-couple B is connected directly with the potentiometer, whilst the two couples C and D are so connected that their platinum-

¹ H. C. H. Carpenter and B. F. E. Keeling, *J. Iron Steel Inst.*, 1904, i. 224.

rhodium wires are joined, and their platinum wires lead to the galvanometer G_1 , the deflections of which measure $\theta - \theta_1$. K_1 , K_2 and K_3 are cold junctions, maintained at 0° . The balancing E.M.F. is furnished by the accumulator P , and is checked from time to time by means of the standard cells Q , of 1.019 volts each. R_1 and R_2 are resistance boxes, of which R_1 can be used for balancing Q against P until the deflection of the galvanometer G_3 becomes zero, R_2 having the resistance 1019 ohms. The potentiometer consists of four sets of nine coils each, arranged in two rows, and connection may be made

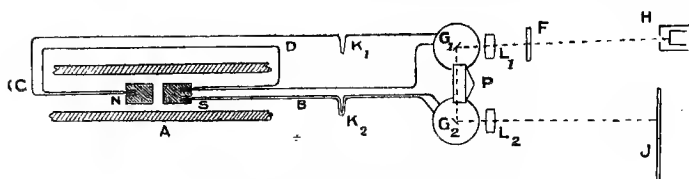

FIG. 49.—Saladin's difference method.

between them at any two points by the plugs E and F . The coils in the left-hand half are of 2 ohms each, and those in the right-hand half of the potentiometer 0.2 ohm each. Each 0.2 ohm between E and F then corresponds with about 400 microvolts. The thermo-couple being connected by the key, balance is found to the nearest 400 microvolts, and the outstanding E.M.F. is read off by means of the galvanometer G_2 , which is a sensitive suspended coil instrument, with mirror, giving a deflection on the scale of 8 mm. for 1° , so that very small changes in $\theta - \theta_1$ may be read off.

The reading of the time is eliminated altogether in the ingenious recording method of Saladin,¹ by which $\theta - \theta_1$ is plotted directly against θ . The photographic plate on which the record is made is stationary, and the beam of light is reflected by the mirrors of both galvanometers. The arrangement is shown in its most useful form in Fig. 49. The

¹ *Assoc. intern. Methodes d'Essais*, February, 1903, described by H. Le Chatelier, *Rev. de Metallurgie*, 1904, 1, 134.

specimen, neutral body and thermo-couples are arranged as before, and their lettering corresponds with that of Fig. 48. The two galvanometers, G_1 and G_2 , are placed side by side on a common base, rendered as free from vibration as possible by layers of lead and felt. A beam of light from the Nernst lamp H, issuing through a narrow slit, passes through the colour-filter F, and is rendered parallel by the lens L_1 before falling on to the mirror of the sensitive galvanometer G_1 , the deflections of which are proportional to $\theta - \theta_1$. These deflections are naturally in a horizontal plane. The reflected beam now enters a totally-reflecting prism P, inclined at an angle of 45° . The horizontal displacements of the ray are in this way converted into vertical displacements before reaching the second galvanometer, G_2 , which measures the temperature, θ . The mirror of G_2 must be of sufficient height to receive the reflected ray from G_1 at its maximum displacement. The beam of light leaving G_2 has now a double motion impressed on it, a vertical one due to G_1 and a horizontal one due to G_2 . It is focussed by the lens L_2 on to the plate J, where it records itself as a fine curve, the ordinates of which are the values of $\theta - \theta_1$ and the abscissæ those of θ . If a record of the time is also required, this may be effected, as proposed by Le Chatelier, by interposing a toothed wheel (a disc of cardboard into the edge of which pins are fastened at regular intervals) in the path of the ray between H and L_1 . This wheel is rotated by the mechanism of a small clock, and produces short interruptions in the curve at definite intervals of time.

It is necessary that G_2 should be free from zero-creep, which gives rise to errors in the temperature at which the development of heat occurs. The same apparatus has been used for recording temperature-time curves with a single thermo-couple.¹ This is connected with G_2 , whilst the deflections of G_1 are made proportional to the time, a cell being connected with the galvanometer through a very high resistance (10,000 ohms). This circuit is divided, one branch including the galvanometer, whilst the other includes a fine platinum wire dipping into mercury. By means of a regulating

¹ H. Harkort, *Metallurgie*, 1907, 4, 639.

water-flow, the level of the mercury can be progressively altered, thus varying the resistance of the circuit, and causing a continuous displacement of the galvanometer mirror.

In the electrical resistance pyrometer, advantage is taken of the change of resistance of a platinum wire with temperature.¹ This method of pyrometry is admirably adapted to work of great precision, since very minute differences of temperature may be determined by its means. It is, however, less suited to the work of thermal analysis than the thermo-couple, on account of the greater difficulty of reading, and also of the comparatively large mass of the thermometer portion of the instrument, which renders it difficult to follow rapid fluctuations of temperatures. The method is interesting as having been employed by Heycock and Neville in their investigations of the freezing-points of metals and alloys, undoubtedly the most accurate series of measurements of this kind ever made.² The end portions of the freezing-point curves, which are of great importance as giving information as to the molecular condition of alloyed metals, were, in particular, determined by these investigators with great precision.

In the original form of instrument the platinum wire is wound on a mica frame enclosed in a porcelain tube. In a later form the wire is wound on a quartz rod, which is then slipped into a thin quartz tube, the latter being finally fused on to the rod, so embedding the wire in quartz. This gives a very narrow bulb, occupying little more space than a thermo-couple. The resistance is measured by a Wheatstone bridge arrangement, which may be made self-registering.

Several forms of optical and radiation pyrometers have been employed for work at very high temperatures. None of these are suitable for the determination of cooling curves, but they find application in metallography in the measurement of melting-points of substances fusible with difficulty, and in the determination of furnace temperatures in quenching experiments, etc. The optical pyrometer depends on the comparison

¹ H. L. Callendar, *Phil. Trans.*, 1887, 178A, 161; H. L. Callendar and E. H. Griffiths, *ibid.*, 1891, 182A, 119.

² C. T. Heycock and F. H. Neville, *Trans. Chem. Soc.*, 1895, 67, 160.

of the light emitted by the specimen with that from a standard source, only rays of a particular wave-length being selected for comparison. In the Holborn-Kurlbaum instrument¹ an electric glow-lamp is used as the standard source, the current passing through it being adjusted until the image of the filament just disappears on the field illuminated by the radiating body, a red glass being interposed to select a certain group of radiations. With the cuprous oxide glass used by Holborn, the radiations transmitted have their centre at $\lambda = 0.643\mu$. The relation between the current passing through the filament and the temperature, assuming the emitting object to have the properties of a black body, is given by a parabolic formula. The intensity I of the monochromatic radiation varies with the temperature, according to Wien's law—

$$I = C\lambda^{-5}e^{-\frac{c}{\lambda T}}$$

where T is the absolute temperature, and C and c are constants. Very high temperatures may be measured by using a tungsten or other metallic filament as the standard source. The instrument is readily calibrated by observing a series of melting-points of pure metals.

In the Wanner pyrometer, which is extensively used in metallurgical laboratories, coloured glasses are avoided, and the lamp is run on a constant current. The beams of light from the object and the standard lamp are decomposed by a direct vision prism, and brought together in a photometer. One or the other is weakened by turning a pair of polarizing prisms until the intensities are equal.

The Holborn-Kurlbaum pyrometer has been utilized for the determination of melting-points of metals belonging to the iron group.² A blackened brass cylinder was used, enclosing an electrically heated strip of thin platinum, on which the fragments of metal could be placed. The vessel was filled with hydrogen to prevent oxidation. The pyrometer was directed on to the platinum, and the temperature read at

¹ L. Holborn and F. Kurlbaum, *Ann. Physik.*, 1903, [iv.] 10, 225; L. Holborn and S. Valentiner, *ibid.*, 1907, [iv.] 22, 1.

² G. K. Burgess, *Bull. Bureau Standards*, Washington, 1907, 3, 345.

the moment of fusion. Two corrections were necessary, one depending on the selective emission of the platinum for the ray selected, $\lambda = 0.66\mu$, and the other on the loss of light by reflection and absorption in passing through the mica window provided for observation.

The melting-points found by this method—namely, iron, 1505° ; chromium, 1489° ; cobalt, 1464° ; nickel, 1435° ; manganese, 1207° —are in good agreement with the freezing-points found by other observers.

The Féry radiation pyrometer measures the heat radiation, which is related to the temperature by the Stefan-Boltzmann law, according to which

$$E = k(T^4 - T_0^4)$$

E being the energy radiated, T the absolute temperature of the body, T_0 that of the surroundings, and k a constant.

The instrument is set up like a telescope at some distance from the heated object. The tube contains a concave mirror, by means of which the radiations are focussed on to a small thermo-couple, the E.M.F. of which is read by a galvanometer in the usual way. The temperature readings obtained are, within certain limits, independent of the distance of the pyrometer from the object. It is only necessary that the object should be near enough for its image to overlap the small thermo-couple. If this condition is fulfilled, moving the pyrometer towards the object enlarges the image, but the part of it that falls on the couple is of the same size as before.

Radiation pyrometers only give the correct temperature if the emissive power of the object is that of a black body. This is not often the case, but "effectively black" radiations are emitted by surfaces in the interior of a uniformly heated space, so that the inner wall of a muffle, etc., may be considered as having the emissive power of a black body. When taking the temperature of a furnace, it is advisable to insert a fireclay tube, closed at one end, in the furnace, the opening facing towards the pyrometer, which is arranged to form an image of the closed end of the tube. This gives very closely the true temperature of the furnace.

The radiation pyrometer is useless for measuring temperatures if flames or heated vapours having high absorptive power intervene between it and the object, and the same objection applies, although not quite in the same degree, to the various forms of optical pyrometer. The advantage of these pyrometers in dealing with very high temperatures is that the radiation increases very rapidly with the temperature, namely, in proportion to the fourth power of the latter, and very small differences of temperature are therefore measurable. Further, the radiation equations used in their calibration are in close agreement with the gas scale throughout the whole observed range, and extrapolation may therefore be resorted to with confidence.¹

THE COOLING CURVE

The simplest form of cooling curve is that illustrated in Chapters II. and III., in which the temperature of the mass is directly plotted against the time.² In its construction, the readings of the galvanometer are taken every 10 or 15 secs., and utilized directly for the construction of the curve. This method is adapted to the measurement of freezing-points, but not to that of changes taking place in the solidified mass, on account of its comparative insensitiveness. Curves of this type are referred to as "direct" cooling curves. Whilst they indicate, with an accuracy dependent on that of the galvanometer, the temperature at which each change of state takes place, and the range over which each development of heat continues, they only give a rough idea of the magnitude of the development, and a quantitative interpretation of the curve is impossible. This is due to the fact that the rate of cooling is not uniform, being different at the beginning and at the end of the change of state. Direct cooling curves may, however, be so modified as to yield quantitative information, by the

¹ On optical and radiation pyrometry, see L. Holborn, *Brit. Assoc. Rep.*, 1907, Leicester, 440; C. Féry, *ibid.*, 442; C. W. Waidner and G. K. Burgess, *Bull. Bureau Standards*, 1904, 1, 189.

² Frankenheim, *Ann. Physik.*, 1836, [ii.] 39, 376; F. S. Schaffgotsch, *ibid.*, 1857, 102, 293.

employment of an electric furnace, the temperature of which is diminished at a uniform rate by the gradual increase of resistance in the external circuit. The means of effecting this have been described on p. 102, and the nature of the curves obtained may now be discussed.

A perfectly inert body cooled in this way at a sufficiently slow rate, will at each moment have the same temperature as the furnace, and the readings of a thermo-couple in contact with it, plotted as a temperature-time diagram, will give a straight line (*af* in Fig. 50). If a molten metal is cooling at a sufficiently slow rate, the difference in the specific heats of the liquid and solid will be without influence on the form of the cooling curve, as the temperature of the metal will in both cases be that of the furnace, *ab* and *ef* will therefore remain in the same straight line. If freezing begins at *b*, the heat liberated during crystallization causes the cooling curve of the metal to assume the form *bcde*. The portion of the curve *bc* is not quite horizontal, but falls somewhat, the deviation being greatest with substances of low thermal conductivity. The portion *de* is also rounded off slightly. The area included between *bcde* and the straight line *bc* is proportional to the heat liberated during freezing.¹ This area may be measured, either by cutting out in paper and weighing, comparing the weight with that of a measured rectangle, as recommended by Plato, or more conveniently and accurately by means of the planimeter.

The measurement of this area provides a means of determining the latent heat of fusion, a quantity which is required to be known when discussing the interpretation of the freezing-point curve. It is necessary to know the latent heat of one substance, and a comparison of the cooling curves of this substance and of the one under investigation, other conditions being the same, enables the latent heat of the latter to be calculated. For the method of calculation, reference must be made to the original papers. The method has only been applied hitherto to salts, and the latent heats of fusion determined by its means are in good agreement with those measured

¹ W. Plato, *Zeitsch. physikal. Chem.*, 1906, 55, 721; 1907, 58, 350; 1908, 63, 447.

calorimetrically; it is therefore to be expected that it will prove of considerable value in the study of metallic alloys. In Fig. 51, the types of curves obtained in Plato's furnace from a mixture depositing crystals of a solid solution (*a*), and of an alloy depositing crystals of a pure component, followed by solidification of the eutectic (*b*), are shown. The exact form of the arrests is clearly more easily distinguished than in curves obtained in a furnace which is cooling freely by radiation.

When the change under observation is not the freezing of a liquid, but the transformation of one solid phase into another,

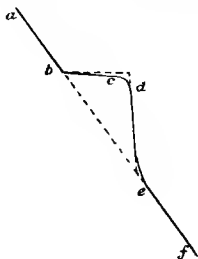

FIG. 50.—Cooling curve.

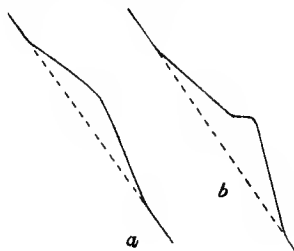

FIG. 51.

the liberation of heat is generally neither so great nor so instantaneous, and the indications on the time-temperature curve become uncertain and difficult to interpret. They are brought out more clearly by the device of plotting "inverse-rate" curves, in which the temperatures are taken as ordinates, and the inverse rates of cooling (times taken for the temperature to fall through a definite small amount) as abscissæ. Denoting temperature by θ and time by t , the "direct-rate" curves have as co-ordinates θ and t , whilst the "inverse-rate" curves have as co-ordinates θ and $dt/d\theta$.¹ A development of heat appears on such a curve as a "peak," the position of which can be located without difficulty, but on account of the uncertainty as

¹ The different types of cooling curves are discussed and compared by G. K. Burgess, *Bull. Bureau Standards*, 1908, 5, 199; and W. Rosenhain, *Proc. Phys. Soc.*, 1908, 21, 180.

to the points at which the curve leaves the neutral line and returns to it, a quantitative interpretation is not feasible. The "inverse-rate" method is of interest as having been employed by Osmond in his original work on the allotropy of iron and its alloys with carbon.¹ For accurate work, a chronograph is required to mark seconds on a tape, a key being depressed each time that the E.M.F. increases by a fixed amount. In this way, the time taken by the specimen to cool through 1° or a smaller interval is recorded.²

The rate of cooling, $d\theta/dt$, may also be plotted against the temperature, instead of $dt/d\theta$. An apparatus, involving the use of two thermo-couples, has been devised for this purpose.³

In accurate work on the transformations of solids, however, one or other of the difference methods is most often adopted, the temperature of the body under investigation being compared with that of a body cooling without undergoing polymorphic change of any kind. The curve representing the development of heat in the transformation of a cooling metal or alloy has then a very clearly marked character.

The irregularities occurring in difference curves, due to differences between the specific heats and radiating powers of the specimen and the neutral body, are largely eliminated in the method of graphical representation due to Rosenhain (*loc. cit.*), in which the co-ordinates are θ and $d(\theta - \theta_1)/d\theta$, that is, the slope of the difference curve is taken, and is plotted against the temperature. Such a curve is called a "derived differential" curve, since the quantity plotted against the temperature is the differential coefficient of $\theta - \theta_1$ with respect to temperature, that is, it is the slope of the ordinary difference curve.

The effect of the several methods of plotting is compared in Fig. 52. A method of observation similar to that represented in Fig. 48 being used, the following readings of time,

¹ F. Osmond, *Mém. Artill. Marine*, 1887, 15, 573; *J. Iron Steel Inst.*, 1890, i, 38; *Compt. rend.*, 1890, 110, 242, 346. The chronographic method of obtaining inverse-rate curves is preferred to the difference method by J. O. Arnold, *Internat. Zeitsch. Metallographie*, 1911, 1, 192.

² F. Wüist, *Metallurgie*, 1906, 3, 1.

³ P. Dejean, *Rev. de Métallurgie*, 1905, 2, 701; 1906, 3, 149.

temperature, and difference of temperature between the two bodies are obtained; each unit in t signifying 15 seconds.

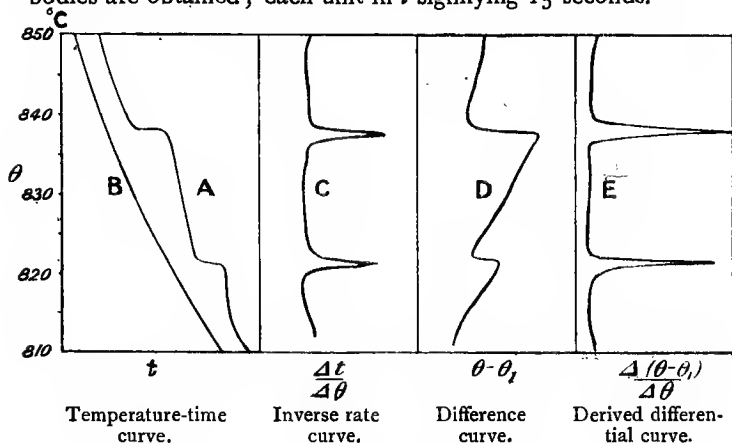

FIG. 52.

t	θ	$\theta - \theta_1$	t	θ	$\theta - \theta_1$
5	850.0°	8.5°	18	829.0°	11.0°
6	848.0	8.5	19	825.0	8.2
7	844.7	7.5	19.5	823.3	7.3
8	842.0	7.0	20	822.2	6.7
9	839.5	6.3	21	821.7	7.7
10	838.5	7.0	22	821.5	8.5
11	838.2	8.8	23	821.3	9.8
12	838.1	10.2	24	821.1	10.1
13	838.0	12.0	24.5	819.0	9.5
14	837.9	13.6	25	815.0	6.0
15	837.5	15.5	26	813.0	5.0
16	836.0	14.6	27	811.6	4.7
17	833.0	13.0			

In curve A (Fig. 52), the values of θ are plotted directly against those of t , giving an ordinary cooling curve. Two developments of heat are indicated, the second one beginning immediately at the close of the first. The curve B is the cooling curve of a neutral body added for comparison. By reading off from the curve A the values of t at each successive 1° C., and tabulating the differences, we obtain a further series of

numbers, and the differences between successive values then represent the time taken to cool through 1° , which may be represented by $\frac{\Delta t}{\Delta \theta}$. These values may be obtained directly if a chronograph is used. Plotting these differences against θ , we obtain the curve C. The difference curve D, constructed by plotting the values of $(\theta - \theta_1)$ in the table against θ , shows the developments of heat with great clearness, indicating both the commencement and the termination. Lastly, the curve E is obtained by measuring the change of $(\theta - \theta)$ for each 1° change of θ , or, more strictly, the slope of D at each point, and plotting these values against θ .

The close resemblance between the curves C and E will be noticed. In both cases the area of a "peak" is proportional to the development of heat due to the change in question, but this fact loses much of its value since the area is very difficult to determine. It will be seen that, whilst the commencement of the change is indicated with great sharpness by both of these curves, the end of the change is hardly to be detected, and the measurement of the area is consequently difficult to perform.

A method of plotting, giving very well-marked arrests, suitable for the measurement of arrest times, has been employed in the study of the ternary alloys of mercury.¹ Pure mercury, which remains liquid within the range covered by the experiment, is cooled under the same conditions as the alloy under investigation. Readings are taken of the time at which the mercury and the alloy respectively reach certain temperatures, that is, time readings are taken every 5° or 2° . This necessitates a very slow rate of cooling, and the co-operation of two observers. The two sets of readings, plotted separately, give two curves, of which the mercury curve is smooth, whilst the alloy curve presents the aspect of an ordinary temperature-time curve with an arrest. The time readings of the mercury curve are now subtracted from those of the alloy curve at the same temperatures, and the differences are plotted against temperature. In this derived curve, the ordinates are θ , and the abscissæ $(t - t_0)/\Delta \theta$. Examples of the ordinary curve,

¹ E. Jänecke, *Zeitsch. physikal. Chem.*, 1906, 57, 507; 1907, 60, 399.

and of the derived curve corresponding with it, are shown in Fig. 53. The arrest-time is very easily measured on the latter. The dip in the curves at the commencement of freezing is due to undercooling, as will be explained in Chapter X.

In concluding this chapter, it may be well to add a few general remarks on the preparation of alloys for thermal examination. In the first place, it is of the highest importance that the metals selected as the ingredients of the alloys should be of the greatest attainable purity. Whilst one or two per cent. of a foreign metal may be without marked effect on the

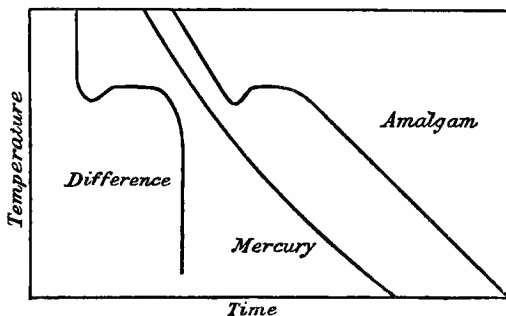

FIG. 53.—Jänecke's method of plotting cooling curves.

general form of the freezing-point curve, if duly allowed for in plotting the results, this does not justify the use of material containing such a proportion of impurity, since an element of uncertainty is thereby introduced, and the effect on other properties of the alloys may be much more considerable. Polymorphic changes are sometimes affected to a marked extent by the presence of small quantities of another element, especially of a non-metal. Moreover, the determinations of any physical properties of the alloys are rendered valueless by such a procedure. Chemical and metallurgical literature is already unfortunately overburdened with data respecting physical properties of alloys, the material for which was in too many cases taken from a laboratory stock without any previous chemical investigation. In the writer's experience, elaborate physical researches, involving prolonged and laborious

determinations of a high degree of accuracy, have been conducted with material described as "copper wire," "zinc in sticks," etc., which a chemical analysis would have shown to be worthless for the purpose.

It is not difficult to procure metals of the requisite degree of purity, except in a limited and diminishing number of cases. Putting aside fine gold and silver, the high purity of which is well known, the demands of the electrician and the engineer have led to the production on the large scale of copper which approaches the best scientific preparations in its freedom from all but the minutest traces of impurity. The best qualities of zinc, tin, antimony, lead, and aluminium are also of a very satisfactory degree of purity. Iron, either in the form of the best Swedish wrought iron or of the practically carbonless steel used for transformer cores, is readily obtainable, and is more satisfactory than electrolytic iron prepared in the laboratory, which is liable to contain impurities derived from the electrolyte. In fact, it may be said that laboratory preparations of metals, unless means of working on a fairly large scale are available, are generally much less satisfactory than the best commercial products. The less common metals may often be obtained in a pure form from Kahlbaum. It is desirable that all raw materials should be analysed before use.

It is a common practice to assume the composition of the alloy from the weights of the components taken in its preparation. Should one of these be volatile, as zinc or arsenic, or readily removed by oxidation during melting, as manganese or magnesium, an analysis is made of two or three of the alloys after melting, and the loss computed and applied to the correction of the other alloys of the series. This practice is to be condemned. Variations in the amount of volatilization or oxidation are very liable to occur, and it should be an invariable rule that all alloys should be analysed after their cooling curves have been taken. A complete analysis is not of course necessary in every case, as if one metal in a binary alloy be estimated accurately, the quantity of the other may commonly be determined by difference. A few alloys of each series should, however, be analysed completely, in order to

detect the absorption of impurities during melting. This is especially necessary when dealing with alloys of high melting-point, which are very liable to take up silicon, etc., from the crucibles in which they are contained or from the tubes used to protect the thermo-couples.

Before analysing an alloy which has been melted, the mass removed from the crucible should, if possible, be sawn through vertically. Any lack of uniformity in composition may generally be detected in this way. Should the alloy have separated into two liquid phases, these will be recognized as two layers in the solidified mixture, or if stirring has been so vigorous that separation has not taken place so completely, the one constituent may be seen distributed in the form of globules through the mass, as in rapidly cooled alloys of copper and lead. When the crystals which separate at the initial freezing-point are of lower specific gravity than the mass of the alloy, they float up to the surface, and cause a corresponding concentration of that constituent in the upper part of the ingot. Thus, in ternary alloys of lead, tin, and antimony, the cubical crystals approximating to the composition SbSn float to the surface, and are seen on sawing through the ingot and filing to a flat surface, without the necessity of polishing or examining under the microscope. Should such a lack of homogeneity be recognized, it is advisable to re-melt the alloy, and to cool rapidly with constant stirring. It is better not to trust to making analysis of the upper and lower portions of the ingot separately and averaging the results.

The presence of non-metals as well as metals should be looked for in the analysis if opportunity for their access to the alloy has occurred. It seems probable that abnormal results obtained by some investigators with alloys of manganese are due to the presence of carbon (see p. 52, *footnote*), whilst the same element is no doubt responsible for the fact that whilst copper and iron are now known to alloy with one another in all proportions,¹ they have been described as being immiscible

¹ J. E. Stead, *J. Iron Steel Inst.*, 1901, ii. 104; H. Wedding and W. Müller, *Stahl u. Eisen*, 1906, 26, 1444; R. Sahmen, *Zeitsch. anorg. Chem.*, 1908, 57, 1.

in the liquid state.¹ It has in fact been shown by Stead that iron containing carbon is not miscible with copper.

Lastly, reference should be made to the quantity of alloy necessary for a satisfactory pyrometric investigation. Most observers have employed very small quantities, of from 10 to 20 grams, but there are serious objections to such a procedure. Not only is it difficult to attain a sufficiently slow rate of cooling, on account of the large surface presented by the alloy in proportion to its weight, but the mass of the thermo-couple and its protecting tubes bears too large a proportion to that of the alloy, and small changes in the direction of the cooling curve may be entirely overlooked. The National Physical Laboratory, which has set a good example of careful work in its published investigations, recommends from 120 to 300 grams as a suitable quantity of alloy for determination of freezing-points. Similarly, Day and Sosman (*loc. cit.*) recommend the use of a mass of metal measuring about 25 mm. in diameter, and 45 mm. deep. There are, of course, several difficulties, apart from that of cost of material, involved in work on so large a scale, which may deter the investigator who has not the resources of a large laboratory at his disposal. The large crucibles required are both more costly and more fragile than those which suffice in dealing with smaller quantities, and care is required in the selection of fire-resistant materials for their construction if high temperatures are to be employed. Larger furnaces are also necessary for heating the alloys. The initial cost of the metals may be minimized by using the same material for several alloys, removing portions of the ingot after cooling for analysis and microscopical examination and re-melting the remainder with a further quantity of one of the components. Should the alloy be one which acts chemically on the crucible, or absorbs gases from the atmosphere of the furnace, such repeated re-melting has the disadvantage of causing an accumulation of impurities, which must be looked for on analysis.

Such precautions may appear excessive, but it is important

¹ J. Riley, *J. Iron Steel Inst.*, 1890, i. 123; V. O. Pfeiffer, *Metallurgie*, 1906, 3, 281.

to insist on their necessity. Determinations of freezing-point curves, if undertaken at all, should be performed with the utmost available accuracy. The knowledge of alloys has now reached a point at which there is no need for more rough preliminary surveys, especially as the points which are of the greatest theoretical importance are precisely those which are most likely to be overlooked in an incomplete investigation. On the other hand, an extensive field for research is afforded by the transformations of solid alloys, which are best studied by the method of difference curves, and for these smaller quantities, from 20 grams upwards, suffice, owing to the superior sensitiveness of the method. Metallography, more than most branches of physical chemistry, has suffered in the past from the accumulation of inaccurate data, and it is well that the investigator should take every precaution to avoid adding to their number.

CHAPTER VII

THE PREPARATION OF MICRO-SECTIONS

THE preparation of thin, transparent sections, such as are employed in the study of rocks and minerals, is not possible in the case of metals and alloys, which remain opaque in the thinnest slices. It is therefore necessary to examine prepared surfaces by means of reflected light, only a single surface of each specimen being as a rule utilized. Whenever the metal is sufficiently soft to allow of it, the specimen is sawn to the required size with a hack-saw. With a little practice, it is not difficult to cut sections of regular form, with parallel faces, from a piece of metal held in a vice, by means of a hand-saw. Brasses, bronzes, etc., are more easily sawn than such tough metals as copper or aluminium, in cutting which some practice is required to overcome the drag on the teeth of the saw. Soap solution should be applied to lubricate the saw and to prevent heating, unless the alloy is of such a composition as to be affected chemically by water or alkali, in which case turpentine may be employed. Electrolytic calcium may be cut by moistening the saw with alcohol.

A convenient size for micro-sections is from 10 to 15 mm. square, and from 4 to 7 mm. in thickness. Larger specimens are not easy to polish uniformly, but it may of course be necessary sometimes to use larger sections when it is desired to include the whole of some structure or flaw. Specimens which are too thick are apt to rock slightly when held in the hand during grinding and polishing, so that the surfaces become rounded instead of flat. If too thin, the sections are liable to "buckle," so that the centre becomes hollowed, and

escapes polishing. When thin sheet metal is examined, it should be cemented to a piece of thicker metal to serve as a support. Cross-sections of wires may be examined either by drilling a hole in a small block of soft steel, into which the wire may be fitted tightly by tapping with a hammer, or they may be embedded in white metal, as described below (p. 145) for the edges of sections.

When a number of sections have to be cut, or when the ingots or bars to be sampled are of considerable size, a mechanical saw is of great assistance. A hack-saw moved horizontally in guides by means of a crank gives the best results, the metal to be cut being clamped in a vice, and a steady load, which may be varied according to the hardness of the metal, being applied by means of a sliding weight. Light saws of this kind, adapted to be driven by either hand or power, are to be found in most metallurgical laboratories. An automatic trip arrangement throws the saw out of gear when the specimen is cut through. Soap solution should be applied to the saw from time to time with a brush.

Care must be taken to ensure that the micro-section is representative of the metal under examination. When there is any doubt as to the homogeneity of the mass, sections should be cut from both the outer and inner portions. Much useful information is often obtained by cutting serial sections, representing the change of structure on proceeding from the surface to the centre of an ingot or of a forging. Ingots which have been cast in iron moulds have a chilled outer layer which may be quite different in structure and even in composition from the general mass. The outer skin should also be removed from small specimens which have been annealed or quenched in the laboratory, as surface changes are likely to occur during heating, even when care has been taken to avoid the access of air, copper-zinc alloys losing a portion of their zinc, steels becoming superficially decarburized, etc.

Many alloys are too hard to be cut with a saw, or so brittle as to crumble under the pressure. It is then necessary to break off a piece of the alloy with a hammer, and to grind a flat surface. Hard alloys which are not brittle, such as certain

steels, must be cut with a carborundum disc. For very hard alloys, such as white cast-iron, or the alloys of iron with chromium, tungsten, etc., an emery or carborundum wheel must be used for grinding, care being taken that the supply of water is sufficient to prevent heating. For alloys which are friable without being so hard as white cast-iron, a more satisfactory plan is to prepare a flat surface by grinding by hand on a carborundum block, moistened with water or turpentine. A torn or pitted surface is less likely to be produced in this way than when a mechanically driven wheel is used. The specimen should not in any case be allowed to heat up by friction. When a piece of metal is felt by the fingers to be distinctly hot, the surface which is being rubbed is at a considerably higher temperature, and in some cases, especially in that of steels hardened by quenching, important structural changes may be produced.

If the alloy is not too brittle, the sawn surface may now be made approximately flat by means of a file. For this purpose, a flat file is held in the left hand, with the end resting on the bench, and the specimen, held by the thumb and finger of the right hand, is drawn lightly up and down its surface. The proper pressure to be applied varies with the nature of the metal or alloy, and can only be determined by experience. It is to be remembered that the teeth of the file strain the metal, especially if soft, to some depth below the surface, and the lines of strain may reappear after polishing. It is often better to avoid the use of a file, and to prepare the surface of the specimen by rubbing with a circular motion on a piece of coarse emery cloth laid on the bench. All sharp edges and corners must be bevelled with the file before proceeding further, in order to prevent tearing of the cloth or paper used in the subsequent processes.

PREPARATION OF A SMOOTH SURFACE

In the majority of cases, the preparation of a surface suitable for polishing is effected by rubbing on emery paper. Fine carborundum hones, such as are used for sharpening

knives, are also used, but are expensive, and are also liable to become clogged when soft metals are being treated. French emery papers, prepared for jewellers' use, are generally employed, and can be obtained in four grades, 0, 00, 000, and 0000, the last being the finest.¹ The rubbing can now be performed by hand or mechanically. Although the hand method is naturally more tedious than the mechanical, it is to be recommended to the beginner, and is in certain cases indispensable. In order to carry it out, strips of the emery papers, conveniently about 20 cm. long and 6 cm. wide, are placed on a hard support, such as plate glass or hard wood. A convenient plan is to cement each strip to the surface of a small school slate with seccotine. Before using a new paper, the surface should be well rubbed with a piece of steel (an old micro-section) to remove any coarse particles. There is no advantage in preparing one's own emery papers.

The specimen, held between the fingers, is now rubbed backwards and forwards on the strip of paper 0 with a light pressure, care being taken to avoid tilting on reversing the direction, which would cause rounding of the edges. The rubbing is continued until, on examination with a hand lens, no scratches are seen except the parallel series due to the 0 paper. The process is now continued with the finer papers. On passing from one paper to another, the specimen is turned through a right angle, so that the new scratches cross the old at right angles. In this way it is easy to see when the coarser scratches have been effaced. On leaving the last emery paper, the surface should reflect the image of a lamp or window brilliantly, and should only show very fine parallel scratches under a lens.

Much time is saved when hard metals are being examined by employing a machine for polishing, by means of which the emery papers, attached to discs, are rotated rapidly while the specimen is moved slowly across them. A horizontal disc, mounted on a vertical spindle passing through a bearing and resting on a footstep bearing, may be used, the papers being

¹ A still finer quality, marked 05, is now supplied by Messrs. Dujardin & Co., Düsseldorf.

glued to detachable hard wood or brass discs. Wheels rotating in a vertical plane are used on the Continent and in America, but are less convenient. The most useful form of machine is that devised by Stead. In this form the

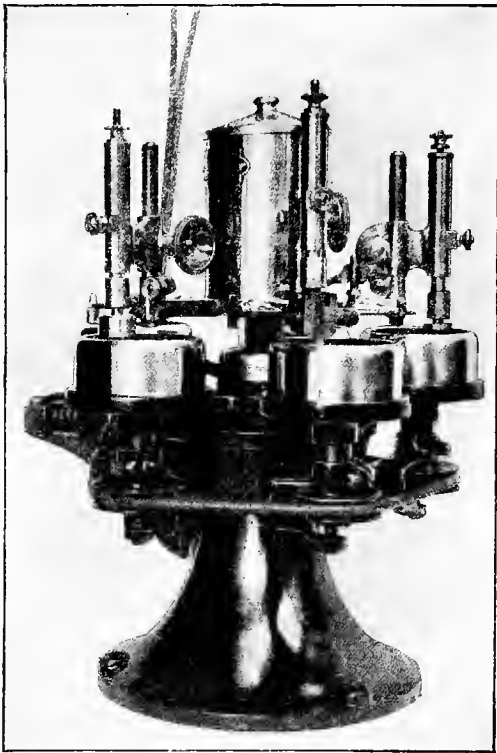

FIG. 54.--Polishing machine with five discs and automatic holders.

brass discs are attached to vertical spindles and driven from below. The machine illustrated (Fig. 54) has five such spindles, but smaller machines have only a single spindle. Conical mahogany blocks, 6 cm. in diameter, fit on to the brass discs and are held by friction, circular pieces of emery

paper being placed on these blocks and held in position by a brass ring slipped over them. The discs being run at a high speed (1200 revolutions a minute) by an electric motor, the specimen is held in the fingers and moved slowly in the opposite direction to that in which the emery paper is travelling. The scratches obtained in this way are very regular, and the preparation of a surface fit for polishing is complete with most metals in a few minutes. Hard steels, and other metals which require long rubbing to efface the scratches, are preferably held in a clamp. The machine shown is provided with three such clamps. The specimen, held in a small vice chuck or cemented to a flat chuck with plaster or glue, is pressed on to the block by the holder seen in the figure, the pressure being regulated by the spring and milled nut. This holder is given a slow to-and-fro motion by means of the arm shown, attached to an eccentric, so that the specimen is slowly moved about on the rotating disc. The water vessel shown is required for the subsequent stage of polishing. Machine grinding should, however, only be employed with hard metals or when a large number of moderately hard samples have to be examined. For all delicate work, hand grinding is greatly preferable, and is indispensable when soft alloys are under investigation. It is impossible to develop satisfactorily by mechanical grinding a eutectic containing lead.

POLISHING

The process of rubbing on emery paper is really one of cutting. Microscopical examination shows that the particles of emery cut grooves in the metal, the section of each groove being approximately parabolic. A certain amount of plastic deformation also occurs in the neighbourhood of the groove, this being the greater the coarser the scratch. Hence the final scratches should be very fine in order to avoid the presence of a deep surface layer of strained metal. The effect of the emery on brittle metals, however, is to break out small conchoidal chips, as in grinding glass, the chips being smaller the finer the emery. It was long supposed that the effect of

polishing with powders on cloth was merely to continue this process, the grooves or pits becoming so fine as not to be visible under the microscope. The recent researches of Lord Rayleigh,¹ Osmond and his collaborators,² and Beilby,³ have shown, however, that the process of polishing is essentially different from that of grinding. The full bearing of these investigations will be discussed in Chapter XVI., but here it will be sufficient to say that the production of a polished surface consists in the formation of a thin layer of "flowed" metal on the surface, the irregularities of the scratched surface being partly rubbed away and partly filled up. This plastic behaviour of the surface layer is readily observable even in such a brittle metal as antimony.

The powders employed in polishing are the oxides of aluminium, iron, magnesium, and chromium. French chalk and other substances which have been used give very inferior results. The most generally useful powder is alumina, prepared by igniting ammonium alum and levigating. Rouge (a fine form of ferric oxide) has been more used by metallographists than any other oxide, and it undoubtedly produces the most brilliant polish; but it has the disadvantage of causing an excessive flow of the surface layer, so that on developing the structure by etching, the outlines of the constituents are often found to be blurred and confused. It is useful in polishing hard steels, and, if very fine, in giving the finishing touches to metals of moderate hardness. It should not be used for very soft metals.

For most purposes it is not necessary to prepare the powder in the laboratory. The Swiss product sold for jewellers' use as "Diamantine No. 2" gives excellent results, except for the most delicate work with high powers, and does not drag the surface as does rouge. It is only when extremely fine detail is to be developed that a finer powder is required, and

¹ *Proc. Roy. Inst.*, 1901, 16, 563.

² F. Osmond and G. Cartaud, *Rev. gén. des Sciences*, 1905, 16, 51.
A summary of work on the subject.

³ *Proc. Roy. Soc.*, 1903, 72, 227; *Electrochem. and Metall.*, 1903, 3, 806.

this should be prepared by levigation, as described by Le Chatelier.¹ Alumina, prepared by the ignition of ammonium alum, is ground with water in a mortar, or, better, agitated with water in a porcelain ball-mill in order to break up lumps. It is then washed several times with N/1000 nitric acid to remove soluble matter, being allowed to settle each time. When it is found to settle with difficulty, the nitric acid is replaced by distilled water, and the alumina is finally suspended in water containing 1-2 c.c. of strong ammonia per litre. The liquid with the powder in suspension is now sucked up by means of a filter-pump into a pipette holding about a litre (Fig. 55). The lower end of this pipette is sloped steeply as shown, in order to prevent adhesion of the deposit. The opening at the lower end should be about 2 mm. in diameter. The tap is now regulated so that a drop falls about every 12 seconds. All that issues in the first 15 minutes is rejected, since it consists of gritty particles, which are useless even after re-grinding. After this, the deposit formed in the next three hours may be collected, but it is still comparatively coarse and capable of producing minute scratches; it should therefore be used only for hard steels and similar substances. The suspended matter which issues in from 3 to 12 hours is fine, and is suitable for polishing brass, bronze, and, in fact, the majority of ordinary alloys. For the very finest work, alumina capable of remaining in suspension longer than 12 hours may be used. The yield, however, is exceedingly small, and in order to obtain such material large quantities of the crude substance must be treated. The simple apparatus described above is then replaced by an elutriation apparatus, as used in the physical examination of soils.²



FIG. 55.
Pipette for preparing alumina.

¹ *Rev. de Métallurgie*, 1905, 2, 528.

² Messrs. P. F. Dujardin & Co., Düsseldorf, supply these powders mixed with 3 to 5 parts of water, a little dye being added to distinguish the grades of fineness. Thus 3-hour alumina is coloured blue, 12-hour is colourless, and 24-hour alumina pink.

For very soft specimens, such as the alloys of tin and lead, the best results are obtained by polishing with chromium oxide, levigated as described for alumina, only the very finest portions being used.¹ Fine magnesium oxide is very convenient, and does not require any preparation.

The deposits obtained in the process of levigation should not be dried, but should be stored in the form of a thin cream with water in bottles with well-fitting rubber stoppers. In some laboratories the suspended alumina is precipitated by the cautious addition of dilute acid, and the precipitate mixed with shavings of Castille soap and warmed on the water-bath, so as to form a cream, which is then stored in the collapsible tin tubes used for artists' colours. The addition of soap gives good results in polishing steel, but produces undesirable effects in the case of many alloys, and the author prefers to dispense with its use.

For polishing purposes, it is necessary to distribute the powder on some support. Fine felt or cloth is generally used for this purpose. The texture must be close and uniform, and there must be no ribbed or raised pattern. Most samples of cloth will be found to scratch soft metals, even after washing thoroughly to remove gritty particles. The best quality is that known in the trade as "beaver" cloth. Good results are also obtained with a kind of velveteen sold for polishing purposes under the name of "selvyt," but this wears out more rapidly than a heavier cloth.

The fabric is tightly stretched over a hard surface, and for hand polishing may be conveniently attached to a support of glass or slate. The operation of polishing is, however, generally performed mechanically, the specimen being lightly held in the fingers against a rotating disc covered with fabric. On the small machine illustrated in Fig. 54, the cloth is stretched over a hard wooden cone, and clamped with a brass ring. A good plan, when using diamantine, is to clamp two thicknesses of selvyt on to the cone, diamantine powder being placed on the lower cloth. When thoroughly wetted, the finer particles of the powder work their way up through the fabric under the pressure of the specimen. Usually a larger disc is employed;

¹ W. Rosenhain and P. A. Tucker, *Phil. Trans.*, 1908, 209A, 89.

one 15 cm. in diameter, mounted on a vertical axis and driven by a leather or gut band by a treadle or motor, is very convenient (Fig. 56). The cloth is clamped on by means of a brass ring. In other forms of apparatus the disc runs vertically, two discs being mounted on the same horizontal axis. The disc should in either case be surrounded by a metal water-guard.

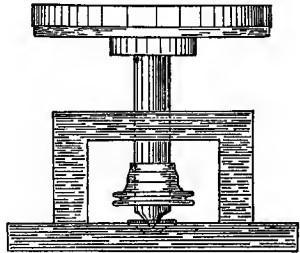

FIG. 56.—Simple polishing disc.

When dry powder is applied to a cloth surface, it should be thoroughly rubbed in with the finger, and a stream of water run over the surface to remove coarse particles. It is much better to apply the powder in the form of a fine suspension (containing 3 to 10 grams of solid per litre, according to the coarseness) by means of a spraying bottle fitted with jet and rubber bulb. The cloth is kept continually moist by the application of the spray. Great care must always be taken to keep the polishing cloth free from dust, and rubbing with the finger or a brush and washing should never be omitted on resuming work after an interval. A single particle of grit may score a specimen so badly as to necessitate re-grinding and re-polishing.

All polishing is carried out on a wet cloth. This is essential for microscopical work. The forced polish given by rouge on dry chamois leather is very attractive to the eye, but is useless for a surface which is to be etched. The machine shown in Fig. 54 is provided with a central water vessel, from which a small tap projects over each disc, by the regulation of which water may be made to drip regularly on to the surface of the cloth. The excess of water is thrown off by centrifugal force, is caught by the brass water-guards, and flows into a trough below the level of the discs. The water vessel is unnecessary when the spray is employed. Alloys which are attacked by water may be polished with a little light petroleum.

If the polishing powder cakes on the surface of the metal, it is a sign that the cloth is too dry. If allowed to continue,

“seizing” may take place, and it may be impossible to remove the powder without destroying the surface. With many metals a point is reached at which further polishing produces a diminution of the lustre, and the process should then be interrupted. Examination from time to time with a hand lens enables the operator to follow the gradual disappearance of the scratches. When finished, the specimen should present a uniform mirror-like surface under the microscope, unless either of the following conditions is present:—

1. The constituents differ markedly in colour. In copper-antimony alloys rich in antimony the structure is well seen on polishing without etching, as the compound Cu_2Sb , which is present as one of the constituents of the eutectic, is violet in colour, and outlines the antimony crystals with great distinctness. The same may be said of the alloys of aluminium and gold, the compound AuAl_2 (Roberts-Austen's purple alloy) being strongly coloured.

2. The constituents differ greatly in hardness. The hardest constituent may be found to present itself in relief, even when precautions have been taken to avoid wearing away the soft parts. Thus in polishing white bearing metals containing copper and antimony in a base of tin or of tin and lead, the hard needles of the copper-tin constituent will almost always be found to project above the soft matrix, and thus to be visible without etching.

3. The alloy is porous. Dark irregular patches are seen. Cavities in the specimen cause serious difficulties in polishing, since they readily retain particles of dirt, emery, or polishing material which may become dislodged in the subsequent process of polishing, and give rise to deep scratches. A porous specimen should therefore be thoroughly washed in a stream of water after each stage. When the cavities are coarse, as when defective castings or cracked specimens are under examination, it is advisable to fill them with a plastic material, such as shellac, before rubbing on fine emery paper.

However carefully the polishing process is conducted, the edges of the specimen will become slightly rounded. When, therefore, the examination of the structure right up to the edge

is important, as in the study of fractures, some means of preserving the edge must be adopted. The simplest plan is that of embedding in white metal. The piece of metal to be examined is immersed in a crucible of molten white metal (tin-lead-antimony alloy), and held in position by a wire until the alloy has solidified. The mass is then sawn through in the required direction, and the section thus obtained, in which the metal to be studied is surrounded and protected by white metal, is polished in the usual way.¹

More delicate detail, such as the fine step-like deformations of strained surfaces known as "slip-bands," may be protected by electro-plating with copper.² Steel specimens must first be thinly coated by a weak current in a copper cyanide bath, a thick plating then being applied in the usual acid sulphate bath, several days being necessary.

ETCHING

In general, further treatment is required to render the structure clearly visible. The means adopted are usually of a chemical nature, and depend on the different degree of attack of the separate micrographic constituents by reagents. It will be convenient to begin with liquid etching reagents, and to consider the various solutions in order.

Hydrochloric acid.—The concentrated acid is useful for many white metals, the basis of which is tin. The specimen is immersed in the acid for a few seconds, the process being watched with a hand lens. When sufficiently etched, it is removed, rinsed in water, lightly dried with a cloth, and examined.

Dilute hydrochloric acid is a convenient reagent for metals containing large amounts of tin, and also for steels in certain cases. An alcoholic solution, prepared by diluting 5 c.c. of concentrated acid to 100 c.c. with alcohol, is the most regular in its action. The specimen may be washed with alcohol, and

¹ See A. K. Huntington, *Trans. Faraday Soc.*, 1905, 1, 324.

² W. Rosenhain, *Proc. Roy. Soc.*, 1905, 74, 557; *J. Iron Steel Inst.*, 1906, ii. 196.

dried in a current of air. Alloys containing free zinc require a much more dilute acid.

Nitric acid.—The concentrated acid is used for metals which can only be attacked by its means. A method of etching formerly in favour for iron and steel was that of covering the specimen with concentrated nitric acid, which rendered the surface passive, and rapidly rinsing in a stream of water. The momentary action occasionally gave very good results, but it was not under control, and has been superseded by better methods. Nitric acid, D 1·2, is a more generally useful reagent. It etches phosphor-copper, copper-silver alloys, etc., very clearly, giving bold contrasts which are very suitable for photography. It may also be used for the deep etching of copper and its solid solutions. Dilute nitric acid was formerly the most general reagent for steels, a 1 per cent. or 5 per cent. solution being used. It gives good results in the rough work of workshops, when fine detail is not required, but is apt to cause much irregular "pitting." A 4 per cent. solution in amyl alcohol has been employed for steels, but has the disadvantage that the coloured films produced by it vary in tint in different parts of the same specimen. It serves to distinguish austenite from martensite. Still better results were found to be given¹ by a complex solution consisting of equal parts of amyl alcohol, ethyl alcohol, methyl alcohol, and of a 4 per cent. solution of nitric acid in acetic anhydride, mixing just before use. The action of solutions in mixed alcohols is very different from that of solutions in either alcohol alone.

Picric acid.—This reagent, introduced by Ischewsky,² is by far the most generally useful for steel. A saturated alcoholic solution is employed. The etching is very regular, without pitting, and good photographic contrast is obtained. Since the coloration produced by this and similar reagents is due to the deposition of adherent films of carbonaceous matter, the specimens should be washed with alcohol and dried by air without wiping. Ether may be used to hasten drying. A

¹ W. J. Kurbatoff, *Rev. de Métallurgie*, 1905, 2, 169; 1906, 3, 648.

² *Stahl u. Eisen*, 1903, 23, 120.

4 per cent. solution of picric acid in amyl alcohol acts still more slowly and uniformly.

*Cupric ammonium chloride*¹ has been used for steels and for copper, and an alcoholic solution of *iodine* for many metals, but neither solution is indispensable.

Ammonia gives good results with copper alloys, especially with those of copper and zinc. Exposure to air is required, so that instead of immersing the specimen, it is better to apply the solution (1 : 3) by rubbing lightly with the finger-tip or a plug of cotton-wool. The development of structure is easily followed. Immersion in ammonia to which hydrogen peroxide has been added is less satisfactory.

Sodium or potassium hydroxide is employed for alloys containing an excess of zinc or aluminium.

Sodium picrate, prepared by adding a cold saturated aqueous solution of picric acid to a 50 per cent. solution of sodium hydroxide, is the only reagent which blackens cementite (Fe_3C). The solution is kept boiling, and the specimen is immersed in it for 5 minutes.

Ferric chloride.—This reagent, employed with great success by Heycock and Neville in their study of the copper-tin alloys,² which includes some of the most beautiful photomicrographs yet produced, is generally useful for bronzes. It is prepared by adding a syrupy solution of ferric chloride to concentrated hydrochloric acid, and diluting with water, the correct dilution having to be found by trial. Like ammonia, it is apt to develop latent scratches, and a specimen presenting an excellent polish may therefore appear badly scratched after etching.

Aqua regia is necessarily employed for many alloys of gold and of the platinum metals. It is generally necessary to raise it to a temperature just below its boiling-point.

Of other complex solutions, a mixture of 3 vols. of a saturated alcoholic solution of *o*-nitrophenol and 1 vol. of a

¹ E. Heyn, *Verh. Ver. Bef. Gewerbevereines*, 1904, 235. A comparison of the reagents for steel will be found in Goerens, *Erstarrung und Umwandlungen von Eisenkohlenstofflegierungen*, Halle, 1907.

² *Phil. Trans.*, 1903, 202A, 1.

4 per cent. alcoholic solution of nitric acid has been found to give excellent results with hardened steels.¹ Another reagent, distinguishing clearly between the constituents of steels quenched from a high temperature, is a 5 per cent. alcoholic solution of *m*-nitrobenzoic acid,² whilst a dilute solution of sulphurous acid, which causes severe pitting in ferrite, has been found useful in the examination of hardened steels.³

The reagents enumerated are the most important, but many others find application for special purposes, and a consideration of the chemical characteristics of the alloy under examination will usually suggest the reagent to be employed. Potassium cyanide is useful as a means of removing the tarnished films produced in the etching of copper alloys.

Electrolytic etching.—It is often convenient to assist the etching process by means of an electric current, the specimen being made the anode in a solution of an electrolyte. This may be ammonium nitrate or any other neutral salt. Le Chatelier⁴ obtained the best results with copper-tin alloys by using sodium thiosulphate. Ammonia may be used for copper alloys. The solution is placed in a beaker, and the specimen supported below the surface by a bridge of platinum wire or foil, a second piece of platinum foil being employed as cathode. The source of current is a dichromate cell or small accumulator, a sufficient resistance in the form of wire being interposed. Strong currents, up to 1 amp., have been used in certain cases, but generally a very small current, 0.01 amp. or less, is sufficient. The process may be interrupted from time to time in order to examine the etched surface.

Heat-tinting.—When heated in the air, many metals and alloys become coated with a film of oxide, which remains adherent and shows the colours of thin films. Since different constituents oxidize with unequal rapidity, Stead⁵ has based

¹ W. J. Kurbatoff, *Rev. de Métallurgie*, 1905, 2, 169; P. Breuil, *Bull. Soc. Ind. min.*, [iv.] 6; *Métallurgie*, 1908, 5, 59.

² C. Benedicks, *J. Iron Steel Inst.*, 1908, ii. 237.

³ S. Hilpert and E. Colver-Glauert, *J. Iron Steel Inst.*, 1910, ii. 54.

⁴ *Bull. Soc. d'Encouragement*, 1896, [v.] 1, 559; *Etude des Alliages*, 63.

⁵ *J. Iron Steel Inst.*, 1900, ii. 137.

on this fact a very delicate method of distinguishing between certain of the constituents of iron and steel. The specimen is best embedded in sand on a metal plate or in a porcelain capsule, and heated with a small flame until the colours appear. The oxidation can be stopped at any required point by plunging into mercury. To obtain successful results, the surface of the specimen must be thoroughly clean and dry, as the presence of moisture in cavities of the metal causes the formation of irregular coloured rings. It is advisable to heat the specimen, previously freed from grease, to 120° , and then to rub on clean, warm flannel, before heating to a higher temperature. Very regular heating is required, and as it is of great advantage to keep the surface under observation throughout, Stead has devised an electrical heater, by means of which the heat-tinting can be carried on on the stage of the microscope without injury to the latter. This device is shown in Fig. 57. Two brass plates, provided with binding screws, are fixed on an ebonite stage plate, with a circular opening to receive the heating vessel. This is a porcelain capsule, partly filled with a plastic magnesia mass, on which a flat spiral of platinum wire is laid, and fixed with a mixture of silica

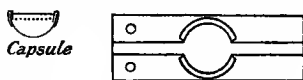

FIG. 57.

and sodium silicate, with which it is lightly covered. Two brass strips form the terminals of the spiral, and serve to make contact with the brass supports. The hemispherical capsule can be freely tilted for the purpose of levelling the surface of the micro-section, and the non-conducting nature of the magnesia prevents the heating of any part of the microscope. By suitably regulating the current, the heating is kept under perfect control.

This method gives remarkably beautiful results with steel, cast-iron, and certain copper alloys, especially those containing antimony or silver. As an example of its use, the effect of heating steel or iron containing phosphorus¹ may be mentioned. At 280° , the carbide of iron, cementite, becomes reddish-brown. The phosphide becomes pale yellow in 10

¹ Stead, *loc. cit.*

minutes, salmon in 15, and on further heating assumes a characteristic (heliotrope) shade of blue.

Coloured films may also be produced by the action of iodine, bromine, or hydrogen sulphide on alloys, the dry vapour being led, mixed with air, into a glass vessel containing the specimen, warmed if necessary. Surface tinting has certain advantages over etching, since none of the metal is removed, and a flat surface remains, which is readily exposed again by a momentary re-polishing. It is often useful to produce an oxidation-film on a specimen, and after noting the appearance or recording it by photography, to develop the structure by etching, a comparison of the two observations giving results of considerable value.

Polishing in relief.—By polishing with rouge on a soft bed, such as chamois leather or parchment, the hard constituents of an alloy may be made to appear in relief. This method is less employed now than in the early days of metallography, when the choice of etching reagents was more limited. A certain amount of sharpness of outline is inevitably lost when a specimen is polished in relief, since the projecting crystals are always to some extent rounded at the edges by the friction. The method gives useful information in certain cases as to the wearing quality of a metal intended for use in bearings, etc., since it shows the quantity and distribution of the hard particles in the soft ground-mass. For all other purposes, the attack by reagents is to be preferred.

Polish-attack.—A method devised by Osmond¹ consists in combining the polishing process with one of selective colouring with a reagent. The fact that many workmen use an aqueous extract of liquorice root, known as *coco*, for colouring steel, suggested the use of this preparation. A piece of wet parchment is fastened to a board, and fine rouge or precipitated calcium sulphate is rubbed into its surface, all but the finest particles then being removed by washing. The specimen is then polished very lightly, keeping the parchment moistened with the liquorice extract. After a short time, the steel becomes selectively attacked, and the structure is very clearly developed.

¹ F. Osmond, *Étude des Alliages*, 1901, 277.

The use of a vegetable extract of uncertain composition having many disadvantages, Osmond made experiments with various inorganic salts, and found that a 2 per cent. solution of ammonium nitrate gave equally good results, and was more rapid in its action. The extract of liquorice probably owes its activity to the presence of similar salts.

This method has been especially successful in the hands of its inventor, and the beautiful photo-micrographs of pearlite (the finely laminated alternating growth of iron and iron carbide found in steels, see Chapter XVII.) prepared by him, and frequently reproduced by other writers, were obtained by its means. For the ordinary examination of steels, it has been practically superseded by the picric acid method. Le Chatelier¹ has obtained good photographs of grey cast-iron by rubbing the surface lightly with an alcoholic solution of iodine. The beneficial effect of gentle friction in etching copper-zinc alloys with ammonia is also very marked.

It has been proposed² to deposit a thin layer of metal on the polished surface, the different electrochemical character of the various micrographic constituents causing selective deposition. The section is either made the cathode in an electrolytic cell, or is simply immersed in a solution of a metallic salt, the local couples formed on the surface being then sufficient to cause deposition. The method has been utilized to develop the "cores" in solid solutions in a state of imperfect equilibrium. Thus, on immersing a polished specimen of unannealed tin bronze containing 16 per cent. Sn and 84 per cent. Cu in a 10 per cent. solution of copper sulphate for 15 seconds, dark cores are seen in the crystals of the solid solution. The results are, however, inferior to those obtained by heat-tinting or by etching with a suitably chosen reagent.

PREPARATION OF A SMOOTH SURFACE WITHOUT GRINDING OR POLISHING

The great difficulty experienced in grinding soft metals and alloys has led some investigators to devise other means of

¹ *Étude des Alliages*, 421.

² F. Giolitti, *Gazzetta*, 1906, 36, ii. 142; 1908, 38, ii. 352.

obtaining a smooth surface. In experiments on the deformation of lead, Rosenhain¹ prepared a clean surface of the metal by scraping, and levelled this surface by pressing heavily against plate glass. On subsequent annealing in a sealed glass tube, a perfectly smooth surface was obtained, on which the lines obtained by deformation could be accurately studied. This method is, of course, only applicable when the metal is to be annealed after the pressure.

Many investigators have used cast in place of cut and polished surfaces. The examination of the upper surface of a bead or ingot² or of the under side of a crust obtained by pouring off the still liquid portion of an alloy³ gives interesting information as to the growth of a crystal; but such an examination naturally supplements the study of polished sections rather than replaces it. Alloys of comparatively low melting-point may be cast on a surface of glass⁴ or mica,⁵ or a heated sheet of one of these materials may be slid over the surface of a small crucible filled with the molten alloy. The structure thus revealed, although often very distinct, does not necessarily correspond with that in the interior of the mass. Curious effects are sometimes produced by the escape of gas at the moment of solidification, causing the inclusion of bubbles between the metal and the glass, these bubbles taking the form of negative crystals.

The improvements which have been made in recent years in the processes of grinding and polishing soft metals have rendered these substitutes almost superfluous, except when it is specially desired to study the cast surface.

The preservation of polished and etched specimens is a matter of some difficulty. The usual method of preserving microscopical preparations, by affixing a cover-glass with Canada balsam, is not available, as the presence of the cover-glass interferes with the subsequent examination under vertical

¹ *J. Iron Steel Inst.*, 1904, i. 346.

² W. Campbell, *Metallurgie*, 1907, 4, 801, 825.

³ J. C. W. Humfrey, *Phil. Trans.*, 1902, 200A, 225; N. S. Kurnakoff and N. A. Pushin, *Zeitsch. anorg. Chem.*, 1907, 52, 430.

⁴ J. A. Ewing and W. Rosenhain, *Phil. Trans.*, 1900, 193A, 353.

⁵ H. J. Hannover, *Bull. Soc. d'Encouragement*, 1900, [v.] 6, 210.

illumination, causing scattering of light and "flare." The surface may be coated with a thin layer of a solution of nitrocellulose in amyl acetate. The film thus obtained is very thin, and may be removed if necessary just before examination, by washing with the solvent. The most generally satisfactory plan is that of heating the specimen in an oven to near 100°, and packing in a labelled glass tube containing warm, dry cotton-wool. All specimens are most conveniently stored in an unmounted condition. Heat-tinted sections retain their appearance well.

Sections in an unpolished condition may be stored in the small envelopes, about 3 cm. square, used by gardeners for collecting seeds.

CHAPTER VIII

THE MICROSCOPICAL EXAMINATION OF PREPARED SECTIONS

ALTHOUGH several special types of microscope, each possessing some advantages, have been designed for the purpose of examining the structure of alloys, it is quite possible to obtain satisfactory results with any microscope of good mechanical construction. Since metals and alloys, being opaque, are necessarily examined by reflected light, the substage, condensers, polarizing prisms, and other appliances which add greatly to the cost of a good microscope, may be dispensed with, whilst certain special illuminating devices are required in their stead. It is nevertheless true that a microscope, designed with a view to its employment in metallographic work, offers far greater convenience, especially when a large number of different sections have to be examined in rapid succession. The beginner, however, who possesses a fairly good ordinary microscope stand, need not be deterred by his lack of the elaborate appliances described in the makers' catalogues, and in the following account of the microscopical equipment employed in metallography, his requirements will be kept in view.

The principal modification found in metallographic microscope stands is the provision of means for raising and lowering the stage. The reason for this arrangement is, that when the object is illuminated by means of a device inserted in the tube of the microscope, as described below, it is convenient to fix the position of this illuminator once for all, so that it always occupies the same position relatively to the source of light.

When, owing to the use of an objective of different working distance, or to the introduction of metal sections of different thickness, it is required to vary the distance between the stage and the front lens of the objective, it is convenient to effect this by racking the stage up or down, leaving the body-tube, in which the illuminator is placed, untouched. But even this modification, although undoubtedly effecting a great saving of time and trouble, is not indispensable for accurate work, and means will be described below for dispensing with it.

Since the principal source of difference between metallographic and ordinary microscopical manipulation lies in the illumination of the specimen by reflected, instead of by transmitted light, it will be convenient to commence the description of the appliances used with the illuminator.

In the simplest method, a beam of light is allowed to impinge on the surface of the section at an oblique angle, as in Fig. 58. With a truly plane surface, the whole of the beam is reflected as by a mirror, and passes entirely out of the field of the objective.

To an eye placed at the end of the microscope tube, therefore, the surface of the metal appears perfectly black, none of the reflected rays being received by the eye. Should the specimen be etched, however, the surface will not be plane,

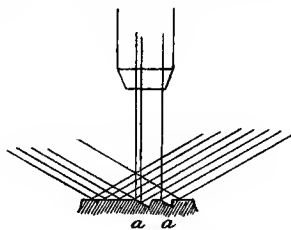

FIG. 58.

but will present a number of elevations or depressions, composed of intersecting crystal faces. Suppose that some of these faces, as at *a, a*, have such an inclination to the surface as a whole that the rays which they reflect have a vertical direction. These rays will enter the microscope, and the areas *a, a* will consequently appear bright. In an etched portion of the specimen, there will usually be numerous small facets having the required inclination, and the etched area will therefore appear to be irregularly illuminated, and to have a granular appearance, owing to its roughness. On the other hand, those areas which have not been attacked by the etching reagent

retain their original smoothness, and since they reflect the incident beam outside of the field of the objective, they present the appearance of dark areas on a light background. The appearances presented by sections under this form of illumination are often difficult to interpret, and are apt to mislead those who have not considerable metallographic experience. For this and other reasons, amongst which the great loss of light is the chief, oblique illumination is of only limited utility; it is, however, indispensable for certain kinds of investigation, as in distinguishing the true nature of slip-bands, etc. When it is to be employed, the beam of light is concentrated on the object at a suitable angle by means of a bull's-eye condenser, the position of the condenser being so chosen that the area of illumination is as uniform as possible. The parabolic reflectors formerly used for this class of work are only of limited use, and need not be described. When grazing incidence is required, an Amici prism (a small triangular prism, of which two faces are convex) is convenient.

The majority of metallographic sections are best examined under vertical, or nearly vertical, illumination. This necessitates the introduction of a beam of light into the tube of the microscope above the objective, this beam being then deflected so as to pass through the objective, and after reflection from the surface of the metal, to retrace its path, passing up the body-tube of the microscope to the eyepiece end. Two different types of illuminating device have been employed for this purpose. In the first, known as the Beck vertical illuminator, a thin plate of glass, with parallel surfaces, is placed at an angle of 45° to the optical axis, as shown in Fig. 59. The rays from the source of light, entering the tube in the direction AB, are in part reflected from the surface of the glass plate, and pass downwards in the direction BC. The rays reflected from the object travel back in the direction CBD, passing through the glass plate on the way. It will be seen that a considerable loss of light is unavoidable on this system. Only a part of the beam AB is reflected downwards, the remainder passing on in the direction BE and being lost, and, in a similar manner, only a part of the returning beam passes through the plate without

change of direction, the remainder being reflected from the face, and passing uselessly out of the tube towards the source of light. In spite of these disadvantages, the Beck illuminator is generally to be preferred, as being less liable to produce false or distorted images than any instrument in which, as described below, only a part of the objective is illuminated. It is not essential that the small plane reflector should be optically worked so that its two faces are truly parallel. An ordinary thin microscopic cover-glass, tested for flatness, gives perfectly satisfactory results, and has the merit of cheapness. If too thick, defects due to astigmatism are produced.

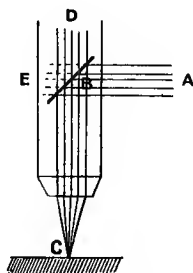

FIG. 59.

The Beck illuminator, as ordinarily constructed, has the defect that the whole aperture of the objective is not utilized, as the turning of the plate into a plane inclined to the axis at 45° causes its projection to become an ellipse. It would be an advantage to use a reflector so large that when inclined the whole of the back lens of the objective is covered by it. This pattern has been employed in Swift's microscope, designed by Jackson and Blount, and in an illuminator designed by Johnstone Stoney, and made by Watson. The arrangements for tilting, and for admitting the illuminating beam obliquely, in the latter instrument are, however, not advantageous, as false effects are thereby liable to be produced in the image.

For use with very low powers, where the working distance between lens and object is great, a large square cover-glass, mounted on a hinge, may be placed *below* the objective, as suggested by Stead.¹

In the second form of vertical illuminator, the thin glass plate is replaced by a small right-angled prism, giving total reflection. Since the prism necessarily blocks out a portion of the beam, it is necessary to arrange it so that only one half of the area of the tube is thus occupied. The reflected ray, after

¹ *J. Iron Steel Inst.*, 1897, i. 42.

passing twice through the objective, returns through the other half of the tube, passing at the back of the prism, as shown in

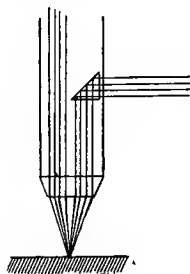

FIG. 60.

Fig. 60. The prism is capable of a certain amount of rotation, by which the inclination of the incident light may be changed within certain limits. In the Nachet form of illuminator, a traversing movement is also provided, allowing the prism to be moved nearer to or farther from the centre of the microscope tube. This adjustment is undesirable, displacement in this direction causing considerable distortion of the image, and consequent uncertainty as to the true meaning

of apparent structures observed. In the Zeiss form, diaphragms of different shapes are provided for cutting off the marginal rays, whilst the provision of an iris diaphragm between the illuminator and the objective is common to many forms of apparatus supplied by different makers. Although an apparent improvement in definition is often obtained by such means, the increased clearness is sometimes obtained at the cost of the truth of the image. It is always better to cut down the illuminating beam *before* entering the microscope, by means of suitable diaphragms placed between the source of light and the vertical illuminator.¹

In one form of illuminator supplied with the Rosenhain microscope made by Messrs. Beck, the reflector takes the form of a silvered half-disc, inclined at an angle of 45° . The mode of action of this apparatus exactly resembles that of the prism. A further modification of the prism, by which the central bundle of rays is utilized, is described below in connection with the Reichert microscope.

Whatever be the construction of the vertical illuminator, the prism or disc is enclosed in a short tube which screws into

¹ The great superiority of the plane plate illuminator over any form which utilizes only a portion of the bundle of rays entering the apparatus is shown by a comparison of the efficiency of the two forms in rendering fine detail. C. Benedicks, *Metallurgie*, 1909, 6, 320.

the lower end of the microscope body-tube, the objective, again, screwing into it. The illuminator must be capable of rotating freely about its axis without unscrewing. This movement, together with the movement of rotation of the reflector about the transverse axis, provides the means of adjustment of the incident light. In order to avoid internal reflections, which give rise to loss of light and to "flare," the distance between the reflector and the back lens of the objective should be as short as possible, nosepieces should therefore be dispensed with, the slight extra trouble thereby necessitated in changing objectives being more than compensated for by the better optical results obtained.

The introduction of the vertical illuminator increases the distance between the lower end of the body-tube and the stage very considerably, and with the short limb possessed by many stands, it will often be found, when working with low-power objectives, especially with low-power apochromats, which have very long mounts, that the tube has been racked up to its furthest limit before focus is obtained. A microscope specially constructed for metallography should therefore have a specially long limb. With an ordinary small microscope, the difficulty may sometimes be overcome by placing the specimen to be examined *below* the stage, attaching the glass slide by means of rubber bands, and viewing the surface through the central opening of the stage, thus securing an increased working distance. If the microscope has a racking sub-stage, this may very conveniently be employed as a stage with simple attachments which will readily suggest themselves. By such devices as these, satisfactory results may be obtained with an instrument such as is to be found in any laboratory.

The next fitting to be considered is the stage. Since metallographic specimens are only ground flat on a single surface, they are often otherwise irregular in shape. In order to examine them, it is necessary to set the flat polished surface accurately perpendicularly to the optical axis. Most metallogical microscopes were formerly fitted with tilting or levelling stages for this purpose, the specimen being mounted with sealing-wax or cement on a glass slip, which is then tilted

mechanically until all parts of the surface remain in focus when the slide is moved in any direction on the stage. Adjustment by means of a levelling stage is, however, tedious, and is rendered entirely unnecessary by the adoption of a simple device due to Stead. This consists in mounting the specimen in such a way that the surface to be examined is accurately parallel with that of the glass slip. On placing the slip on the stage, and holding it in the usual way by means of clips, this parallelism is retained, and no further adjustment is needed. For this method of mounting, the only apparatus required consists of a number of rings, cut from a piece of brass tube about 3 cm. diameter, of widths varying from 4 mm. to 16 mm., the edges being accurately parallel. Such rings are readily cut on a

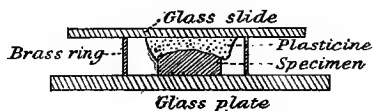

FIG. 61.—Mounting device.

lathe. The micro-specimen is laid, with the smooth surface downwards, on a sheet of glass, and a ring of suitable height placed over it. A small quantity of plasticine (a plastic material used for modelling purposes, which may be used indefinitely without becoming hard) is placed on the specimen, and an ordinary glass micro-slip is pressed down until it is in perfect contact with the brass ring (Fig. 61). The slip, with the specimen now adhering to it, is lifted, turned over, and placed on the microscope stage, and requires no further levelling. Instead of using a series of rings of varying thickness, mechanical mounting devices have been used, on the principle of the well-known botanical microtome,¹ or of the Rousselet compressorium.² The construction will be obvious to any one acquainted with microscopical apparatus, but the cheap and simple device described above will be found equally satisfactory in all respects.

¹ J. E. Stead, *J. Iron Steel Inst.*, 1897, i. 42.

² W. Rosenhain. Apparatus made by Messrs. Watson.

The provision of mechanical movements to the stage, and of means for rotating it, greatly adds to the convenience of the worker, and the former is in fact indispensable when working with any but low powers. Rotation is necessary when observing structures under oblique illumination. The mechanism does not differ from that employed in microscopes intended for observations by transmitted light. A large, roomy stage, free from projections, is convenient when a variety of specimens have to be dealt with.

In laboratories in which a large number of specimens have to be examined, especially if photo-micrographs are to be taken, it is of advantage to use a stand which is designed with a view to metallographic work. For photographic purposes, the horizontal position is to be preferred to the vertical, on account of the greater rigidity and freedom from vibration, as well as for the increased convenience and comfort of the observer. The first instrument of this kind was that devised by Martens for use in the Charlottenburg laboratory.¹ This form is the parent of several later instruments, including that of Messrs. Watson (Fig. 62). The focussing, as in all these special forms of microscope, is effected by racking the stage and not the body-tube. The fine adjustment, however, is in most forms attached to the body-tube in the ordinary way. An entirely different construction was adopted by Le Chatelier,² in whose instrument the specimen under examination is placed face downwards on the stage, the illuminating beam entering through a horizontal collimating tube, and being reflected upwards by a totally reflecting prism into the objective, a second prism directing the reflected beam into the tube containing the eyepiece. The same principle has been adopted in the new microscope by Messrs. Reichert,³ a diagrammatic section of which is shown in Fig. 63. The defects of the

¹ A. Martens and E. Heyn, *Mitth. k. techn. Versuchs-Anst.*, 1899, 17, 73. This paper contains a full description of the Charlottenburg equipment, and a valuable discussion of the best optical conditions.

² H. Le Chatelier, *Étude des Alliages*, 1901, 421. This instrument is made by Messrs. Pellin, Paris.

³ See the description by O. Heimstädt, *Metallurgie*, 1909, 6, 58.

ordinary illuminating prism are in this instrument partly overcome by the use of two right-angled prisms cemented together to form a cube, P. The upper prism is silvered over an elliptical area, as shown by the central dark line. The rays entering the instrument from the mirror M pass through the glass cube in the form of a hollow cylinder of

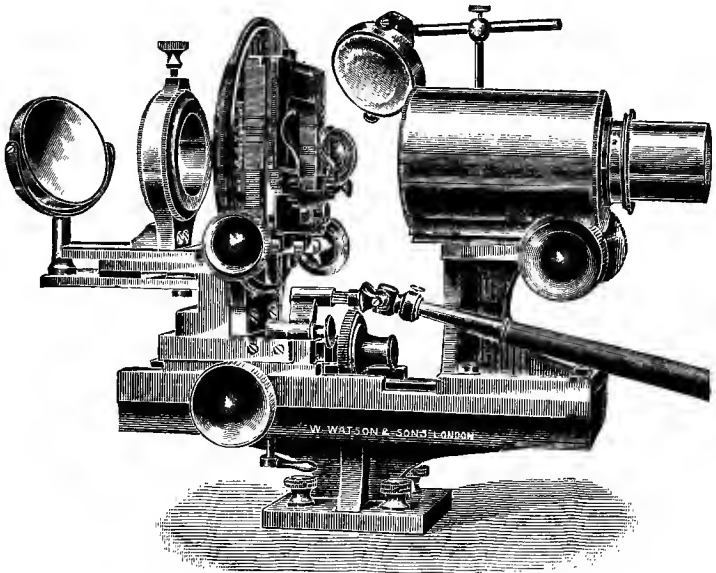

FIG. 62.—Horizontal microscope for metallography.

circular section and so enter the objective. The surface of the specimen S is thus illuminated by an oblique cone of light, and the rays from a central bundle are reflected by the silvered ellipse so as to pass into the observing tube O. This arrangement, by providing for conical instead of one-sided illumination, partly avoids the exaggeration of the spherical aberration defects of the objective, noticed when an ordinary vertical prism is used. It is, however,

liable to the objection already urged against all devices in which only a portion of the illuminating beam is employed, namely, that it is liable to give a false rendering of fine detail.

The Rosenhain metallurgical microscope (Fig. 64) is so constructed as to have great rigidity when used in a horizontal position. The usual construction of the stand is departed from widely, and the massive girder-shaped limb, fitting into a shaped portion of the heavy triangular base, removes all risk of displacement by shaking. The stage is

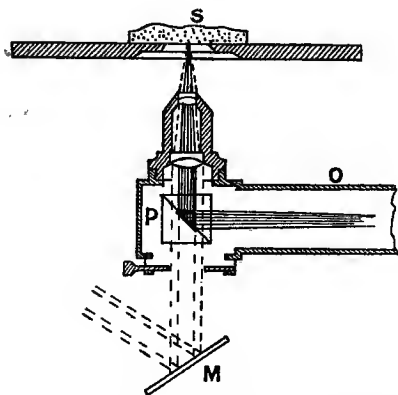

FIG. 63.—Reichert's modification of Le Chatelier's microscope.

fitted with both coarse and fine adjustments for focussing, and there are numerous minor modifications for facilitating illumination.

The objectives to be used in metallographic investigations require careful selection. Since metallic specimens are examined without a cover-glass, which would cause excessive surface reflection and consequent loss of clearness, all objectives should be corrected for uncovered objects. Further, in order to avoid internal reflections, the back lens of the objective should be as close to the vertical illuminator as possible, and it is therefore advisable to have special short

mounts, which have the additional advantage of reducing the height to which the body-tube has to be racked up. Several

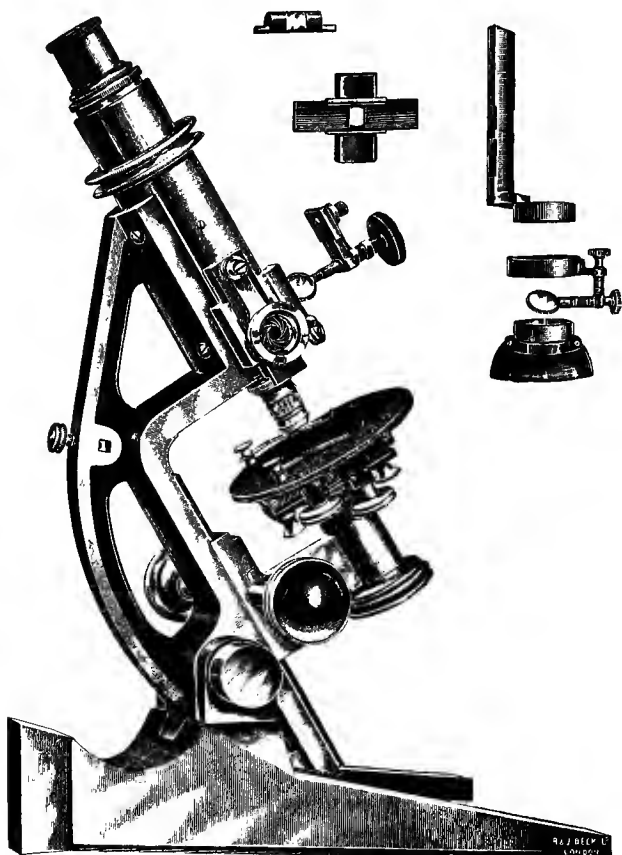

FIG. 64.—Rosenhain microscope.

of the leading makers now supply such objectives, in short mounts, and corrected for uncovered objects.

The most useful powers for metallographic work are 25, 16, 6, 4, and 2 mm., with a low power such as a 50 mm. for

very coarse structures. To obtain the best results, apochromats should be used. Good achromatic objectives are much less expensive, and are quite satisfactory for ordinary routine observations; but when photographic records of fine detail have to be made, the superior performance of the apochromats will be found fully to justify their increased cost. Apochromats do not, however, give such a flat field as achromatic lenses. For high-power work, an oil immersion objective must be used. The results obtained are apt to be disappointing at first, but the lens is not entirely responsible for this, as it is very difficult to prepare the specimens with a sufficiently good surface to bear the high magnification. For work of the highest class a lens of large aperture, such as Zeiss's 2 mm. apochromat of ap. 1.4, should be employed. It must be remembered that such an objective as this requires careful handling, on account of the very high curvature of the lens, which is only held in its mount by a shallow groove. Messrs. Swift also construct a lens suitable for the purpose. There is sometimes an advantage in using immersion, even for a lower power, on account of the superior light-gathering power and increased working distance. A $\frac{1}{8}$ in. (4 mm.) immersion lens is made by Messrs. Beck for this purpose.

Nosepieces should be avoided, as they increase the distance between the illuminator and the back lens of the objective, and so cause liability to flare. The improvement in the performance of the objectives more than compensates for the slight additional time occupied in changing objectives. It may also be necessary to insert a lining of thin velvet or black paper in the lower part of the body-tube to lessen reflection.

Ordinary Huyghenian eyepieces are used with achromatic objectives; but the specially designed compensating eyepieces should always be used with apochromats to utilize their advantages fully. The eyepieces should be of low or medium power, as the loss of light in metallographic examinations is so great that a high-power eyepiece gives a very dimly illuminated field. A number 2 eyepiece will be found the most convenient for ordinary routine work. When the apparatus is arranged for photography, an eyepiece may be dispensed with, although

it will then be found difficult to avoid a slight central flare, so that a projection eyepiece is almost indispensable. This is an eyepiece of low power (the $\times 2$ is the most generally useful) in which the lower lens produces an image in the plane of the diaphragm, which is then magnified by the upper combination. In order to focus this image, the tube holding the upper combination may be moved in and out, revolving in a helically cut slot. The position is indicated on the cap by a pointer travelling round a dial (Fig. 65). When projecting on to a screen, this part of the eyepiece tube is moved until the image of the diaphragm appears perfectly sharp on the screen. The position of the lenses in the eyepiece depends on their distance from the screen.

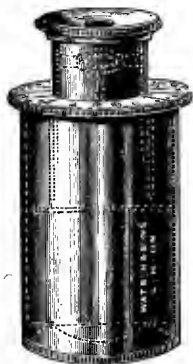

FIG. 65.—Projection eyepiece.

Either electric light or gas may be used as an illuminant. Where the apparatus is fitted up in a permanent manner, it is advantageous to use the electric arc, on account of the great intensity of the light, which reduces the length of exposure necessary in photographing sections, and facilitates working with high magnifications or with surfaces of low reflecting power. If an automatic arc be used, the regulating mechanism should be very sensitive, so as to maintain a steady arc of uniform intensity. The large Schuckert lamps supplied by Zeiss fulfil this condition. The carbons should be as free as possible from ash to avoid irregular sputtering. Siemens' A carbons, cored positives and solid negatives, are suitable. When a perfectly steady automatic arc is not available, it is better to use a hand-feed arc lamp than one with an irregular and unsteady regulating mechanism. With a little practice, it is not difficult to maintain a steady illumination with a hand-feed lamp of the kind supplied by several makers for lantern purposes.

Next to the arc lamp in convenience, and surpassing it for the worker who has only an ordinary domestic lighting current

available, comes the Nernst lamp with incandescent filament, which may be obtained for any usual voltage. The lamp is placed horizontally, the filament also having a horizontal direction, and the glass globe is removed. The narrowness of the luminous source makes it somewhat difficult to fill the objective uniformly with light, but this may be overcome by a suitable arrangement of the condensing lenses, the image of the filament being thrown slightly out of focus. A lamp with several parallel filaments is more convenient.

The mercury arc has also been used¹ as a source of light. The Nernst lamp will, however, be generally preferred.

A gas lamp with incandescent mantle is a very convenient source of light for visual observations, and may also be used for photography, although it involves a longer exposure than when electricity is available. A gas flame without mantle is useless.

Martens has employed an oxygen-coal gas flame, directed on to the end of a thin cylinder of magnesia (the rod used as support for an incandescent gas mantle) so that the actual source of light is a very small round disc. Precautions are necessary in regulating the combustion so as to maintain uniformity,² and the arrangement is not likely to be adopted in ordinary laboratories.

For visual observations, when very intense illumination is not required, a small glow-lamp may be attached to the illuminator in a fixed position, thus obviating the necessity of an optical bench or even of a condensing lens, and rendering the entire apparatus portable. This arrangement has been adopted in two instances. Messrs. Pellin construct a modified Le Chatelier microscope in which the lamp is held in a tube at right angles to the fitting containing the illuminating prism. The stage is of the usual racking type. In Stead's workshop microscope,³ there is no stage, the

¹ H. Le Chatelier, *Étude des Alliages*, 1901, 421.

² A. Martens and E. Heyn, *Mitth. k. techn. Versuchs-Anst.*, 1899, 17, 73.

³ *J. Iron Steel Inst.*, 1908, iii. 22. The instrument is made by Messrs. Swift and Son.

vertical tube being supported by a tripod, so that it may be applied to a large mass of metal, such as a forging, a small area only being cleaned and polished. The illuminator is a plane-parallel plate of glass fixed above the objective, and a small 4-volt lamp, fed by an accumulator, is held in a tube at right angles to the optical axis.

When a portable microscope is not used, the microscope stands at a greater distance from the source of light. With a large illuminating surface, such as that of a Welsbach mantle, a simple bull's-eye condenser may be used, mounted on an adjustable stand, the flat side of the lens being turned towards the microscope. This gives ample light, and the adjustment

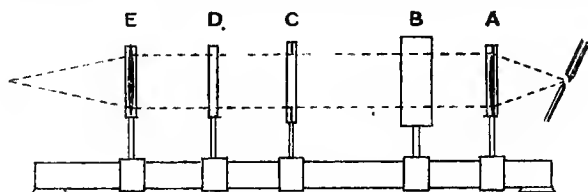

FIG. 66.—Optical bench.

necessary to obtain a field of uniform brightness is very simple.

With an arc or Nernst lamp, giving a very localized source of great intensity, a more elaborate arrangement is necessary. In order to effect the centring of the lenses, diaphragms, etc., employed, some form of optical bench is desirable, on which the fittings may be made to slide. The necessary fittings for a complete equipment are: two condensing lenses, an iris diaphragm, a water-trough for absorbing heat rays, and a colour filter for obtaining approximately monochromatic light. All of these should be supported on saddles of similar form, so as to be readily interchangeable in position.

The most suitable arrangement of the fittings is shown diagrammatically in Fig. 66. The lens A, of about 16 cm. focus, converts the rays from the arc or Nernst filament into a parallel beam, which passes through the water-trough B and the iris diaphragm C to the second lens E, which focusses the

image of the source on to the surface of the specimen. The apparatus having once been set up in position, it is only necessary to vary the position of E until the field of the microscope is of uniform brightness. D is a stand for holding colour filters. Of these the most generally employed is the Zettnow liquid filter, a 1 cm. layer of a green solution composed of 160 g. cupric nitrate, and 14 g. chromic acid, dissolved in 250 c.c. water. The Gifford screen is rather more convenient, consisting of a solution of malachite green in glycerol, together with a slip of bluish green glass. It is better, however, to use a series of colour-filters of known absorption, each of which transmits a definite section of the spectrum. By inserting one or more of these in the path of the rays, the contrast may be considerably heightened, with corresponding advantage to the clearness of the image. Such screens are made in gelatin, cemented to glass, by Messrs. Wratten and Wainwright, the A, B, and C screens giving a sufficient range of colours for all ordinary purposes, whilst the K 3 screen may be used when it is required to render a coloured surface, such as that of an alloy which has been heat-tinted, in its true ratio of luminosities.

The alignment of the fittings is preserved by the form of the bar forming the base of the optical bench, which has a triangular or trapezoidal section. Each fitting is as a rule provided with a means of vertical adjustment. Centreing should be performed with the iris diaphragm narrowed down to a small opening.

When an optical bench is not available, it is still possible to obtain a satisfactory illumination with simple means. Thus, with a Nernst lamp, an ordinary lantern condenser may be used in place of the lens A, and a bull's-eye condenser in place of E. The iris diaphragm may be replaced by a series of circular stops cut out of blackened card. More trouble is of course needed in centreing the parts, owing to the absence of adjusting devices, but accurate centreing is quite possible. The parts, once placed in alignment, should be attached to a wooden base-board to maintain their relative positions.

The disposition of the parts of the apparatus hitherto

described is the same, whether the microscope is to be used horizontally or vertically. The latter position is the more convenient for visual observations, or when drawings are to be made, but for photographic purposes the former is to be preferred. It is true that many workers have employed the vertical camera successfully, but its range is limited, as it cannot be extended greatly without reaching an inconvenient height, and the strain on the eyes is much more severe when focussing a series of specimens with a vertical than with a horizontal camera. It is also easier to clamp the horizontal form in such a way as to be unaffected by vibration.

The camera may be placed at right angles to the optical bench, the optical axis of the latter exactly entering the opening of the illuminator, or the two may be placed in a parallel position, the beam falling on a plane mirror placed at an angle of 45° with its path, and so being reflected into the illuminator. Which of these dispositions is to be adopted will depend on the shape of the room at the disposal of the operator, and on the convenience of access to the parts. The optical bench, microscope, and camera, may be supported on solid benches attached to the wall, or on metal tables standing in the centre of the floor. Tables for this purpose are supplied by several makers, separate supports being generally used for the optical bench and the camera. Messrs. Zeiss' pattern of camera mounted on such a stand is shown in Fig. 67, and is provided with means of adjustment in a vertical and horizontal direction. The camera is in two sections, of which the one on the right of the figure may be used alone when only a moderate extension is required. With a long camera, means of focussing the microscope from the screen end should be provided, either in the form of a long rod with Hook's joint, or of a rod passing through bearings, having at its end a pulley over which a cord passes by means of which the milled head of the fine adjustment may be turned.

Two glass screens are required for focussing purposes. One of these should be of very fine-grained ground glass, the other of clear glass. In focussing an object, the ground glass screen is first inserted, the iris diaphragm being opened far

enough for the field to be illuminated brightly. The specimen is then moved about on the stage until a suitable field is selected. It is advantageous to have the size of the plate to be used ruled in pencil on the ground glass, so that it may be

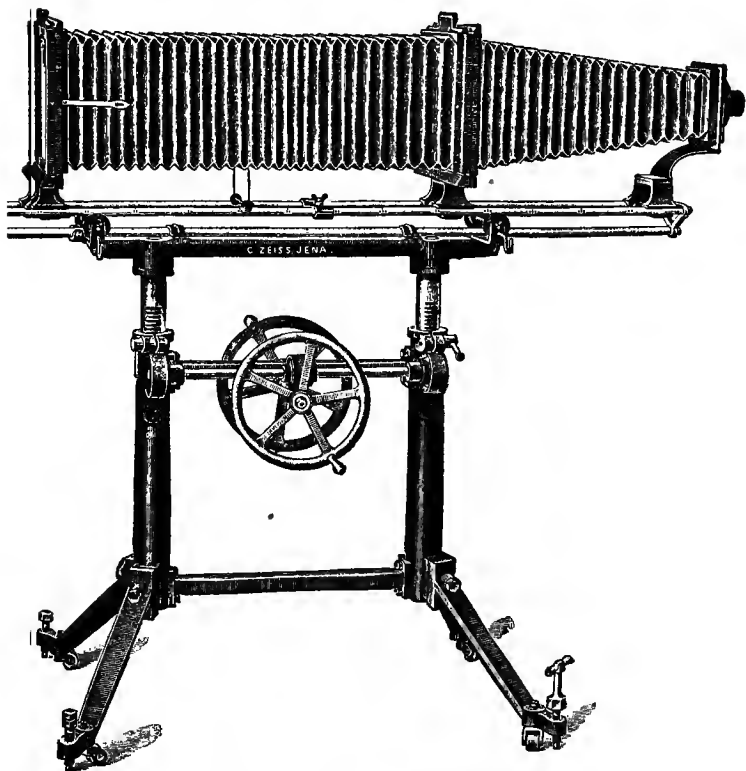

FIG. 67.—Photo-micrographic camera.

seen at once what portion of the field falls within the limits of the plate. The iris diaphragm is then closed until the detail appears clearly up to the edges of the marked area. When the focus appears sharp, the ground glass screen is replaced by the clear glass, and the final focussing performed with the aid of a focussing glass applied to the screen. If a

colour filter is to be used, this should be inserted before the final focussing. The screen is now withdrawn and replaced by the dark slide, and the exposure made in the usual way. It is advisable to reinsert the focussing screen after exposure, in order to see whether the necessary movements have caused any displacement.

Care must be taken to exclude all extraneous light. The connection between the eyepiece of the microscope and the camera should not be made rigidly, but by means of a velvet sleeve with elastic collars or of an adaptor of blackened brass, shown in section in Fig. 68. The optical bench is most conveniently provided with a frame of light iron rods, on which black velvet curtains are hung freely. It is hardly necessary to add that the body-tube of the microscope and the inside of the camera must be thoroughly dead black. The room should have dark blinds, so that all external light may be excluded when high powers

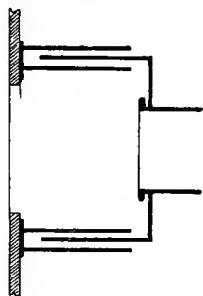

FIG. 68.—Light-tight connection.

are being used, or when the reflecting power of the specimen under examination is low.

It is not proposed to give details of the photographic manipulation, which does not differ from that which is usual in photography for other purposes. In general work, it will be found best to use the plates manufactured for "process" work, which render detail with the necessary clearness. These plates are comparatively slow, but the exposure necessary with an arc lamp is nevertheless to be reckoned in seconds with metals of average reflecting power. In the choice of colour-filters, plates, and developers, the worker should aim at securing sufficient contrast, the tendency of beginners being to produce flat negatives. When accurate colour-filters of known absorption are used, it is advisable to employ plates rendered sensitive to the whole spectrum, such as the Panchromatic plates of Messrs. Wratten and Wainwright.

Prints from negatives may be made on bromide or

platinotype paper or on one of the numerous gaslight papers now manufactured. A half-matt surface is to be preferred to a smooth gloss, although the latter is thought by some to show more detail in prints from weak negatives.

A permanent record of colours, such as those produced on heat-tinting an iron or copper alloy, may be obtained by means of one of the three-colour processes now available. The Sanger-Shepherd process, which involves the preparation of three coloured gelatin positives, and their exact superposition, gives the most brilliant results, but needs much time and patience. A simpler process, involving the use of one plate only, is Lumière's Autochrome, the plates of which are prepared with mixed starch grains, dyed in three different colours. This process has found application in metallography in several quarters.¹ All three-colour methods at present yield only positives, and prints required for reproduction have to be made by some photo-mechanical process. Many persons will prefer to make ordinary prints in black and white, somewhat under-developing, and then to colour the films by hand with the stains used for colouring lantern slides.

Although, in the great majority of instances, the photographic method is at once the most convenient and the most trustworthy means of recording structure, it may sometimes happen that there is an advantage in making a drawing of some particular specimen. This may be called for by the appearance of some structure in a deeply etched alloy, the features of which cannot be simultaneously brought into focus, or by the colorations produced by heat-tinting, which are lost unless some process of colour-photography is employed. Some patience and a little skill are required to make satisfactory drawings, but the task is facilitated by the use of a device, such as the camera lucida or the Abbe reflector, for projecting the microscopic image on to the drawing paper. The drawing of the outline is then reduced to mere tracing. Even without such devices, it is not difficult with a little practice to apply the left eye to the microscope, and to watch the pencil and

¹ P. Goerens, *Metallurgie*, 1908, 5, 19; F. Wüst, *ibid.*, 73; E. F. Law, *J. Iron Steel Inst.*, 1908, i. 151.

paper with the right, the process then becoming one of drawing from a copy. As in all microscopical work, it is important that the worker should accustom himself to using both eyes in turn for observations, the eye not applied to the microscope being kept open. Neglect of this precaution leads to fatigue and strain.

As an appendix to the microscopical methods, an interesting attempt to examine alloys by transmitted radiations, instead of by reflected light, may be mentioned. This consists in exposing a thin section of the alloy to Röntgen rays, the transmitted rays falling on to a photographic plate. When the alloy contains crystals of a metal or compound which is opaque to Röntgen radiations, with a ground-mass consisting mainly of a less dense and more transparent metal, remarkably sharp photographs may be obtained.¹ With the improved technique of modern metallography, however, such a method becomes superfluous, as it naturally fails to reproduce fine detail, and it is mentioned here on account of its intrinsic interest rather than as a practical method of investigation.

¹ C. T. Heycock and F. H. Neville, *Trans. Chem. Soc.*, 1898, 73, 714; *Proc. Camb. Phil. Soc.*, 1898, 9, 417; *Phil. Trans.*, 1900, 194A, 201.

CHAPTER IX

THE CRYSTALLIZATION OF METALS AND ALLOYS

WHILST the crystallization of solid components from molten alloys, and of salts from their solutions, are processes of essentially the same nature, there is one remarkable difference in the course of events in the two cases. Salts commonly separate from their solutions in the form of more or less perfect crystals, bounded by plane faces, and a small crystal continues to grow in all directions in which it is free, retaining the same or a closely similar general form, so that an octahedron remains an octahedron, the development of additional faces being only a subordinate feature. Metals and alloys, on the other hand, only exceptionally form crystals of this kind. As a rule, a small crystalline nucleus grows almost exclusively in the direction of certain axes, giving rise to elongated and much branched forms, the "crystallites" or "crystal skeletons." None of the faces attain any great development, even under favourable conditions of cooling, and curved faces are frequent, the bounding surfaces being sometimes highly curved, to the complete exclusion of plane faces.

Exceptions to these rules occur on both sides. A few inter-metallic compounds, as noticed below, crystallize from molten alloys in well-developed cubic, rhombic, or hexagonal forms, bounded by plane faces, whilst it is possible to cause many salts, and still more readily organic compounds, to assume the skeletal condition, especially by adding viscous or colloidal substances to the solution in which crystallization is taking place.¹ Viscosity, however, cannot be responsible for the peculiar behaviour of metals, which exhibit the tendency to

¹ See O. Lehmann, *Molekularphysik*, vol. i. (Leipzig, 1888), where a vast amount of information respecting the growth of crystals is collected.

form branched skeletons even when deposited electrolytically from solutions of their salts.

The mode of growth of such a skeleton has been studied microscopically in a number of substances by Lehmann. If we suppose crystallization to begin at a centre in the midst of the liquid, a minute crystal is first formed. Crystals can only grow in a supersaturated solution, and as soon as the layer of liquid adjoining the crystal ceases to be supersaturated, growth is interrupted, and can only recommence when the concentration of the layer has been increased by diffusion. Lehmann has shown that the diffusion is greatest at the most sharply pointed angles of the crystal, and it is there that the most rapid growth occurs. Hence, if we suppose the minute nucleus to have the form of an octahedron, its growth takes place in six directions, which in this case coincide with the prolongations of the crystallographic axes. (In the case of a cube, the lines of growth pass outwards through the corners, and do not coincide with the crystallographic axes.) The skeletons thus formed are truly crystalline, and exhibit numerous octahedral faces. Growth soon sets in at some of the solid angles thus produced, with the result that a system of secondary axes, at right angles to the primary axes, is established, and this is succeeded by systems of the tertiary and higher orders, resulting in the filling up of the interstices of the skeleton. With salts growing under ordinary conditions, the "filling-up" process keeps pace with the axial growth, but it fails to do so in metals. Consequently, a metallic crystallite growing freely develops axially, the axes advancing more rapidly than the interaxial matter tending to complete the crystal. Very fine examples of this mode of growth are sometimes seen in the crystals of iron projecting into the internal cavities, or "pipes" of slowly cooled steel ingots.¹ It is also common in native metals, the elongation in the direction of certain axes being very remarkable in the case of filiform gold, and of arborescent silver and copper, all of which are elongated in the direction of the octahedral axes.

If the growth of the crystallite is confined in some

¹ D. Tschernoff, *Rev. Univ. Mines*, 1880, [ii.] 7, i. 129; E. F. Lange, *Mem. Manchester Phil. Soc.*, 1911, 55.

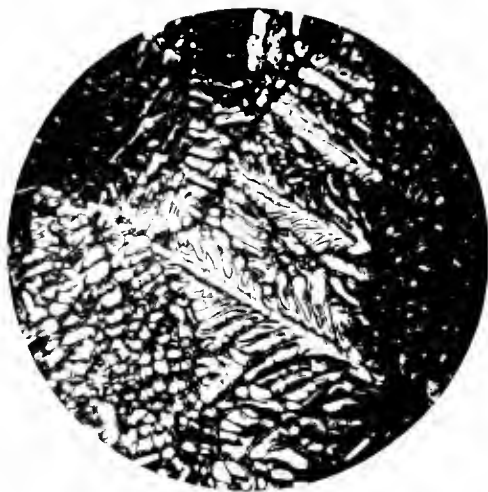

A. Surface of cast tin. $\times 15$.



B. Etched surface of cast tin. $\times 4$.

PLATE I.

[To face page 177.]

directions, only a few of the possible skeletal axes are developed. In an ingot of metal, the outside of which cools most rapidly, the first crystals start from the surface and grow inwards, developing unilaterally. The arrangement of axes is well seen when, as at the free surface of a cast mass, the crystallites are compelled to grow in a plane, the axes perpendicular to that plane being suppressed. The frost-figures produced by the freezing of deposited moisture on window frames are a familiar example of such branched or dendritic growths. Owing to the fact that most metals contract in freezing, the crystallites which form on the surface of a metal or alloy are left in relief by the contraction of the mother-liquor, and this fact makes it possible to photograph the crystallites without developing the structure by etching.

Plate I., A, represents the surface of a thin mass of tin poured on to a smooth block of metal, and a similar appearance is characteristic of most readily fusible metals cast in the same way.

The process of crystallization from any given centre must ultimately reach a limit owing to the interference of adjoining crystallites. The growth of the axes of the crystallite is thus arrested, and the further solidification of metal takes place interaxially, axes of higher order being formed until the spaces are filled with solid matter. If we suppose the original distribution of the centres of crystallization to have been uniform, and growth to have taken place with equal velocity in the direction of each octahedral axis, the solidified mass will be divided up into exactly similar polyhedra. In any actual crystallization, the centres are not uniformly distributed, and the orientation of the axes of neighbouring crystallites is not the same, so that the polyhedra vary in shape and size. They may retain a fairly regular polyhedral form, or may be quite irregular, as is seen in the section of cast tin, Plate I., B, or neighbouring crystallites may grow to an unequal extent, giving rise to interlocked and complicated boundaries, often resembling the sutures of the cranial bones.¹

¹ An entirely different explanation of the formation of crystal grains, based on the assumption of foam-structures in the liquid, has been proposed by G. Quincke, see *Internat. Zeitsch. Metallographic*, 1912, 3, 23.

The typical structure of a solidified metal is therefore that of approximately polygonal "grains," the boundaries of which are not crystal faces, but are due to interference during growth. Each grain is, to use the mineralogical term, an "allotriomorphic" crystal, the outline of which is determined by the presence of neighbouring grains. The form of the grains is somewhat different near to a cooling surface, as the crystallites which start from that surface have time to acquire a considerable longitudinal extension before their growth is interrupted by meeting with other skeletons, crystallization in the interior not setting in until later. The principal growth of the external skeletons is in a direction perpendicular to the cooling surface, and the allotriomorphic crystals which result have

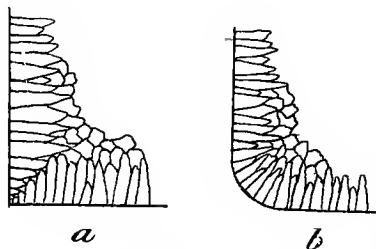

FIG. 69.—Crystal growth in ingots.

consequently an elongated form. This fact is the cause of the weakness of castings having a rectangular outline. The two systems of crystals starting from two adjacent sides meet along a line bisecting the angle, as shown in Fig. 69, *a*. This line is a line of weakness, from the ease with which the crystals lying on opposite sides of it can be separated. The difficulty is avoided by rounding off the angle as at *b*.

Metals deposited electrolytically also form skeletons perpendicular to the surface of the electrode, and lines of weakness are similarly produced at the junction of two systems of crystals starting from the surfaces of a V-shaped groove, making it possible to divide a sheet of electro-deposited metal along such a line with ease.¹

The nature of the allotriomorphic crystals may be studied in a solid metal by polishing and etching.² In such an etched

¹ W. De la Rue, *Mem. Chem. Soc.*, 1845, 2, 300; A. K. Huntington, *Trans. Faraday Soc.*, 1905, 1, 324.

² For a method of studying the arrangement of the crystallites in three dimensions, see C. H. Desch, *Proc. Roy. Phil. Soc. Glasgow*, 1912, 107.

section as Plate I., B, the outlines of the grains are rendered visible by the unequal brightness due to the varying orientation of the original crystallites. If we represent the crystallites which first separate, and the grains formed by them, diagrammatically as in Fig. 70, and remark that etching with a chemical reagent develops the internal structure of a crystal grain by the production of minute facets, we see that these facets will vary in orientation from one grain to another. Light falling on such an etched surface will only be reflected into the tube of the microscope by such facets as have the appropriate orientation, and facets having a different orientation will reflect the light outside the instrument, consequently some grains will appear light and others dark. Such an effect is easily distinguished from a true difference of chemical character between the grains by rotating the specimen on the stage of the microscope. If the difference is one of orientation only, those grains which appear dark in one position appear light under a different incidence of the illuminating beam, and conversely.

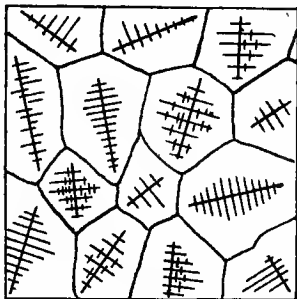

FIG. 70.—Crystallization from centres.

Examination under a higher power proves that the irregularities of surface are due to the exposure of crystalline facets. Crystals of a pure metal, lightly etched, show the formation of minute, regularly shaped "etching-pits," which take the form of negative crystals. The orientation and form of these etching-pits may be employed to determine the crystalline system to which the substance etched belongs.¹ A few typical etch-figures are represented in outline in Figs. 71-73.

¹ See especially, H. Baumhauer, *Resultate der Aetzmethode in der kristallographischen Forschung*, Leipzig, 1894; and for a short explanation of the theory of etch-figures, V. Goldschmidt, *Bull. Univ. Wisconsin*, 1904, 3, 23.

Pure iron (ferrite) gives cubical etching-figures (Fig. 71) which may appear as triangular wedges when the section cuts the crystal grains at certain angles.¹ The pits obtained on a surface of pure lead² are negative cubo-octahedra, and their outlines are therefore either square or hexagonal, according to the orientation of the grain (Fig. 72). The microscopical appearance of such pits is deceptive, they appear on examination to have the form of small crystals projecting *above* the

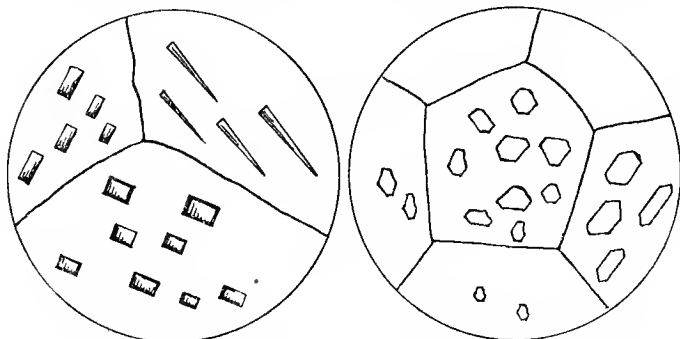

FIG. 71.—Etching-pits in iron.

FIG. 73.—Casting-pits in cadmium.

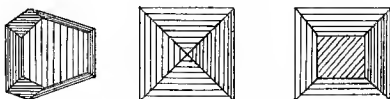

FIG. 72.—Etching pits in lead.

general surface, and it is only by gradually altering the focus of the microscope that their true nature, as depressions *below* the surface, is recognized.

Similar pits, very well defined in outline, are obtained by casting readily fusible metals, especially cadmium, in contact with glass or mica. The small air-bubbles enclosed between the metal and the smooth surface take the form of negative

¹ J. A. Ewing and W. Rosenhain, *Phil. Trans.*, 1899, 193A, 353; E. Heyn, *Zeitsch. Ver. deut. Ing.*, 1900.

² J. C. W. Humfrey, *Phil. Trans.*, 1902, 200A, 225; H. A. Miers, *Min. Mag.*, 1898, 12, 113.

crystals, and are the true equivalent of etching-pits.¹ Such air-bubbles in cadmium are represented in outline in Fig. 73. Like the etching-pits, the orientation of these negative crystals is constant within any one grain, but varies from grain to grain.

With continued etching, the pits cover the whole surface, until a stepped arrangement of minute cubes, rhombohedra, etc., is developed over the whole area. Very perfect cubical structure has been exposed in this way by etching iron containing a little silicon.²

The crystalline form of pure metals may be determined by the observation of crystallites on cooled surfaces³ or by means of etch-figures, when isolated crystals are not available for measurement. The majority of pure metals crystallize in the regular system, namely Cu, Ag, Au, Pb, V, Fe, Ni, Pt, Ir, Os, Pd, Ti, Th, Ge, Hg, Ga, and Cr, as also the non-metals C and Si. Most of the remaining metals crystallize in the hexagonal system, the axial ratios being: ⁴

	<i>a</i> : <i>c</i>
Beryllium	1 : 1'5802
Magnesium	1 : 1'6242
Zinc	1 : 1'3564
Cadmium	1 : 1'3350
Arsenic	1 : 1'4025
Antimony	1 : 1'3236
Bismuth	1 : 1'3035
Tellurium	1 : 1'3298

Tin is tetragonal, having $a : c = 1 : 0.3857$. Several of the metals, however, exist in more than one crystalline modification, in which case the forms stable at high temperatures are of a lower degree of symmetry than those stable at low temperatures, although iron appears to be cubic in the α , β , and γ

¹ Ewing and Rosenhain, *loc cit.*

² J. E. Stead, *J. Iron Steel Inst.*, 1898, i. 145.

³ A large number of good photographs of cast surfaces, compared with etched sections, are given by W. Campbell, *Metallurgie*, 1907, 4, 801, 825.

⁴ W. Barlow and W. J. Pope, *Trans. Chem. Soc.*, 1907, 91, 1150.

modifications.¹ This, however, is exceptional, and in general metals follow the same rule as other crystalline substances, that a polymorphic change with rising temperature results in a diminution of symmetry.

No essential difference in the mode of crystallization of a pure metal is introduced by the presence of a second metal in the liquid alloy, that is, a metal crystallizes from a solvent in the same way as from its own melt. Thus lead separates from a lead-silver alloy containing less than the eutectic proportion of silver in precisely the same way as from molten lead. The process is also the same when the crystals separating are those of a solid solution, except that in this case there is a possibility of a difference of composition between the skeleton first produced and the layers deposited subsequently. Under ideal conditions of cooling, these differences of composition are obviated by the continual readjustment of crystals and mother-liquor, as described on p. 46, and the solid product is then indistinguishable microscopically from a pure metal. Under ordinary conditions of cooling, however, diffusion is unable to keep pace with crystallization, and the crystals deposited consist of layers of progressively varying concentration. Etching with a reagent which attacks one of the component metals more than the other develops a structure in the crystal grains. For instance, an alloy of equal weights of nickel and copper, cooled in a small crucible and etched with hydrochloric acid and ferric chloride, presents the appearance shown in Plate II., A. The etching reagent acts on copper more readily than on nickel. The crystallites separating from the molten alloy are richer in nickel, the metal of higher melting-point, than the outer layers; they are therefore less attacked by the reagent, and appear as light "cores." The boundary between the light and dark areas is not sharp, the proportion of copper varying continuously from centre to periphery. Such a structure is characteristic of all rapidly cooled solid solutions. The development of cores by etching thus gives information as to the mode of growth of crystals, corroborating and

¹ F. Osmond and G. Cartaud, *J. Iron Steel Inst.*, 1906, iii.; *Rev. de Métallurgie*, 1906, 3, 653.



A. Copper 50, nickel 50%. $\times 86$.



B. Brass (Cu 70, Zn 30%) annealed. $\times 86$.

PLATE II.

[To face page 182.]



A. Copper crystallites in an alloy of silver and copper. $\times 200$.



B. Antimony 85, copper 15%. $\times 86$.

PLATE III.

[To face page 183.]

supplementing that derived from the examination of cast surfaces.

Twinned crystals are sometimes observed in cooled metals which have not been subjected to strain, and are then known as "congenital twins"; but they are more often observed in metals and alloys which have been strained and subsequently annealed. Copper, and those alloys of copper which are isomorphous with copper, the so-called α solutions, show this strain-twinning very well. Plate II., B, represents a specimen of brass, the α solid solution of zinc and copper, after being strained and annealed. The arrangement of parallel laminae, with alternating orientation, closely resembles that which characterizes the feldspars in igneous rocks. The β solutions do not undergo twinning when strained and annealed.

EUTECTIFEROUS MIXTURES

In the process of crystallization of a constituent from a eutectiferous alloy, the separation at the cooling surfaces results in the concentration of the more fusible portions in the interior of the mass. It therefore happens in many instances that the whole or greater part of the constituent in excess forms long skeletons growing from the external surface inwards. Such highly-developed crystallites, often branched, are characteristic of many alloys, and are referred to as "arborescent," "dendritic," "pine-tree" or "fern" structures, from their general habit. Typical examples are seen in Plate III., A and B.

In the first of these, representing an alloy of silver and copper, the crystallites consist of copper retaining a small quantity of silver in solution. They take the form of long primary axes, with well-developed secondary, but only a faint indication of tertiary, axes. The apparent breaking-up of the principal axes into isolated masses is due to the surface of the section cutting the crystallites obliquely, so that the principal axes lie partly above and partly below the plane of the section. The isolated masses are really sections through secondary axes perpendicular to that plane. In Plate III., B, which represents an alloy of antimony and copper, the

crystallites are of pure antimony, and are composed of primary, secondary, and comparatively small tertiary axes.

The two groups of crystallites just considered differ conspicuously in one respect. Whilst the antimony skeletons are terminated by distinct angles, and may be imagined as built up of the familiar crystals of antimony, the outlines of the copper skeletons are smoothly rounded, and there is no indication of any crystal faces. Both conditions are of common occurrence in alloys. Whilst antimony and bismuth are typical of metals which form sharply angular crystals and crystallites, copper, magnesium, and lead present themselves only in rounded forms. It would appear that the surface tension at the boundary where solidification is taking place is sufficient in the latter case, and insufficient in the former, to hold in check the tendency of the metallic particles to assume a definite crystalline arrangement. We are almost entirely without information as to the conditions of tension prevailing at the surface of crystallizing metals.

A further example of a similar structure is illustrated in Plate XIV., A, Chapter XVII.

THE EUTECTIC

A eutectic alloy consists, as has been shown, of an intimate mechanical mixture of two solid phases, produced by solidification at a constant temperature. The pattern produced by the intergrowth of the two phases takes a great variety of forms, and the beauty of many microscopic structures is owing to such patterns. The simple intermixture of small crystals of the two constituents, generally observed in mixtures of organic substances, and occasionally in igneous rocks, is rare amongst alloys. Metallic eutectics commonly show a definite orientation of one constituent, or else the two constituents are interlaminated in curved forms, in which it is difficult to recognize crystalline structure.

A pure eutectic alloy, solidifying without undercooling, passes from the liquid to the solid state at constant temperature. The laminated structure observed suggests that the solidification of the two phases is not strictly simultaneous, but that

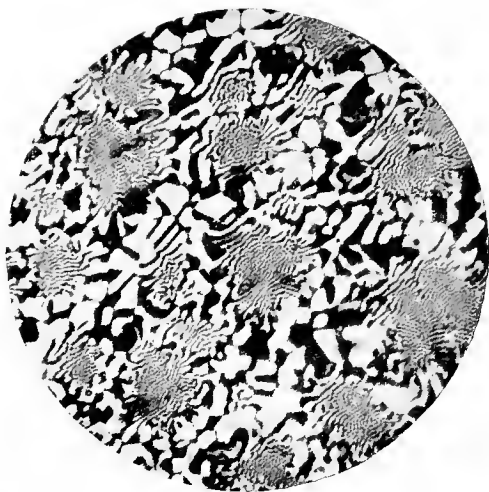

A. Eutectic of copper and copper phosphide. $\times 200$.



B. Eutectic of copper and copper phosphide. $\times 200$.

PLATE IV.

[To face page 185.]

particles of the first and second phases crystallize alternately.¹ This process begins, like the crystallization of a pure metal, at a number of centres, and the interference of the systems leads to the formation of polyhedral masses or "colonies,"² resembling in general form the crystal grains of pure metals and solid solutions, but composed in this instance of an intergrowth of two phases. On etching, as the laminæ in neighbouring grains have generally a different orientation, the boundaries are developed, and under a low magnification the appearance is not unlike that of homogeneous crystal grains. Under oblique illumination, many eutectic alloys when etched present an iridescent lustre like that of mother-of-pearl, owing to the scattering of the incident light by the laminæ. This pearly appearance, first observed by Sorby in the eutectoid of iron and iron carbide, hence called by him "the pearly constituent," and by Howe "pearlite," is characteristic of eutectic and eutectoid alloys. The arrangement of the laminæ which produce it takes many forms, classified by Stead³ as the curviplanar, the honeycombed or cellular, and the rectiplanar. Without adhering strictly to this nomenclature, we may arrange the types of eutectic most frequently observed in approximately the order adopted by Stead.

1. The two solid phases form parallel curved bands, in which no trace of crystalline outline is to be observed. Pearlite is a good example of this type (Plate XI., B). The narrow bands of cementite, Fe_3C , and the broader bands of ferrite, Fe , exhibit parallel arrangement and may have a considerable curvature. Another variety of this type is seen in the eutectic of copper and copper phosphide (Plate IV., A and B). The parallel bands are involved in complicated patterns. In A the bands become broader and more irregular as the border of the grain is approached; in B a grouping of the structural elements about a central rod, also consisting of parallel bands, is observed; but in neither case is there any clear indication of crystalline form.

¹ Recent experiments, however, indicate that the two constituents separate simultaneously, and that the structure depends on the relative velocities of crystallization. R. Vogel, *Zeitsch. anorg. Chem.*, 1912, 76, 425.

² C. Benedicks, *Internat. Zeitsch. Metallographie*, 1911, 1, 184.

³ *Proc. Cleveland Inst. Eng.*, 1900, Feb.; *Metallographist*, 1902, 5.

2. The bands have a toothed or indented form, the more or less regular undulations being repeated in neighbouring laminæ. This arrangement is seen in the eutectic of lead and tin.

3. The toothed bands of Group 2 are sometimes observed, under higher magnification, to be composed of very numerous rods parallel to one another and normal to the direction of the laminæ. This is seen in the eutectic of copper and silver (Plate III., A). The short rods of copper have the same orientation over considerable areas, and when cut transversely appear as dots; whilst an oblique section, such as that on the right-hand side of the figure, appears as if crossed by parallel lines. The eutectic of copper and copper oxide has the same structure, and a third example is the eutectic of nickel and nickel phosphide. In all these alloys we must regard the rods as crystallites having parallel orientation.

4. The third class passes through gradations into the honeycombed structure, well represented by the cementite-martensite eutectic of white cast-iron (Plate XIV., B). Whilst the general parallelism and similar orientation throughout certain areas is obvious, the crystalline nature of the grouping is less easily observed than in the preceding group.

5. Boxed forms, characterized by the formation of simple polyhedral crystallites divided transversely by numerous parallel septa, are most typically developed in the alloys of bismuth. Plate V., A, represents an alloy of bismuth and tin, and an angle of such a crystallite is seen extending to the centre of the field. Indications of the same structure in an incomplete form appear in the lower half of Plate V., B, representing an alloy of bismuth and lead.

6. Occasionally the eutectic is composed of plane plates of one constituent disposed in a radiating manner, the second constituent occupying the interstices. The eutectic alloys of silver and lead and of lead and antimony yield thin flat plates on deep etching. Such a radial arrangement of plates resembles very closely the spherulitic structures observed in many igneous rocks, especially those formed by the slow devitrification of an originally glassy magma. A comparison of spherulites and

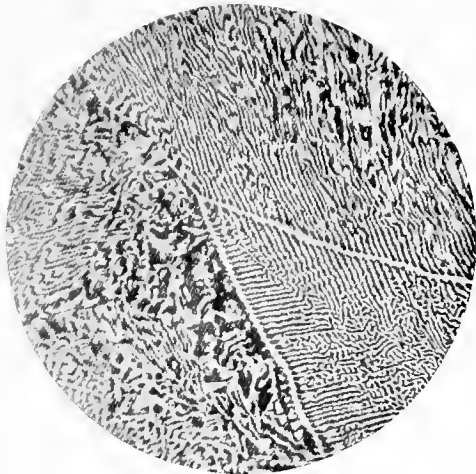

A. Eutectic alloy of bismuth and tin. $\times 200$.

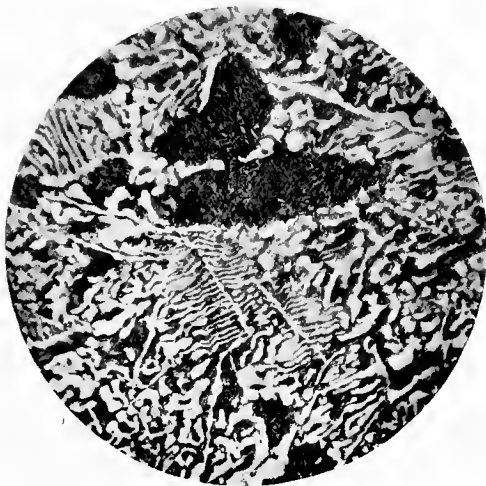

B. Eutectic alloy of bismuth and lead. $\times 200$.

PLATE V.

[To face page 186.]



A. Alloy of antimony and Cu_2Sb . $\times 200$.



B. Eutectic alloy of antimony and Cu_2Sb . $\times 200$.

PLATE VI.

[To face page 187.]

eutectic alloys suggests a great similarity in the process of crystalline intergrowth in the two cases.¹

7. The eutectic alloy of antimony and copper antimonide occasionally presents a structure which throws much light on the process of crystallization of eutectics.² In alloys containing an excess of antimony above the eutectic proportion, the antimony particles, instead of forming continuous bands, may appear as minute crystals of similar orientation (Plate VI., A). The orientation is obviously determined by that of the original crystal skeleton of antimony near to which they are grouped. The entire similarity of the principal and the subsidiary crystallites proves that the antimony alone determines the orientation, the copper antimonide (dark in the photo-micrograph) merely acting as a filling material. At a greater distance from the principal skeletons, the structural arrangement (Plate VI., B) is less easily deciphered, but the long, tapering laminæ may be recognized as being also crystallites of antimony, cut at a very oblique angle. A transition to curved forms is noticeable here and there, and some specimens of this eutectic, free from excess of either constituent, have in fact the typical curved banded structure of Group 1, without any indication of crystalline form.³

A comparison of Groups 3 and 7 suggests that the pattern of the eutectic is determined principally, if not exclusively, by the crystalline habit of one of the constituents, the other behaving to some extent as a plastic substance, yielding and adapting itself to its growth. This conclusion has been arrived at by several investigators. It remains as yet undetermined to which physical property this action of one of the constituents is due. It has been suggested by Stead that the harder constituent has a determining influence on the crystalline habit; by Rosenhain, that it is the constituent present in the larger

¹ J. H. Teall, *Quart. J. Geol. Soc.*, 1901, 57, lxii. For the characteristics of spherulitic crystallization in rocks, see W. Cross, *Proc. Phil. Soc. Washington*, 1891, 11, 411; J. P. Iddings, *ibid.*, 445.

² Communication by the author to Section II^b of the International Congress of Applied Chemistry, 1909.

³ J. E. Stead, *J. Soc. Chem. Ind.*, 1898, 17, 1111; A. Baikoff, *Bull. Soc. d'Encouragement*, 1903, 102, 626.

proportion by volume in the eutectic alloy ; and by the author, that the power of orientation, as shown by the ability to form extended crystal skeletons, is the determining factor.

As the composition of the alloy departs in the one direction or the other from the eutectic proportion, the structure naturally changes. A small deviation may fail to bring about the appearance of the constituent in excess in the form of distinct crystals or crystallites, but is often rendered visible by a coarsening of the eutectic structure, first apparent at the margin of the grains. Such a thickening of the structural elements of the eutectic, due to a minute excess of copper phosphide over the eutectic proportion, is seen in Plate IV., A.

If the departure from the eutectic composition be any greater, crystallites of the constituent in excess make their appearance, at first as small isolated masses, becoming united to form skeletons or larger crystals with further change in the composition. A comparison of Plates III., B ; VI., B ; and VII., A, will illustrate the variations of structure as the eutectic point is passed. In Plate III., B, the antimony is in excess, and its long crystal skeletons are separated by the eutectic of antimony and copper antimonide. Plate VI., B, represents the pure eutectic alloy, whilst in Plate VII., A the long dark crystals are those of the compound Cu_3Sb , now the constituent in excess.

INTER-METALLIC COMPOUNDS

An alloy consisting entirely of an inter-metallic compound crystallizes in the same manner as a pure metal. The typical structure of such an alloy is consequently that of a uniform substance, divided into polyhedra presenting themselves as fine polygonal boundaries in an etched section. Similarly, the structure of a solid solution composed of an inter-metallic compound and one of its components does not differ from that of the solid solutions previously described. When, however, the compound is accompanied by a eutectic, its development often differs in a marked degree from that of a single metal. The tendency to form crystals with plane faces, like the crystals of salts deposited by an aqueous solution, instead of skeletons, is

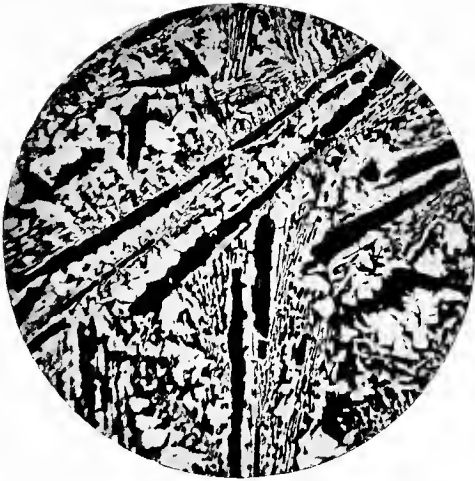

A. Antimony 75, copper 25%. $\times 86$.

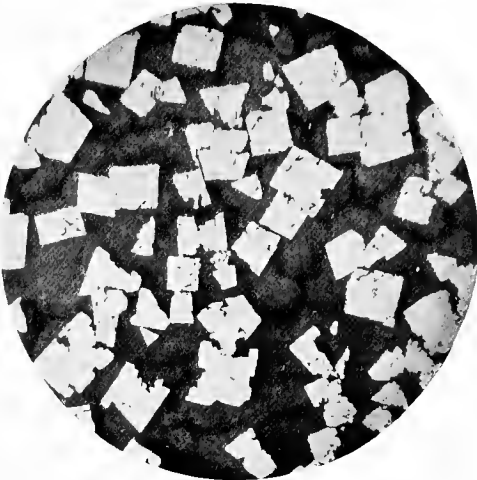

B. Alloy of tin and antimony. $\times 20$.

PLATE VII.

much more pronounced among inter-metallic compounds than among the metals. The crystallographic constants of a few only of such compounds have been observed, but a rhombic habit certainly predominates. In general, it may be said that the symmetry of the compound is lower than that of its components. Cubic forms are rare, and such apparent cubes as are observed are probably less simple crystals, having a pseudo-cubic habit. An instance of this is seen in Plate VII., B, the cubic or pseudo-cubic crystals of which consist of a solid solution approximating to the composition SnSb. A rhombic outline is much more commonly observed in etched sections, among the compounds exhibiting this habit very distinctly being

AgMg_3 , Al_6Co , Al_2Cu (Plate VIII., A), Sb_2Zn_3 , and AuMg_3

The constants of a few compounds have been determined, amongst them being

Cd_3Sb_2 , rhombic, $a : b : c = 0.7591 : 1 : 0.9687$;

FeSb_2 , rhombic, $a : b : c = 0.5490 : 1 : 1.1224$;¹

NiSb , hexagonal, $a : c = 1 : 1.2940$;

SbZn , rhombic, $a : b : c = 0.7609 : 1 : 0.9598$;

Al_2Fe , monoclinic, $a : b : c = 1.5413 : 1 : 1.9158$, $\beta 107^\circ 41'$;²

Cd_2Na and Mg_2Sn are described as regular, the former forming combinations of the octahedron and regular dodecahedron, and the latter octahedra.³

When a compound of the above type is present in large quantity, the small crystals may unite to form skeletons. This is the case, for instance, with FeSb_2 , which crystallizes in simple rhombs if present in small excess over the eutectic composition, but in larger excess forms characteristic skeletons.

CRYSTALLIZATION FROM SOLID SOLUTION

An alloy composed of two solid solutions frequently resembles, especially under low magnifications, one consisting

¹ N. S. Kurnakoff and N. Konstantinoff, *Zeitsch. anorg. Chem.*, 1908, 58, 1.

² P. Groth, *Chemische Krystallographie*, Teil I., Leipzig, 1906.

³ P. von Suschtschinsky, *Zeitsch. Kryst. Min.*, 1904, 38, 264.

of crystals of one constituent, surrounded by a eutectic. Higher magnification, however, fails to develop a eutectic structure in the ground-mass, which remains homogeneous on etching, or at most exhibits the zonal variation of composition characteristic of solid solutions in a state of imperfect equilibrium. The tin-antimony solid solution in Plate VII., B, is a ground-mass of this kind; the etching has developed the crystal boundaries, which appear as irregular lines, but there is no indication of any eutectic structure.

If the alloy solidifies in the first instance to form a single solid solution, from which a new constituent crystallizes on further cooling, the first appearance of the new crystals takes place, in the majority of cases, at the bounding surfaces of the original polyhedra. An alloy of 62 per cent. Cu and 38 per cent. Zn, for example, solidifies as a single solid solution, β (p. 62), and at about 700° crystals of α separate, the solubility curve of α in β being crossed at that point. The first separation of α takes place at the boundaries, and the crystals there formed grow inwards towards the centre of the polygonal grains. Plate VIII., B, representing an aluminium bronze, is a typical example of the structure of such an alloy, an $\alpha\beta$ aluminium-copper alloy being, in fact, indistinguishable from an $\alpha\beta$ zinc-copper alloy in which the structural elements are present in the same proportions. Plate IX., A, represents an $\alpha\beta$ copper-zinc alloy, in which the boundaries are curved. The section is cut transversely through a rolled bar. Further examples of structures produced in the breaking-up of solid solutions occur amongst the alloys of iron and carbon, and will be noticed in Chapter XVII.

CRYSTALLIZATION IN TERNARY SYSTEMS

The process of crystallization of a ternary alloy is precisely the same, in its initial stages, as in a binary system. Both binary and ternary eutectics may occur as micrographic constituents, the former generally presenting itself as a border surrounding the primary crystals, whilst a ternary eutectic occupies the intercrystalline spaces. A simple case is illustrated in



A. Copper 55, aluminium 45%. $\times 86$.



B. Aluminium bronze. $\times 200$.

PLATE VIII.

[To face page 190.]

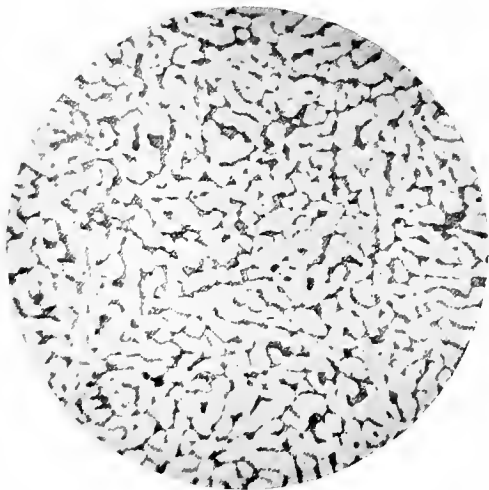

A. Copper 60, zinc 40%. Transverse section of rolled bar. $\times 86$.

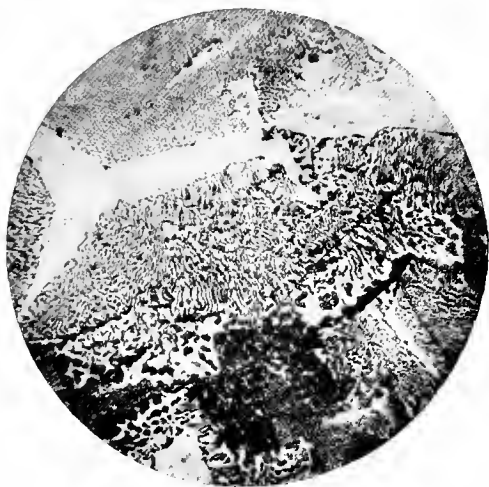

B. Alloy of bismuth, lead, and tin. $\times 200$.

PLATE IX.

[To face page 191.]

Plate IX., B, which represents an alloy of bismuth, tin, and lead, the bismuth being in excess. The primary crystals of bismuth, of which two appear in the upper part of the photograph, are surrounded by the characteristically banded eutectic of bismuth and tin. The orientation of this honeycombed structure is determined by that of the primary crystals. The ternary eutectic, the structure of which is not very clearly resolved, appears as a dark, almost black, mass, in the lower part of the photograph. If more completely resolved, it would be found to consist of the three metals in a finely inter-laminated condition.

An interesting case, which presents itself in technical practice, is the disturbance of the equilibrium of two solid solutions produced by the introduction of a third metal. An important class of alloys of copper and zinc consists of conglomerates of two solid solutions, α and β . The addition of small quantities of tin, silicon, manganese and other elements to such alloys is a common practice, and the study of the alterations of structure involved has given interesting results.¹ The third metal dissolves, up to a certain limit of concentration, in the two solid solutions, any excess above this limit separating, in combination with some of the copper, as a third constituent. The eutectic relations in the system are as yet unknown. As long as the proportion of the third metal is below the limit of saturation, its effect is to displace the limits of the two solid solutions, in other words, the added metal replaces a certain quantity of zinc, usually much exceeding its own weight. For example, tin replaces twice its weight of zinc, and an unsaturated ternary alloy of copper, zinc, and tin, is indistinguishable microscopically from a binary alloy containing a higher percentage of zinc. The physical and mechanical properties of the ternary alloy closely approach those of the binary alloy which it resembles in structure. We may therefore speak of a "fictitious" value for the zinc content, bearing a definite relation to the quantity of added metal. The value may be calculated in the following manner:—

Each of the elements considered has a definite coefficient

¹ L. Guillet, *Rev. de Métallurgie*, 1906, 3, 243.

of equivalence t , 1 per cent. of it replacing t per cent. of zinc, the quantities being recalculated to 100 per cent. These coefficients are determined by experiment, the values determined by Guillet being :

Al 6	Pb 1
Sn 2	Fe 0.9
Mg 2	Mn 0.5
Si 10	

Antimony, cadmium, and phosphorus are dissolved to so small an extent as to be incapable of displacing an appreciable quantity of zinc.

An alloy containing 68.47 per cent. Cu, 27.03 per cent. Zn, and 4.50 per cent. Al, has the same structure and nearly the same properties as one containing 56 per cent. Cu and 44 per cent. Zn :

$$\text{"fictitious" Zn} = \frac{(27.03 + 4.50 \times 6) 100}{68.47 + 27.03 + 4.50 \times 6} = 44$$

In general, if B is the actual and B' the "fictitious" percentage of zinc, and q the quantity of the added metal,

$$B' = \frac{(B + tq) 100}{100 + tq}$$

If we know the values of B and q , and determine B' by a microscopical examination, and if necessary by a planimetric analysis of the alloy, t , the coefficient of equivalence, is given by the formula—

$$t = \frac{100 (B' - B)}{q (100 - B')}$$

And in a similar manner, B' or q may be calculated if the other quantities are known.

Taking aluminium, with its high coefficient of 6, as an example, its action in modifying the structure of the copper-zinc alloys is as follows. An alloy is converted by the addition of aluminium into one having the properties and structure of an alloy of higher zinc content, in accordance with the formulæ given above. An alloy consisting of the α constituent

only may thus be converted into an $\alpha + \beta$ alloy, an $\alpha + \beta$ into a β , or β into a $\beta + \gamma$ alloy. A separate aluminium constituent does not appear until 10 per cent. Al has been added.

Manganese is dissolved up to 8 per cent. ; the solubility of the other elements enumerated is less. When more than one element is introduced into a copper-zinc alloy, the constitution of the product may be calculated by the above formulæ, only replacing tq by Σtq , provided that the quantities are insufficient to cause the separation of new constituents.

NON-METALLIC ELEMENTS IN ALLOYS

The relations of the non-metals to each other and to the metals fall for the most part outside the scope of this work, but a few non-metals are capable of entering into associations which may be classed as true alloys. For example, steel and cast-iron are to be considered as alloys, although carbon is a non-metal. Its solutions in iron, however, have an entirely metallic character, as has the carbide, Fe_3C , which crystallizes in hard, glistening plates. Manganese carbide is also metallic, but the easily decomposable carbides of aluminium, calcium, etc., have no metallic properties, and do not form alloys. Silicon is another alloy-forming element, and in fact may be considered for metallographic purposes as a metal, from the general resemblance of its behaviour in association with metals to that of a highly infusible metal. Even phosphorus unites with iron, copper, and tin, to form metallic phosphides. The structures represented in Plate IV. are characteristic of metals, and the compound Cu_3P , which is one of the constituents of the alloy, has all the properties of a hard, brittle inter-metallic compound.

Mixtures of this class do not retain the metallic character throughout the whole range of composition. When the proportion of the non-metallic component exceeds a certain limit, the mixtures have no longer the properties of alloys. It is often impossible to prepare the complete series, owing to the insolubility of the non-metal when a certain limit is

exceeded (thus carbon cannot be dissolved in iron at any accessible temperature to a higher concentration than 7 per cent.) or to the high dissociation pressure of the combinations formed, causing the escape of the volatile component when the mixture is heated under atmospheric pressure. Thus the systems formed by iron, nickel, manganese, and copper with phosphorus, have only been examined over a range of composition in which the phosphorus is less than about 15 per cent., this being the maximum quantity retained at the melting-point under atmospheric pressure.

Oxygen less often needs consideration as an alloy-forming element. Copper eagerly absorbs oxygen when fused, the cuprous oxide produced dissolving in the metal to form a homogeneous solution. The freezing-point diagram is reproduced later (Fig. 76). Nickel behaves in an exactly similar manner.¹ Other oxidizable metals absorb oxygen, but the oxide formed is insoluble, and merely forms a dross on the surface. The behaviour of silver is unusual. Molten silver dissolves considerable quantities of oxygen, but rejects it at the moment of freezing, the escape of the dissolved gas giving rise to the well-known phenomenon of "spitting" observed when silver ingots are cooled. The behaviour of the gases dissolved in metals is of great interest. The effect of hydrogen on iron has been studied to a limited extent,² whilst that of nitrogen on the same metal has been the object of numerous studies, on account of a supposed embrittling effect of nitrogen, even in small quantities, on steel.³ Very interesting results have been obtained by Sieverts,⁴ who finds that the solubility of gases in metals generally increases with the temperature, with a sudden increase on passing from the solid to the liquid state. The solubility is proportional to the square root

¹ R. Ruer and K. Kaneko, *Metallurgie*, 1912, 9, 419.

² W. C. Roberts-Austen, 5th Report to Alloys Research Committee, 1899, 42; E. Heyn, *Stahl u. Eisen*, 1900, 20, 837.

³ H. Braune, *Rev. de Métallurgie*, 1905, 2, 497; H. Le Chatelier, *ibid.*, 503, 898; H. Tholander, *Fernkontorets Ann.*, 1888, 425; C. E. Stromeyer, *J. Iron Steel Inst.*, 1909, i, 404.

⁴ A. Sieverts and W. Krumbhaar, *Ber.*, 1910, 43, 893; *Zeitsch. physikal. Chem.*, 1910, 74, 277; A. Sieverts, *ibid.*, 1911, 77, 591.

of the pressure. Hydrogen is dissolved in this way by copper, nickel and iron, but is insoluble in cadmium, thallium, zinc, lead, bismuth, tin, antimony, silver and gold. Its solubility in copper is unchanged by alloying with silver, increased by alloying with nickel or platinum, and diminished by alloying with gold, aluminium or tin, the effect being proportional to the quantity of the added metal as long as no change in constitution takes place. Sulphur dioxide is insoluble in solid, but very soluble in molten copper. On freezing, a large part of the dissolved gas is retained mechanically.

MECHANICAL ENCLOSURES

The microscopical examination of alloys frequently reveals enclosures of substances which have been mechanically entangled by the fused alloy, and have not formed a part of the homogeneous system. Some practice is required to distinguish these accidental constituents from phases sharing in the equilibrium. Chief among them are the masses of slag enclosed in cast ingots. Steel commonly contains minute masses of silicate slag, in which a crystalline structure may be developed, and of manganese sulphide, the latter forming globules of a characteristic dove-grey colour. The form of the globules is dependent on the treatment to which the metal has been subjected, rolled masses exhibiting an elongation of all enclosures in the direction of rolling. The examination of micro-sections for slag masses is of considerable importance in technical practice, on account of their influence on mechanical properties. Ferrous sulphide, for example, forms films separating the crystal grains, and is consequently a source of weakness when the steel is worked. The addition of manganese converts the sulphur into manganese sulphide, which collects in round or oval globules, which, as they do not interrupt the continuity of the metallic crystals, have less influence on the strength.¹

¹ The constitution of the sulphide enclosures in steel is described by G. Röhl, *Iron Steel Inst. Carnegie Schol. Mem.*, 1912, 4, 28.

The slag in wrought iron occurs in narrow, thread-like masses lying in the direction of rolling or working, so that in a longitudinal section they appear as narrow lines, or in a transverse section as round dots.

Crystalline enclosures are of less frequent occurrence. Well-defined crystals of stannic oxide are met with in bronzes which have absorbed oxygen during melting,¹ as they do not separate readily from the molten metal. Minute crystals of corundum may also be observed in metals and alloys prepared by the aluminothermic method. Crystal skeletons of manganese sulphide have been observed in large steel ingots, and have the appearance of having solidified before the mass of the metal.² This points to a considerable solubility of the sulphide in steel above the melting-point.

¹ E. Heyn and O. Bauer, *Zeitsch. anorg. Chem.*, 1905, 45, 52.

² A. A. Baikoff, *Ann. Inst. Polyt. St. Petersburg*, 1907, 8, 289. See S. Wologdine, *Rev. de Métallurgie*, 1908, 5, 177.

CHAPTER X

UNDERCOOLING AND THE METASTABLE STATE

HITHERTO only systems in a state of stable equilibrium have been considered, the assumption being made that each new phase makes its appearance at the temperature at which it is theoretically formed. This condition is by no means always fulfilled in practice. The molecular inertia often causes a body to remain in a condition differing from that of maximum stability, until some external circumstance causes rearrangement to take place. The simplest instance of this is seen in the formation of the solid phase in a cooling homogeneous liquid. When pure water is cooled below its freezing-point in a clean vessel, the separation of ice does not take place when the temperature reaches 0° . On further cooling, a point is reached at which crystallization suddenly sets in, and the temperature rises rapidly to 0° , freezing then proceeding steadily. This fact was observed by Fahrenheit in the eighteenth century. Fused metals exhibit the same behaviour, and the phenomenon is now known to be a general one, the terms *undercooling* or *superfusion* being applied to it.¹

The effect is shown in the cooling curve, which assumes the form shown in Fig. 74, the normal curve, in the absence of undercooling, being indicated by the dotted straight line. When the undercooling is considerable, and the mass is losing heat rapidly to its environment, the latent heat liberated may be

¹ The term "undercooling" (Germ. *Unterkühlung*) will be employed in what follows, since, as will be shown, the phenomenon occurs at other changes of state besides that of freezing, to which alone the term "superfusion" (Fr. *surfusion*) is applicable.

insufficient to raise the temperature to the true freezing-point A, and the summit of the curve will therefore indicate too low a freezing-point. For this reason, undercooling is to be avoided in the taking of cooling curves.

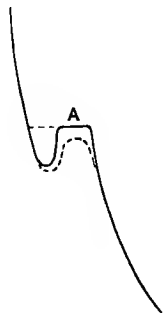

FIG. 74.—Effect of undercooling on cooling curve.

In the operation of cupelling gold, the globule of molten gold under certain conditions emits a brilliant light at the moment of solidification. The development of heat at this point was at first¹ attributed to a chemical reaction between dissolved oxygen and metals present as impurities. A careful study of this “flashing” or “éclair,” proved, however, that the phenomenon is due to undercooling.² The gold must be in a clean state to show the effect, and must not be shaken during

cooling. Its temperature falls below the freezing-point until crystallization sets in, and the development of heat causes the glow. If the globule is touched with a gold wire when it has cooled to the freezing-point, freezing takes place normally without any flashing.

Soon after the first observation of undercooling by Fahrenheit, it was observed³ that saturated salt solutions behave in a similar manner, it being possible to cool them below the point at which crystallization should take place, the separation of crystals setting in suddenly when further cooled, the temperature at the same time rising to the crystallizing point. What has been said of pure substances therefore also applies to the separation of one component from a mixture. Solutions cooled in this way below their proper crystallizing

¹ A. Levol, *Ann. Chim. Phys.*, 1845, [iii.] 15, 55.

² A. D. van Riemsdyk, *ibid.*, 1880, [v.] 20, 66; *Chem. News*, 1880, 41, 126, 266.

³ J. T. Lowitz, *Crell's chem. Ann.*, 1795, 1, 3. A full history of the subject of undercooling and supersaturation is given by W. Ostwald, *Lehrb.* II. 2, i. 704 ff. Accurate measurements of the extent of undercooling in various metals and alloys were made by W. C. Roberts-Austen, *Proc. Roy. Soc.*, 1898, 63, 447.

points are said to be supersaturated, and the sudden crystallization of a supersaturated solution of sodium sulphate in water is a common lecture experiment.

If the viscosity of the liquid is high, the undercooling may be carried very far. Many organic substances—for instance, papaverine—become very viscous in the undercooled state, and on reaching the ordinary temperature consist of a glassy mass, which may be preserved indefinitely without crystallization taking place. Ordinary glasses are mixtures, chiefly of silicates, the viscosity of which in the undercooled state is so great that crystallization entirely fails to occur during cooling in the ordinary process of manufacture. If subsequently treated in such a way as to facilitate crystallization, as by prolonged heating at a temperature sufficient to lessen the viscosity to a marked degree, “devitrification” takes place, crystals corresponding with the stable solid phases making their appearance. Glassy volcanic rocks, such as obsidian, are also formed from an undercooled magma, and all stages of their devitrification are found in nature.

The formation of glasses, that is, of rigid non-crystalline masses, by undercooling, has not been observed in metals or alloys, the viscosity of which is in fact low.¹ In the cooling of an alloy, the formation of a solid phase always takes place, although the temperature may be considerably below that corresponding with the true freezing-point.

Investigations of undercooled liquids have shown that the region below the solubility curve should be divided into two parts. In the first, immediately below the curve representing the equilibrium of the solid and liquid phases, crystallization does not take place spontaneously, but only when a crystal of the solid substance (or of a solid isomorphous with it) is introduced. At a lower temperature, crystallization begins

¹ Very few determinations of the viscosity of molten metals exist. Koch, *Ann. Physik*, 1881, **14**, 1, made a series of measurements with mercury, and C. E. Fawsitt, *Trans. Chem. Soc.*, 1908, **93**, 1299, obtained figures for mercury, tin, lead, and bismuth, varying from one to three times the viscosity of water. It is a familiar fact that metals, even of high melting-point, form mobile liquids, which may be poured like water if free from dross.

spontaneously, shaking or other mechanical disturbance being sufficient to initiate it. On the suggestion of Ostwald, these regions have been termed *metastable* and *labile* respectively. It was long a matter of doubt whether there was any true boundary between the metastable and labile regions, it having been argued that the apparent existence of a region in which crystallization would not occur spontaneously was only due to the small number of crystal centres, corresponding with a small undercooling.¹ This has been disproved by the exhaustive investigations of Miers and his collaborators.² It has now been shown that spontaneous crystallization, that is, the appearance of the solid phase without the previous introduction of a particle of the solid ("inoculation") does not take place above a certain definite temperature, which is characteristic of each substance. The same holds good of mixtures. Below the solubility curve, and approximately parallel with it, lies a curve representing the temperature at which each solution begins to deposit crystals spontaneously, without inoculation with a crystal. To this curve the name of *supersolubility curve* has been given.

Most supersolubility measurements have been made with aqueous solutions of salts. Metallic alloys have not yet been investigated from this point of view, but the mixtures of two organic substances, betol and salol, have been fully investigated,³ and it is practically certain that the diagram constructed from the data thus obtained is typical of the conditions which must prevail in alloys. The diagram is therefore reproduced (Fig. 75). It will be seen that the two compounds form a simple eutectiferous series, no solid solutions being formed. The freezing-point curve therefore consists of two branches, AC and BC, intersecting at the eutectic point C. The two supersolubility curves, DF and EF, also intersect at a point, F, to which the name *hypertectic point* has been given. It will be

¹ G. Tammann, *Zeitsch. physikal. Chem.*, 1898, 25, 442.

² H. A. Miers and F. Isaac, *Trans. Chem. Soc.*, 1906, 89, 413; H. Hartley and N. G. Thomas, *ibid.*, 1906, 89, 1013; H. Hartley, B. M. Jones, and G. A. Hutchinson, *ibid.*, 1908, 93, 825.

³ H. A. Miers and F. Isaac, *Proc. Roy. Soc.*, 1907, 79A, 322; F. Isaac, *ibid.*, 1910, 84A, 344.

noticed that the abscissæ of these two points are not necessarily the same, so that the eutectic and hypereutectic mixtures need not have the same composition.

The area ACBEFD is the metastable region. Mixtures represented by points falling within its limits are liquid, and

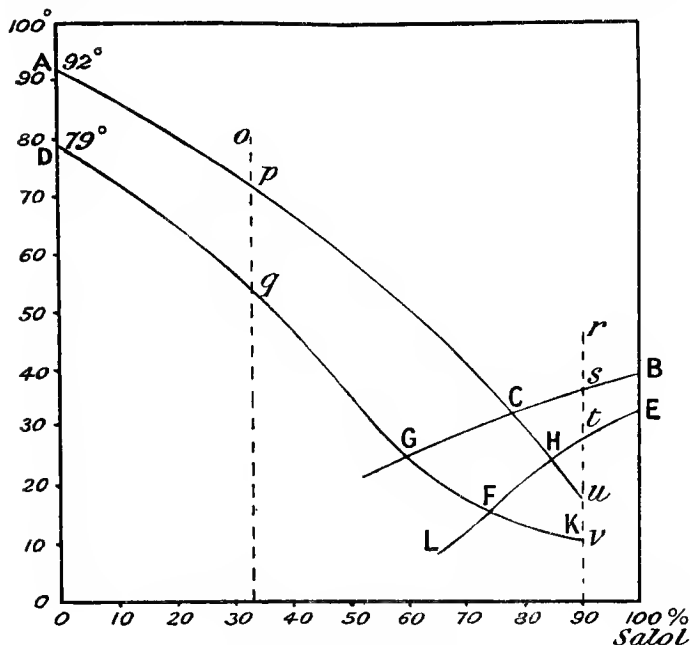

FIG. 75.—Betol and salol.

only deposit crystals if the appropriate solid phase is introduced. Below the line DFE is the labile region, in which crystallization can occur spontaneously, although it may sometimes fail to occur when either of the supersolubility curves is crossed. The significance of the four curves may now be illustrated by the consideration of a few possibilities.

A mixture represented by the point *o* is cooled, the access of solid matter being prevented. When the point *p* is reached, the solid phase being absent, crystallization does not take place,

and the mixture remains liquid until the temperature has fallen to q . The supersolubility curve of betol, or more generally, of the substance M, has now been cut, and crystallization takes place spontaneously if the mixture is shaken. The composition of the part remaining liquid is now represented by a point travelling down DF, until F, the hypertectic point, is reached. This being the point of intersection with the second supersolubility curve, the second solid, N, begins to separate, and the whole of the mother-liquor solidifies at the constant temperature of the point F.

Taking the same mixture o , we may now assume that on reaching the temperature p , a crystal of M is introduced. This crystal grows, and the point representing the composition of the liquid moves along pC . When the eutectic point C is reached, however, the eutectic mixture does not solidify as a whole, as it is metastable as regards the substance N, the separation of M therefore continues in the direction CH. The temperature then falls until the curve EF is cut, crystallization of N begins, and continues until the hypertectic point is reached. The curve BC may similarly be prolonged into the metastable region, as shown by CG.

In the absence of mechanical disturbance, mixtures may even be cooled below the temperatures indicated by the curves DF and EF without crystallizing. Thus the mixture o may be cooled, under favourable conditions, below q , but crystallization is sure to begin before the undercooling has proceeded very far into the labile region, unless prevented by increasing viscosity. The heat developed causes the temperature to rise to q , and freezing then proceeds. Under similar conditions, however, the phase N may also fail to appear when F is reached, so that the labile prolongation FK may be experimentally realized. The curve EF may be similarly prolonged as at FL.

The formation of crystals on the upper curves takes place with comparative slowness, and the temperature may therefore fall low enough for the supersolubility curve to be intersected, before the separation of solid is complete. In that case, a further crystallization of the same solid phase, but now

proceeding rapidly from a large number of centres, may take place. Miers and Isaac found it easy to distinguish by inspection alone the crystals formed in the metastable region from the shower deposited on reaching the supersolubility curve.

It is clear from this description that the eutectic point C may entirely fail to appear on the cooling curve of a mixture. In one case, that of a mixture containing 90 per cent. salol and 10 per cent. betol, Miers and Isaac were even able to observe four freezing-points, none of which was the eutectic point. Representing such a mixture by r , the upper salol curve is crossed at s , at which point salol crystals may be obtained by inoculation. Crystals of betol are obtained at u by inoculation with that compound, whilst labile showers of the two components may be obtained spontaneously by cooling to t and v respectively.

When one or more of the components is capable of existing in polymorphic forms, the conditions become yet more complicated, since a metastable modification may crystallize from the liquid. This has been observed in mixtures of naphthalene and chloroacetic acid, the latter of which may crystallize in three modifications, each of which has its own supersolubility curve.¹

It is not known how far below the solubility curves the metastable limit is to be placed in the case of alloys, but microscopical evidence favours the view that the conditions prevailing closely resemble those just described. The cooling of a liquid metal or alloy below its freezing-point is a familiar fact, and even the addition of a crystal of the solid phase sometimes fails to remove the evidence of undercooling from the cooling curve. This is no doubt due to the comparatively slow growth of crystals in the metastable region, allowing the temperature to fall to the metastable limit before equilibrium is reached, a rapid separation of crystals from the labile liquid then taking place, with a corresponding rise in temperature.

The prolongation of a freezing-point curve into the metastable region, as at CG (Fig. 75), is very frequently observed. The effect on the cooling curve is to cause the eutectic arrest

¹ H. A. Miers and F. Isaac, *Phil. Trans.*, 1909, 209A, 337.

to come too late. When the method of thermal analysis is adopted, it is necessary to prevent this undercooling of the eutectic by inoculation with the second component, N, when the temperature corresponding with C is reached. In the absence of such inoculation, the duration of the eutectic arrest is diminished, causing inaccuracy in the eutectic time curve. The effect on the microscopic structure is to cause the crystals of M to occupy too large an area, the area of eutectic being correspondingly lessened. Undercooling may even proceed so far that the eutectic structure is absent from the section of the solidified alloy, especially when the constituent which crystallizes first is in large excess. As an example, the solutions of cuprous oxide in copper, which behave as true alloys, may be taken. The freezing-point curve, up to 9 per cent. Cu_2O , is shown in Fig. 76.¹ When the copper is in excess of the eutectic proportion, the freezing usually takes place normally, and the sections obtained show areas of copper and of the $\text{Cu}-\text{Cu}_2\text{O}$ eutectic.² The case is different, however, when the mixture is richer in oxygen, so that crystallization commences on the second branch of the curve. If slowly cooled, the crystals of Cu_2O continue to grow after the eutectic point is reached, and this process continues until nearly all the oxide has been removed from the liquid alloy. At this point, the supersolubility curve of copper is probably intersected, and practically pure copper solidifies around the skeletons of oxide.

An effect which is seen in the microscopic sections of many alloys may possibly be due to the same cause. This is the appearance of a band of the constituent N surrounding the crystals of M which had originally solidified, and separating them from the banded areas of eutectic. This is particularly well seen in alloys of copper with cuprous phosphide, and of copper with silver, containing copper in excess of the eutectic proportion.³ The effect may be due to the continued

¹ E. Heyn, *Zeitsch. anorg. Chem.*, 1904, **39**, 1.

² Giraud, *Rev. de Métallurgie*, 1905, **2**, 297.

³ A. K. Huntington and C. H. Desch, *Trans. Faraday Soc.*, 1908, **4**, 51.

separation of copper after passing the eutectic point, crystallization of the excess of the second constituent then taking place suddenly, forming an envelope, after which the eutectic composition is again reached, and simultaneous separation of the two constituents takes place in the normal manner. The fact, however, that the effect is only seen when the primary crystals are well-orientated skeletons, and never, in the author's experience, when isolated crystals are produced,¹

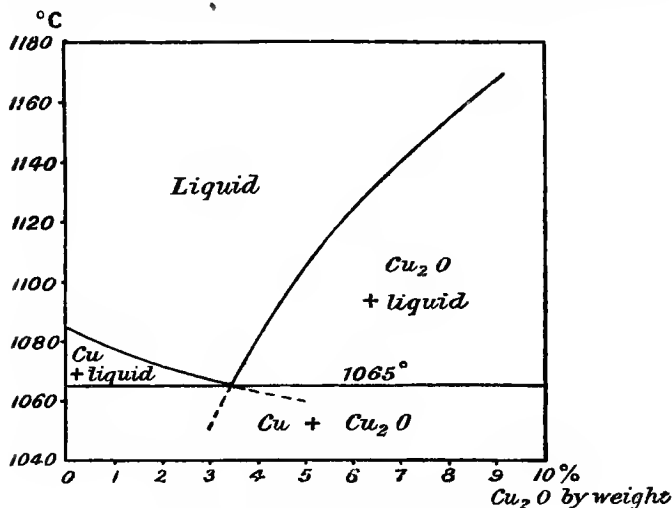

FIG. 76.—Copper and cuprous oxide.

suggests a different explanation, which is that proposed by Huntington and Desch, namely, that the envelope is due to segregation at the moment of solidification of the eutectic. The directive force of the copper crystals is great, and it would seem probable that when solidification of the eutectic begins, the copper particles are attached to the previously formed skeletons, thrusting aside the particles of phosphide, or of

¹ A similar band is seen surrounding the skeletons of iron in iron-phosphorus alloys, but not in those richer in phosphorus, in which the primary crystals are isolated rhombs of Fe₃P (J. E. Stead, *J. Iron Steel Inst.*, 1900, ii., 60). Segregated bands also surround the crystals of copper in alloys of copper and silver, as is seen in Plate III., A.

silver, etc., which have a less developed power of orientation. This process would continue until a layer of the second constituent had been formed, completely coating the skeletal, and the eutectic would then be free to assume the banded structure, with a general parallelism determined by the previous orientation. To decide the point, it remains to be determined whether the formation of the layer is inhibited by inoculation with the second constituent, so preventing undercooling.

Undercooling may also take place when the constituent crystallizing is a solid solution. In the only case which has yet been studied experimentally, that of mixtures of naphthalene and β -naphthol, the liquidus and solidus curves lie very close together, and the supersolubility curve lies about 3° below the latter, and parallel with it.¹ It was not found possible to determine the exact composition of the crystals separating from the undercooled solution. It would be of great interest to examine a case in which the liquidus and solidus curves are separated by a wide interval, as in the alloys of gold and platinum, and to determine whether the composition of the solid separating is given by the intersection of the solidus with the horizontal drawn through the point at which crystallization actually commences, or through the corresponding temperature on the liquidus, that is, the temperature to which the mixture rises as soon as crystallization in the metastable region has begun. The answer to this question is at present uncertain, although the microscopic appearance of such alloys would seem to render the former suggestion the more probable.

Should the chemical changes taking place during freezing be of a kind to require some time for their accomplishment, the occurrence of undercooling may result in an entire alteration of the form of the freezing-point curve. Such a case has been observed in the alloys of antimony and cadmium.² In the

¹ H. A. Miers and F. Isaac, *Trans. Chem. Soc.*, 1908, **93**, 927.

² N. S. Kurnakoff and N. S. Konstantinoff, *Zeitsch. anorg. Chem.*, 1908, **58**, 1. Compare W. Treitschke, *ibid.*, 1906, **50**, 218. The diagram is given by both observers in an incomplete form; it has been completed from their thermal and microscopical data.

diagram, Fig. 77, the full curve corresponds with the condition of stable equilibrium, and is only obtained after inoculation with crystals of the compound CdSb, the dotted curve representing a metastable condition realized in alloys cooled without stirring or inoculation. The stable curve has a maximum at 50 atomic per cent. Sb, with a eutectic point, CdSb—Sb, at 58.4 atomic per cent. Sb. In the absence of inoculation, however, the curve corresponding with the separation of free antimony is

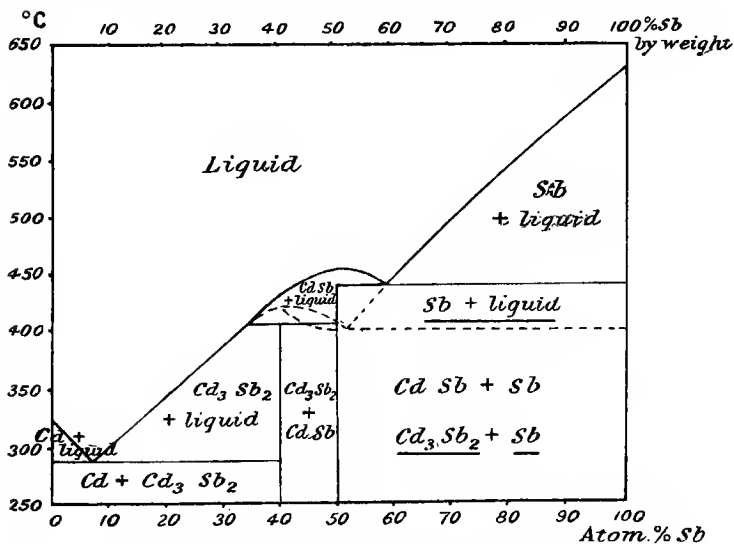
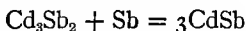

FIG. 77.—Stable and metastable systems in alloys of antimony and cadmium.

prolonged downwards, and when separation of a second solid phase does take place, it is not the stable compound, CdSb, that crystallizes, but the metastable compound, Cd₃Sb₂, which has its own solubility curve, with a maximum at 40 atomic per cent. Sb and 423°, 32° lower than the maximum on the stable curve. This is in accordance with the general rule that metastable modifications melt (or freeze) at a lower temperature than stable modifications.

-Consider now an alloy containing 53 atom. per cent. Sb.

If slowly cooled and inoculated, it deposits crystals of CdSb, and shows a eutectic point at 445°. If cooled without inoculation, crystallization does not set in until later, when antimony separates, and there is a eutectic arrest at 402°, corresponding with the simultaneous separation of Sb and Cd₃Sb₂. On further cooling, the reaction



occurs with considerable development of heat, and the solid alloy passes, more or less completely, into the stable condition. To the left of the vertical line at 50 atom. per cent. Sb, the compound Cd₃Sb₂ is stable at low temperatures. The development of heat is observed in metastable alloys containing between 40 and 50 atom. per cent. Sb, owing to the transformation of their excess Cd₃Sb₂. To the left of the line at 40 atom. per cent. Sb, again, Cd₃Sb₂ is alone stable.

A similar effect is observed in alloys of zinc and antimony;¹ but in this case it is the compound Zn₃Sb₂ which occurs at the maximum, and it is the compound ZnSb which is not deposited, unless crystals of it are used for inoculation.

Again, reactions which take place between the crystals which have separated at a higher temperature and the still liquid alloy, and are indicated by a break in the direction of the freezing-point curve (p. 36), are particularly liable to undercooling, as one of the reacting substances is solid, so that the velocity of the reaction is limited by the solution and re-deposition of the solid phase, or by the velocity of diffusion in the solid solution. Both of these processes are slow in comparison with that of crystallization. Very slow cooling and thorough agitation are therefore necessary if the reaction is to proceed to completion.

The possibility of undercooling is not confined to the passage from the liquid to the solid state, but is also associated with the physical and chemical changes taking place after solidification. A typical example is that of a solid solution breaking up into two constituents when cooled to a certain transformation temperature. It has been mentioned on p. 59

¹ S. F. Schemtschuschny, *Zeitsch. anorg. Chem.*, 1906, 49, 384.

that iron containing 0.89 per cent. of carbon is, at temperatures above 700° , a homogeneous solid solution. At 690° this solution resolves itself into a conglomerate, or eutectoid, of iron and iron carbide, Fe_3C , the process of resolution being completed at constant temperature under conditions favouring equilibrium. In the ordinary cooling of a bar of steel, as an iron-carbon alloy of such a composition is called, the temperature falls below that at which the change should take place, then rises to 690° , and continues at that temperature, the course of events bearing a complete resemblance to that already described in the freezing of an undercooled liquid. The amount of heat developed by the transformation is large, and when a bar of steel, of the stated composition, is cooled in air, the rise of temperature due to the change is sufficient to cause a visible brightening of the red glow emitted by the metal, if observed in a darkened room. The phenomenon, which was first observed by Barrett,¹ is due to the breaking up of the solid solution, martensite, into a mechanical mixture of pure iron (ferrite) and iron carbide (cementite). It has received the name of "recalescence," and the term has since been applied more generally to those developments of heat which occur during the cooling of many solid alloys. Very marked instances are observed in the ternary alloys used as fusible metals, which often show a sudden rapid rise of temperature during cooling, accompanied by a change of volume sufficient to cause the alloy to fly to pieces.²

The process of "quenching," so often applied to alloys both in metallographic investigations and in technical practice, consists in cooling a solid alloy through a critical range with such rapidity that the transformation which takes place on slow cooling is either entirely or partly suppressed,

¹ W. F. Barrett, *Phil. Mag.*, 1873, [iv.] 46, 472. The momentary elongation of a stretched steel wire on cooling to this temperature was observed by G. Gore, *Proc. Roy. Soc.*, 1869, 17, 260, and it was while investigating this volume change that Barrett observed the glow. The effect is easily shown as a lecture experiment.

² Erman, *Ann. Physik*, 1827, [ii.] 9, 557; R. Warrington, *Mem. Chem. Soc. Lond.*, 1843, 1, 77; Person, *Compt. rend.*, 1847, 25, 444; W. Spring, *Ann. Chim. Phys.*, 1876, [v.] 7, 178.

so that a phase which is stable only at some higher temperature is retained in the cooled alloy in a metastable or labile condition. To take an instance of the technical application first, the well-known hardening of steel by quenching depends on the suppression of the recalescence point by rapid cooling through the critical range. The solid solution of carbon in iron, which exists at high temperatures, is thus prevented from breaking up into free iron and the carbide, and so forming a conglomerate of greatly inferior hardness. Many copper alloys, especially those containing certain proportions of zinc, tin, or aluminium, may also be hardened by quenching, although not to so great an extent as steel. The mechanism of the process is in each case the same—the preservation by rapid cooling of a solid solution which is normally broken up in slow cooling before reaching the ordinary temperature.

Quenching is resorted to in metallographic researches as a means of investigating the nature of the phases existing at high temperatures. The examination of such phases at the temperature at which they are stable is in general impracticable, although the crystalline structure of iron at a red heat has been studied by etching with fused calcium chloride,¹ the etching figures thus produced being visible after cooling. This method is perhaps applicable in other cases, although the liability of heated metallic surfaces to become covered by a film of oxide is a source of difficulty. Apart from this treatment, the only means of obtaining information as to the microscopic structure of phases unstable at the ordinary temperature is that of quenching. Further, the physical and mechanical study of such undercooled phases and supersaturated solid solutions is one of great interest, and it is therefore desirable that the quenching process adopted should be applicable to specimens large enough for the purposes of physical and mechanical tests. The systematic investigation of alloys by quenching is explained in Chapter XIV.

In technical and ordinary laboratory practice, the metal or alloy is heated to the required temperature in a muffle or electric furnace, seized with heated tongs, and rapidly plunged

¹ E. H. Saniter, *J. Iron Steel Inst.*, 1897, ii. 115 ; 1898, i. 206, 275.

into cold water. As a method of research, such a procedure is quite insufficient. Cooling to an unknown and inestimable extent takes place during the opening of the furnace and the transfer of the specimen, so that the actual temperature of quenching is quite unknown. Better results are obtained by heating the specimen in a bath of fused salts, such as the alkali chlorides, borates, or silicates, or mixtures of these. Hardening furnaces of this type are now in use for technical purposes.¹ On removing the specimen, a film of salt, of low conducting power, remains adherent to the metal, and hinders the fall of temperature during the transfer to the cooling bath. This plan has been adopted by Le Chatelier in his researches on the quenching of tool steel.² It is, however, desirable that the transfer should be more rapid than is possible by such means. Benedicks, in a very thorough investigation of the quenching process,³ used a horizontal electric furnace of special construction, having a longitudinal slot in the under side for one-half of its length. The specimen, with a thermo-couple attached, was mounted on a pivoted arm. During heating it occupied the centre of the furnace, and when the quenching temperature was reached, the arm was released electrically and swung by a spring through a quarter-circle, passing through the slot and carrying the specimen downwards into the quenching vessel. This arrangement provides for a very rapid transfer of the specimen.

In ordinary practice small specimens may be quenched satisfactorily by employing a tube extending beyond the limits of the horizontal furnace, and provided with a T-piece directed downwards. The object is rapidly drawn by a platinum wire, or pushed by a quartz or porcelain rod along the tube, until it falls into the quenching liquid through the T-piece.⁴ As the tube may be closed with stoppers at both ends, the wire passing through a fine perforation, it is possible to work in an

¹ E. Sabersky and E. Adler, *Trans. Faraday Soc.*, 1909, 5, 15.

² *Rev. de Métallurgie*, 1904, 1, 184.

³ *J. Iron Steel Inst.*, 1908, ii. 152.

⁴ This device, without the addition of the T-piece, was employed in quenching specimens of cast-iron by P. Goerens, *Vorgänge bei der Erstarrung und Umwandlung von Eisenkohlenstofflegierungen*, Halle, 1907.

indifferent atmosphere, which is advantageous in experiments with steel, the surface of which is liable to become oxidized or decarburized.

Instead of removing the specimen from the furnace and transferring it to the cooling bath, we may admit the quenching liquid to the heated space. This method, which has only been rendered possible by the advent of fused silica as a common laboratory material, has been adopted by Rosenhain,¹ whose apparatus is illustrated diagrammatically in Fig. 78. A wide silica tube passes through a horizontal resistance furnace, and is fitted at one end with a large tap, A, and an arm bent at right angles. The other end is connected with a suction flask

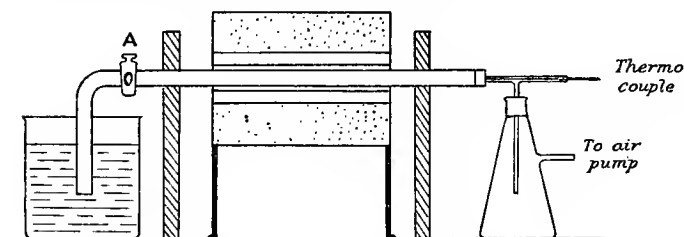

FIG. 78.—Rosenhain's quenching apparatus.

by means of a T-piece, through which the thermo-couple passes. The specimen, previously polished if necessary, is placed in the silica tube, and the stopcock is closed. The bent arm dips into a vessel of water. When heating begins, the flask and tube are exhausted by means of a Fleuss pump. When the pyrometer indicates that the desired temperature has been reached, the stopcock A is suddenly opened, when water rushes in to fill the exhausted space. The silica tube withstands the sudden cooling, and the specimen is driven by the inrush of water to the further end of the tube, where it is cooled very rapidly. Quenching takes place quietly, without explosive violence, and all exposure to the atmosphere is avoided, so that the surface of the alloy is perfectly protected from oxidation.

¹ *J. Iron Steel Inst.*, 1908, i. 87.

The taking of a cooling curve during quenching, although a matter of some experimental difficulty, is necessary if it is desired to know whether the recalescence has been entirely suppressed or not. The problem has been attacked by Le Chatelier,¹ and also by Benedicks (*loc. cit.*). The thermo-couple is enclosed in a thin iron tube, being held in a fixed position inside it by a plug of clay, introduced while moist and subsequently baked. The tube fits tightly into a hole bored longitudinally in the specimen, and the welded junction of the couple is in close contact with the latter. The entry of water at the joint is prevented by a coat of sodium silicate.

The galvanometer employed by Le Chatelier was insufficiently sensitive, and a great improvement was introduced by Benedicks, who used a sensitive string galvanometer of high resistance. In this form of instrument² a silvered quartz fibre, through which the current to be measured passes, is placed in a strong magnetic field, and its lateral displacement is made visible by means of a mirror. The magnified movements are recorded photographically. The resistance of such an instrument is so high that its readings are quite independent of changes in the resistance of the thermo-couple, and it responds with great rapidity to changes of temperature.

Both authors have compared the cooling effect of different liquids. The statement is often made in the older text-books, and is commonly believed by practical men, that the thermal conductivity determines the cooling power of the liquid, and various salts, etc., are added to water in tool-hardening shops for the purpose of increasing the conductivity. Exact experiment shows that this is a mistaken opinion, the cooling due to liquid conduction being, as might be expected, quite insignificant in comparison with that due to convection. The true determining factor is the specific heat of the liquid. Mercury, which is popularly supposed to have the greatest quenching power, is much less effectual than water. The addition of salts or acids to water has very little effect on the quenching power. The larger the quantity of liquid employed, relatively

¹ *Rev. de Métallurgie*, 1904, 1, 473.

² M. Edelman, jun., *Physikal. Zeitsch.*, 1906, 7, 115.

to the mass of metal or alloy, the more rapid the cooling. The most effectual quenching agents examined are the alcohols, and these may be expected to give the most complete suppression of the recalescence in experiments of the kind. Liquids at or near their boiling-point have a greatly reduced quenching power.

A liquid of low quenching power may be employed deliberately when it is desired to hinder complete transformation without entirely suppressing it. An instance of this is seen in the treatment of steel forgings for the manufacture of large guns. The forgings are heated to 920° , and are then rapidly lowered, in a vertical position, into a tank containing rape oil, a liquid of low cooling power, the tank being often contained in a water-jacket. Pumps may be used to produce a circulation of the oil, and so render the cooling of the mass uniform. The steel passes rapidly through the critical range, and the solid solution, stable at 920° , breaks up too rapidly to allow of a mechanical separation of the iron and carbide, such as takes place in slow cooling. The forgings are afterwards annealed, to remove strains produced by quenching.

The partial resolution of the solid solution in slowly quenched iron-carbon alloys results in the formation of very intimate mechanical mixtures of the constituents, apparently homogeneous in some cases, which have often been regarded as distinct phases, and have thereby introduced some confusion into the study of hardened steels. The iron-carbon equilibrium is discussed in Chapter XVII.

The phases retained by quenching are commonly spoken of as metastable, but, although experimental proof has not been produced, we are bound to assume that the metastable limit has been passed, and that the systems are correctly described as labile, and not as metastable. Quenched specimens therefore tend spontaneously to assume an equilibrium condition by undergoing the transformation which was suppressed by quenching. It is uncertain how far the spontaneous change can proceed at ordinary temperatures. White tin, which is only stable above 18° , does not change into grey tin at 0° unless brought into contact with the new phase. Below 0°

the change may occur spontaneously, although even at low temperatures it may fail to occur when the tin is kept for long periods.¹ The maximum velocity of transformation is near -45° .

Hardened steel is undoubtedly labile at the ordinary temperature; the presence of the stable phase is not necessary to initiate change. But there is little evidence that softening of the steel takes place spontaneously unless the temperature is raised. Japanese swords of the fifteenth century, if carefully preserved, are found to be as hard at the edge as if newly hardened; it would therefore seem that no appreciable return to the stable state takes place in the course of several centuries at atmospheric temperatures. On the other hand, prolonged heating of hardened steel even to 100° produces an appreciable softening, and heating to 150° , in a few minutes. The whole question of labile and metastable conditions in undercooled solid alloys demands fuller investigation. Certain conditions of physical, as distinguished from chemical, metastability are discussed in Chap. XVI.

¹ E. Cohen and C. van Eyck, *Zeitsch. physikal. Chem.*, 1899, **30**, 601; E. Cohen, *ibid.*, 1900, **33**, 59; **35**, 588; 1901, **36**, 513.

CHAPTER XI

DIFFUSION IN THE SOLID STATE

THE possibility of diffusion in the solid state has already been assumed in dealing with equilibrium in the crystallization of solid solutions and the reaction of a solid and liquid phase to form a compound. Many facts known to the technical metallurgist, and many isolated laboratory observations, point to the existence of such a process, but the earliest systematic and quantitative investigation bearing on the question is that described in the Bakerian lecture of Roberts-Austen for 1896.¹ An example taken from this research will indicate the nature of the process.

An alloy of lead and gold containing 5 per cent. Au is pressed tightly against one end of a cylinder of pure lead, the two surfaces in contact being accurately plane, and the cylinder is then heated at 165° for thirty days, after which it is sawn into sections, and the gold is estimated in each section by the ordinary methods of assaying. Such a cylinder, 0.64 cm. high, placed vertically with the gold alloy downwards, gave the following figures on assaying :—

No. of section from base.	Weight of section.	Per cent. Au.	Diffusivity.
	grams.		
1	0.64	0.039	0.005
2	2.33	0.030	
3	2.02	0.015	

¹ W. C. Roberts-Austen, *Phil. Trans.*, 1896, 187A, 383. See, for a summary and bibliography of the subject of diffusion in solids and glasses, C. H. Desch, *Brit. Assoc. Rep.*, 1912.

The number in the last column represents the diffusivity, expressed in sq. cm. per day, calculated by means of Fick's theory of diffusion (see Chapter XV.). The diffusion is still measurable at so low a temperature as 100°. At higher temperatures the process is much more rapid, so that gold is able to rise against gravity to a height of 7 cm. in lead at 250° in less than a month. The latter temperature, although 77° below the melting-point of lead, is above the eutectic temperature of the lead-gold series, and the possibility of the metal being transported in the form of a liquid eutectic alloy is therefore suggested; but the concentration of the gold is always far below the eutectic proportion, and in all probability below the limiting concentration of the solid solution of gold in lead. The following values were found for the diffusivity at different temperatures:—

251°	0'023, 0'030
200°	0'007, 0'008
165°	0'005, 0'004
100°	0'00002, 0'00002

The fact that smooth surfaces of lead and gold, pressed together *in vacuo* at 40° for four days, adhere so firmly that a force equal to one-third of the breaking stress of lead is required to separate them, seems to indicate that diffusion also takes place at the ordinary temperature.

Gold diffuses in silver at 800°, the diffusivity being of the same order as that of gold in lead at 200°. It had been shown in 1894¹ that carefully surfaced cylinders of copper and zinc, heated 6 or 8 hours at 400°, formed a layer of yellow alloy to a depth of 0·8 mm., and there is much evidence to show that the phenomenon is a very general one.

The diffusion of a substance into the interior of a solid metal assumes great importance in the technical conversion of iron into steel by "cementation." The iron is heated in powdered carbon, and diffusion takes place, causing carburization of the iron to a depth depending on the temperature and on the duration of the heating. A quantitative study shows

¹ W. Spring, *Bull. Acad. roy. Belg.*, 1894, [iii.] 28, 23.

that the carburization is a process of true diffusion, and the curve representing the distribution of carbon at different depths has the form of a diffusion curve.¹ The process has been explained as one of penetration of the iron by gases derived from the carbon, since gases, especially those containing nitrogen, undoubtedly have a great influence in certain forms of the technical process.² It is unnecessary, however, to assume that the gas passes into the metal as such, and there is much evidence that its effect is rather to produce a layer of highly carburized alloy on the surface, which forms the starting-point of the true solid diffusion, like the rich lead-gold alloy used in Roberts-Austen's experiments.

Much controversy has turned on the carburization of iron by diamond *in vacuo*, at a temperature much below the melting-point of the iron. The experiment was at first held to be conclusive,³ but later experiments have shown that traces of gas have a great influence in promoting cementation,⁴ whilst the actual contact of the specimens is also of great importance in ensuring a positive result.⁵ The most conclusive experiments are those of F. Weyl,⁶ who showed that cementation took place in a high vacuum if contact were maintained, but that the presence of a very thin intervening layer prevented any action. It is certain that the carbide first forms a solid solution with the iron, and that diffusion then takes place within the solid solution from places of higher to those of lower concentration, until a limit of saturation is reached. In accordance with this statement, carbon is found to diffuse, in the form of carbide, from a high-carbon steel into a specimen of soft iron placed in immediate contact with it.⁷

¹ R. Mannesmann, *Verh. Ver. Beförd. Gewerbeft.*, 1879, 58, 31; W. C. Roberts-Austen, *J. Iron Steel Inst.*, 1896, i. 139.

² For an account of the action of gaseous oxides of carbon as cementing agents, see F. Giolitti, *J. Iron Steel Inst.*, 1911, ii. 307; where previous papers by the same author are summarized.

³ W. C. Roberts-Austen, *Nature*, 1889, 41, 14; F. Osmond, *Compt. rend.*, 1891, 112, 578.

⁴ G. Charpy and S. Bonnerot, *Compt. rend.*, 1910, 150, 173.

⁵ L. Guillet and C. Griffiths, *ibid.*, 1909, 149, 125.

⁶ *Metallurgie*, 1910, 7, 440.

⁷ J. O. Arnold and A. McWilliam, *J. Iron Steel Inst.*, 1899, i. 85.

The earliest scientific record of the production of an alloy other than steel by a process resembling cementation is the observation by Faraday¹ that wires of steel and platinum could be welded in a bundle to form a rod, which on testing with acid proved to be an alloy. As the metals of the iron and platinum groups are known to form solid solutions with one another, there is no doubt that the welding depends on true reciprocal diffusion of iron and platinum. Many alloys have also been produced by bringing the two metals into intimate contact by the application of pressure, and heating the compressed mass to a temperature below the melting-point of the most fusible alloy of the series,² although the production of fusible alloys by this process is not evidence of diffusion, as an intimate mixture of fine particles will melt at or near the eutectic temperature (see p. 29). Microscopical examination shows that union takes place particularly between those metals which form inter-metallic compounds, but that the typical eutectic and other structures characteristic of solidified metals are not produced. The fact of union is most patent when metals which form coloured compounds, such as copper and zinc or copper and antimony, are heated together.

The superficial conversion of a metal into an alloy by surrounding the specimen with a metallic powder and heating to a temperature favourable to diffusion has received technical application in the coating of iron and other metals with zinc.³ The pieces of metal to be coated are packed loosely in zinc dust which contains sufficient zinc oxide to prevent caking, and are heated for several hours at 250–300°, the furnace being rotated to bring fresh material into contact with the surface. A microscopic section normal to the surface shows

¹ M. Faraday and Stodart, *Quart. J. Sci.*, 1820, 9, 319; reprinted in Faraday's *Experimental Researches in Chemistry and Physics*, 1859, p. 57.

² W. Spring, *Ber.*, 1882, 15, 595; *Zeitsch. physikal. Chem.*, 1888, 2, 532, 536; *Bull. Soc. chim.*, 1888, [ii.] 49, 215; *Bull. Acad. roy. Belg.*, 1883, [iii.] 5, 229, 492; W. Hallock, *Amer. J. Sci.* 1889, [iii.] 37, 402; *Zeitsch. physikal. Chem.*, 1888, 2, 378.

³ S. Cowper-Coles, *Electrochem. and Metall.*, 1904, 3, 828.

that the iron and zinc are united by a layer of zinc-iron alloy, although the temperature is much below the melting-point of zinc. A similar result is obtained when copper is used instead of iron, an outer layer of an alloy rich in zinc being formed, united to the copper by a layer containing a smaller proportion of zinc. Antimony, tin, or aluminium may replace zinc, the powdered metal being used either alone or mixed with its oxide or some inert matter to prevent caking.

It is possible that zinc vapour, which is given off freely below the melting-point of zinc, may be instrumental in the formation of the first coating. The subsequent production of a layer of alloy of the two metals is, as will be shown later, a process of true solid diffusion.

A few more instances of the penetration of solids into solids by diffusion may be mentioned. Sulphur diffuses into silver, blackening it to a considerable depth,¹ and even iron has been observed to penetrate into silver in the course of some years.² Both iron and platinum, heated in a mixture of carbon and silica, are converted into silicides.³ Porcelain heated in amorphous carbon or graphite at 1000–1500°, is blackened, and the material in the interior of the mass is proved chemically and microscopically to be pure carbon.⁴

A very remarkable instance is observed in the electrolysis of glass. If a cell, divided into two parts by a glass septum, is filled on one side with pure mercury and on the other with sodium amalgam, and a current passed tending to drive the sodium towards the mercury, the temperature being near 200°, electrolysis occurs, and sodium appears in the mercury on the further side of the septum,⁵ the glass remaining clear and

¹ Homberg, *Mém. Acad. Roy. Sci.*, 1713, 306 (published 1739). Homberg also observed that a complex mixture, consisting probably chiefly of a silver amalgam, passed through a plate of silver without rendering it brittle.

² J. H. Howell, *Nature*, 1906, 73, 464.

³ A. Colson, *Compt. rend.*, 1882, 94, 26.

⁴ R. S. Marsden, *Proc. Roy. Soc. Edin.*, 1880, 10, 712; J. Violle, *Compt. rend.*, 1882, 94, 28.

⁵ E. Warburg and F. Tegetmeier, *Ann. Physik.*, 1890, [iii.] 41, 1; repeated and confirmed by W. C. Roberts-Austen, *Proc. Inst. Mech. Eng.*, 1895, 238.



A. Diffusion of zinc into copper. $\times 30$.

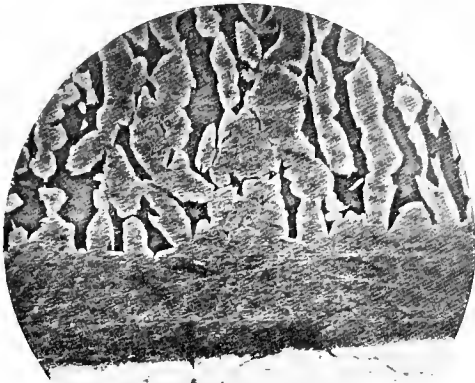

B. Diffusion of zinc into copper. $\times 30$.

PLATE X.

[To face page 221.]

unchanged. If lithium amalgam is substituted for sodium amalgam, sodium passes into the mercury as before, and lithium enters the glass in its place, the glass becoming opaque. When the opacity extends completely through the glass, lithium begins to appear in the mercury. If, however, potassium is used instead of lithium, the expulsion of sodium does not take place. The atomic volume of lithium is less, and that of potassium greater than that of sodium, and it appears therefore that a metal of small atomic volume is able to follow in the path of one of larger atomic volume, as if, as Roberts-Austen express it, actual galleries were formed in the glass by the sodium atoms, which could be traversed by smaller, but not by larger, atoms of a different element. This remarkable fact points to the importance of the atomic volume in the study of the characteristic behaviour of solids.

The process of diffusion may be most conveniently followed in a system in which several solid phases, distinguishable by the microscope, may be formed. Such a system is found in the alloys of copper and zinc. On immersing a rod of copper for a short time in molten zinc, an adherent coating is formed, consisting of a brittle silvery-white alloy rich in zinc. A section cut through the rod shows that within this layer is a layer of a yellow alloy, the β solid solution, which appears, under a low magnification, to be separated from the unaltered copper of the interior of the rod by a sharp boundary. This structure is shown in the photo-micrograph, Plate X., A, in which the upper band represents the outer layer, which consists, at least near its contact with the inner layer, of the γ solid solution. Next to it, and sharply divided from it, is a band of the β phase, and next to it again, separated by a very narrow dark band, is the core of unchanged copper.

If the rod is now heated for several hours at a temperature of about 700° , and then slowly cooled, diffusion is found to have occurred when the specimen is again examined, zinc diffusing inwards from regions of high to those of low concentration, that is, from the outer zone to the inner core. The γ zone gradually disappears, whilst the β zone undergoes a great extension of breadth, and also loses its original homogeneity,

showing isolated γ crystals near its outer margin and α crystals towards the inner margin, the latter becoming more and more closely grouped until a zone of the α solid solution is formed. This constituent being isomorphous with copper, it passes insensibly into the central mass, the transitional zone exhibiting a continuous change of colour from yellow to red. After further heating, the γ crystals disappear, and a broad band of β containing numerous α crystals forms the outer layer. This condition is seen in Plate X., B, where the upper band consists of $\alpha + \beta$, the intermediate zone of pure α , and the lowest of copper. If the experiment is repeated, using other metals in place of zinc, the outer layer is frequently found to break off before diffusion has proceeded very far, owing to the large increase of volume due to combination.

A conglomerate composed of particles of bismuth and thallium, rendered compact by pressure, proves convenient for the study of diffusion, owing to the formation of two coloured layers, one of which contains the compound Bi_5Tl_3 .¹ The diffusion may be detected by means of the microscope after a year at atmospheric temperature.

The most recent, and in some respects the most satisfactory, experiments are those of G. Bruni and D. Meneghini.² These authors employed metals of high melting-point, which form solid solutions without chemical combination, and they followed the progress of the diffusion by means of the change in the electrical conductivity. A nickel wire, 0.5 mm. diameter, was coated electrolytically with copper until the increase of weight corresponded with 59 per cent. copper and 41 per cent. nickel. The compound wire was then heated to 1000° in hydrogen, and the conductivity was determined from time to time. A slight increase of conductivity was noticed in the first hour, owing to the conversion of electrolytic copper into the better-conducting annealed form, but after this a continuous decrease of conductivity was observed, the minimum being practically reached after 140 hours, when the value

¹ G. Masing, *Zeitsch. anorg. Chem.*, 1909, **62**, 265.

² *Atti R. Accad. Lincei*, 1911, [v.] **20**, i. 671, 927; *Intern. Zeitsch. Metallographie*, 1912, **2**, 26.

attained was exactly that of a homogeneous alloy of the same composition. Exactly similar results were obtained when gold wires were coated with silver or copper. In a further experiment the area of contact of the two metals was greatly increased by coating a copper wire, 0.075 mm. diameter, with nickel and copper alternately, until thirty layers of each metal had been deposited. The thickness of the layers gradually diminished towards the outside, ultimately reaching a value of about 2.5μ . Such a wire became homogeneous, as shown by microscopical examination as well as by the determination of the conductivity, after less than two hours at 1000° , whilst diffusion proceeded at an appreciable rate at 500° .

SEGREGATION IN SOLID ALLOYS

The process of diffusion in solid alloys is further illustrated by the change known as segregation. If one of the solid phases present in the alloy is distributed in the form of minute crystals or crystallites, prolonged heating at a temperature below that at which any liquid is formed frequently results in the disappearance of many of the scattered particles, and in the formation of larger masses or crystals of the same constituent. An instance of this is the behaviour of iron-carbon alloys when heated below the critical point Ar_1 . Pearlite, which is the finely laminar eutectoid of iron and cementite, gradually loses its laminated character between 600° and 670° , the cementite "segregating" to form granular masses.¹ If the steel contains only about 5 per cent. of pearlite, the remainder being ferrite, the whole of the eutectoid may be broken up, so that the steel finally consists only of ferrite, containing a few isolated masses of cementite. Hence the apparent contradiction of the presence of structurally free ferrite and cementite in the same specimen,² the fact being that only the ferrite is a primary constituent, the eutectoid which originally accompanied it having disappeared through the segregation of its component particles. If the steel consists of pure pearlite, segregation does not proceed to the

¹ J. E. Stead, *J. Soc. Chem. Ind.*, 1903, **22**, 340.

² E. F. Lange, *Metallographist*, 1903, **6**, 9.

same extent, and the change ceases when the lamellæ have been replaced by granules of cementite. On the other hand, a steel containing an excess of cementite may undergo marked segregation, the whole of the pearlite being broken up, its component cementite uniting itself to the original cementite bands, and the ferrite forming broad envelopes around these.

The iron-iron phosphide eutectic behaves in the same way, the ferrite, containing 1.70 per cent. of phosphorus in solution, and the phosphide, Fe_3P , segregating to form broad bands.¹ Other eutectics, such as that composed of copper and copper phosphide, may also be rendered much coarser in structure by heating below the eutectic point.

The cause of segregation must be sought in the instability of minute crystals of a substance in presence of larger crystals of the same kind and of a solvent. The solubility of minute crystals of a salt in water is greater than that of larger crystals of the same salt. For example, calcium sulphate, CaSO_4 , $2\text{H}_2\text{O}$, in particles not less than $2\ \mu$ ($\mu = 0.001\ \text{mm.}$) in diameter, has a solubility in water at 25° of 2.085 g. per litre, whilst particles only $0.3\ \mu$ in diameter have a solubility of 2.476 g. per litre. Barium sulphate dissolves to the extent of 2.29 milligrams per litre when the diameter is $1.8\ \mu$, but of 4.15 milligrams per litre when it is $0.1\ \mu$.² Consequently, when small and large crystals of a salt are placed in a saturated solution of the salt in water, the smallest crystals dissolve. The solution then becomes supersaturated with respect to the larger crystals, which therefore increase in size, and continue to grow at the expense of the small crystals until the latter have been consumed. The same process occurs in solids. The larger crystals of the solid phase dispersed through the alloy grow at the expense of the smaller. The possibility of such a process presupposes a certain solubility of the particles in the intervening substance, and we must therefore assume, in the case of the iron-carbon alloys, a certain solubility of cementite in iron even below the critical point Ar_1 . This is in accordance with the experimental results of Benedicks and others.

¹ Stead, *loc. cit.*

² G. A. Hulett, *Zeitsch. physikal. Chem.*, 1901, **37**, 385.

The dispersion of a newly formed solid phase in an ultra-microscopic form through a crystalline mass of metal is not uncommon.¹ It is observed in alloys of nickel and iron, of cadmium and tin,² and also in the β solid solution of copper and zinc.³ This last case is of special interest. The β solution is not stable below 470° , at which temperature it is resolved into a mixture of the α and γ phases, which at first remain in a state of ultramicroscopic division. Segregation is extremely slow, even at temperatures only slightly below the transformation point, but is accelerated by the presence of the α or the γ phase in excess, or by the presence of a third metal in solid solution, such as aluminium.

The transfer of matter from the smaller to the larger particles can only take place by diffusion in solid solution, of which such segregation is a further instance. In reality, diffusion must take place whenever crystals are deposited from a solid solution. Just as, in the growth of crystals in a liquid, material for growth must be supplied from the surrounding solution by diffusion as that in the neighbourhood of the growing crystal is consumed, so the supply in a solid solution must take place in the same way. Convection currents, which also play a part in the crystallization from liquids, are of course excluded in the case of solids.

ANNEALING

The operation of annealing, performed on metals and alloys, consists in subjecting them to continued heating at a suitable temperature, below that at which any liquid phase is formed. If the specimen has previously been subjected to any kind of mechanical deformation by hammering, rolling, drawing, etc., the first effect of annealing is to remove the strains thereby produced. This effect will be discussed in Chapter XVI., in connection with the study of deformation. Strains may exist even in cast metals, owing to unequal velocities of cooling at different parts of the specimen, causing contraction to take place unequally.

¹ C. Benedicks, *Zeitsch. Chem. Ind., Kolloide*, 1910, 7, 290.

² W. Guertler, *Intern. Zeitsch. Metallographie*, 1912, 2, 172.

³ H. C. H. Carpenter, *Jour. Inst. Metals*, 1912, 7, 123.

Leaving aside the relief of mechanical strain, the effects of annealing are: to alter the size of the crystal grains, and to bring alloys to a condition of equilibrium by facilitating diffusion in the solid state.

It is well known that a metal or alloy may be rendered coarser in grain by prolonged heating at a sufficiently high temperature. Thus the size of grain of almost pure iron increases with the temperature. Recrystallization proceeds rapidly at 730° , so that after twelve hours the individual grains are visible without magnification.¹

The growth of crystals in lead may be observed even at 60° , if the metal has been previously strained.² The increase of coarseness brought about by the annealing of solid solutions, such as the α solution of ordinary brass, is very pronounced.³ The process of recrystallization may be watched by re-etching lightly a marked area of the specimen after successive periods of heating in a neutral atmosphere, so as to avoid any alteration in the surface composition. The growth is found to begin at a few centres, the crystals from which it proceeds increasing in size at the expense of their neighbours. It is the larger crystals which absorb the smaller, and the process has therefore a great similarity to the segregation of cementite in steels, although in the present instance the system is a homogeneous one, solvent and solute being identical. The recrystallization of a solid, the smaller grains being absorbed by the larger, is not confined to metals, having been observed in glacier ice at a temperature just below 0° .⁴

The principle of differing solubility is rejected as an explanation by G. Tammann,⁵ who assumes that the surface tension, which is less than the forces producing rigidity in a crystal at the ordinary temperature, may become much more considerable with increase of temperature. When the surface

¹ J. E. Stead, *J. Iron Steel Inst.*, 1898, i. 145.

² J. C. W. Humfrey, *Phil. Trans.*, 1902, 200A, 225.

³ G. Charpy, *Bull. Soc. d'Encouragement*, 1896, [v.] 1, 180; *Étude des Alliages*, 1; G. D. Bengough and O. F. Hudson, *J. Soc. Chem. Ind.*, 1908, 17, 43, 660; *J. Inst. Metals*, 1909, i. 89.

⁴ E. Hagenbach, *Zeitsch. Kryst. Min.*, 1892, 20; *Rapp. Congr. Intern. Phys.*, 1900, ii. 413.

⁵ *Zeitsch. Elektrochem.*, 1912, 18, 584.

tension exceeds the opposing forces, two crystals unite as two drops of fluid would do. The hypothesis is ingeniously applied to explain the recrystallization of strained metals.

The diffusion brought about in a heterogeneous alloy by annealing is of greater importance from a metallographic point of view. A cast alloy is not, in general, in a state of complete equilibrium, the velocity of cooling under ordinary conditions being greater than that of the reactions occurring in the solid state. It is therefore necessary in the majority of cases to subject the specimen to further thermal treatment in order to bring about equilibrium, especially when it is intended to use the alloy subsequently for the purpose of determining its physical properties.

An alloy consisting of a single solid solution, if rapidly cooled, shows a cored structure due to a difference of composition between the crystals first deposited and the layers subsequently deposited on them, as explained in the last chapter. The effect of annealing in this case is to increase the molecular mobility and thus to facilitate diffusion. The higher the temperature, the more readily the equalization of composition by diffusion can take place, and the shorter is the period of annealing which is necessary. The cores in an α solution of copper and tin disappear after annealing at 750° for three hours.¹

If the alloy consists of two solid solutions, the annealing process, by removing supersaturation, brings the relative proportions of the two constituents to those demanded by equilibrium. An alloy of 60 per cent. Cu and 40 per cent. Zn, rapidly cooled, consists only of the β solution, which exists at the ordinary temperature in a supersaturated or metastable state. If heated to a temperature below the transformation point (about 740°) crystallization of the α constituent takes place, and continues until the proportions corresponding with the solubility of α in β have been attained. By annealing for a period insufficient to bring about complete equilibrium, proportions of α less than the theoretical are obtained.

The annealing temperature for alloys composed of two solid solutions should therefore be slightly below the transfor-

¹ A. Portevin, *Rev. de Métallurgie*, 1909, 6, 813.

mation temperature, if the object of the annealing is to bring the alloy into a condition of equilibrium. A lower temperature will often suffice if the heating is continued for a longer time.

Annealing at too high a temperature may result, not only in the production of an excessively coarse structure, but in the separation of the crystal grains, the metal or alloy being traversed by numerous fissures following the boundaries of the crystalline polyhedra. Such a coarse, fissured structure is characteristic of "burnt" steel and brass. The effect is due to the production of gas at the boundaries, which, in forcing its way out of the metal or alloy, separates the grains. Iron or steel becomes "burnt" in an oxidizing atmosphere, oxygen entering the mass and combining with the carbon present, forming carbon monoxide, the escape of which produces the fissures. The very similar structure observed in overheated brass is probably due to the volatilization of a part of the zinc, solid solutions of zinc in copper having an appreciable vapour pressure below their melting-point. A coarse structure, exhibiting gaps between the grains, and a pitted surface, are characteristic of "burnt" metals.

TEMPERING

The process of tempering applied to steels may be regarded as a special form of annealing, arrested at a point short of complete equilibrium. A steel having been quenched from a temperature above the critical point is hard, and contains carbon in a state of solid solution. If re-heated to a temperature near the critical point, the supersaturated solid solution is resolved into its constituents, ferrite and cementite. If the re-heating is conducted at a much lower temperature, the resolution is only partial, and a part only of the carbide is set free, the remaining carbon being still retained in solution. The hardness and brittleness of the quenched steel are therefore diminished, but not completely destroyed. The heating is insufficient to cause segregation, so that a pearlitic structure is not produced, and the carbide thrown out of solution remains disseminated through the steel in a finely granular, or even ultra-microscopic condition. The higher the tempering temperature, the larger the quantity of carbide set free in this

disseminated condition, and the less the quantity retained in solution. The desired degree of softness is obtained by controlling the temperature of re-heating, which is determined in practice by the tint produced by the oxidation of the surface. The tints observed correspond with the following temperatures¹ :—

Colour.	°C.
Pale yellow	220
Straw yellow	230
Full yellow	243
Brown	255
Brown and purple	265
Purple	277
Bright blue	288
Deep blue	293
Dark blue, nearly black	316

The tints are interference colours, due to the formation of a transparent film of oxide. In modern practice, the use of salt baths, the temperature of which is maintained constant at the required value, is to some extent superseding the empirical control of the tempering process by observation of the heated surface, but the importance of the temper colours is nevertheless very great. The alteration of colour is due to the increase in thickness of the film of oxide, and this increase must take place by diffusion within the solid. Proceeding very rapidly at first, the process of diffusion soon reaches a limit, so that the film does not continue to increase in thickness to any appreciable extent after a time. Since the colour is a very accurate indication of the temperature to which the metal has been heated, it has been maintained² that oxidation must cease when a certain limiting depth, dependent only on the temperature, is reached. This is not the case; prolonged heating at a given temperature leads to the production of a film corresponding in thickness, and therefore in colour, with a higher temperature. The exact law of the rate of oxidation is unknown. At incipient redness the film becomes so thick as to be brittle and detachable.

¹ H. M. Howe, *Metallurgy of Steel*, 2nd ed., i. 23 (New York, 1891).

² C. Barus and V. Strouhal, *Bull. U.S. Geol. Surv.*, 1886, 27, 51; C. Barus, *Nature*, 1889, 41, 369.

CHAPTER XII

THE PHYSICAL PROPERTIES OF ALLOYS

THE thermal behaviour of metallic alloys with changing temperature, and the microscopic appearance of the solidified mixtures, are properties which lend themselves so conspicuously to the systematic investigation of alloys that the term "metallography" has been confined by some to these two departments alone. There is, however, no legitimate reason for thus restricting the scope of the science. Historically, an important part has been played by the study of the electrical conductivity and electrolytic potential, and many other methods have been employed from time to time. It is true that no other property has shown so close a connection with constitution as to give unambiguous results in all cases, but there are several, the determination of which has high auxiliary value. In complex instances, such as alloys containing several series of solid solutions, it is often difficult to determine, on thermal and microscopical grounds alone, whether inter-metallic compounds are present or not. The occurrence of a discontinuity in some other physical property, such as the hardness or the electrolytic potential, will often serve to decide the point.

In addition to its value in providing auxiliary methods of research, the study of the physical properties of alloys is of importance in quite another direction. The practical utility of alloys is dependent on their possession of certain physical characteristics, which in fact determine the employment in industry of alloys in place of pure metals. It is important, therefore, to establish such a relation between the constitution of a series of alloys—most conveniently expressed in the form of the thermal

equilibrium diagram—and their physical properties, that the latter may be predicted for any given alloy by an inspection of the diagram. This is now in many cases possible with a fair degree of accuracy, although the supply of the necessary data is still far from adequate. Only a small proportion of the data found in the literature, especially in physical journals, can be utilized, the experiments having been performed in so many cases with material of insufficient homogeneity. Defects, such as porosity, exercise an enormous influence on the density, conductivity, etc., of the specimens examined, whilst presenting only a slight inconvenience in the microscopical study, and being without effect in the thermal investigation. There is little doubt that alloys intended for physical examination should, if comparable results are to be obtained, be brought to their maximum density by mechanical compression sufficient to remove all pores, and should then be freed from strain by thorough annealing. Apart from the difficulty of such an operation with small quantities of material, the brittle and friable qualities of many alloys render such treatment impossible. These considerations explain the wide divergences between values obtained by different investigators, and purporting to refer to the same alloy. It should be added that general agreement has not yet been reached as to the means to be adopted in measuring certain properties, notably hardness and electrolytic potential, and results obtained by different methods are not always comparable.

The physical properties which have been brought into closest relation with the constitution are: (1) density; (2) thermal expansibility; (3) hardness; (4) electrical conductivity; (5) thermo-electric force; (6) magnetic susceptibility; (7) electrolytic potential. The last of these, on account of its importance in relation to the chemical properties, will be considered separately in the next chapter. The specific heat and the heat of solution have also been employed, but without any definite results. The latter of these will be discussed briefly in connection with the electrolytic potential. The vapour pressure of amalgams will be considered in dealing with the molecular condition of dissolved metals.

DENSITY AND SPECIFIC VOLUME

The density of a metal or alloy, that is, the mass of a unit volume, is dependent on the temperature and also on the mechanical condition of the body, a rolled or hammered metal, for instance, having a different density from one cast or annealed. The first effect of applying a pressure exceeding a certain limit is to produce an increase of density, which persists after the load is removed. This increase is only apparent, and is merely due to the closing up of previously existing pores and cavities, which are usually present to an unexpected extent, even in apparently homogeneous materials. A pressure of 10,000 atmospheres has been found sufficient in the majority of the cases examined to produce this effect, the compressed substances behaving as perfectly elastic bodies towards any further increase of pressure, however long continued.¹ This is only true if polymorphic change, which is brought about in many substances by the application of pressure, is absent. Further, it only holds good of pressure applied equally in all directions. When a solid is subjected to rolling, drawing, or hammering, the compression is accompanied by change of form, and when this takes place under great pressure, an actual diminution of density is found. This fact is known in workshops where wire is drawn, and it has been accurately studied in a number of cases.² • The meaning of the phenomenon will be discussed subsequently in connection with the plasticity of metals. In all cases in which a diminution of density is produced by deformation, annealing at a temperature well below the melting-point causes a return to the maximum density. This fact has been established by Spring and by Kahlbaum. A metal or alloy which

¹ W. Spring, *Bull. Acad. roy. Belg.*, 1883, [iii.] 6, 507.

² G. W. A. Kahlbaum, K. Roth, and P. Siedler, *Zeitsch. anorg. Chem.*, 1902, 29, 277; W. Spring, *Bull. Acad. roy. Belg.*, 1903, 1066; G. W. A. Kahlbaum, *J. Chim. Phys.*, 1904, 2, 537; G. W. A. Kahlbaum and E. Sturm, *Zeitsch. anorg. Chem.*, 1905, 47, 217; J. Johnston and L. H. Adams, *J. Amer. Chem. Soc.*, 1912, 34, 563.

has been thoroughly compressed by drawing or hammering, and subsequently annealed, is therefore likely to give the true density. It must be noted that even this precaution does not exclude every source of error, as the original metal may contain bubbles of gas, which will be compressed to very small dimensions, but will recover their original volume on annealing, causing the observed density to be too low.

Although the density of a body is properly the mass of unit volume, and the specific gravity is the ratio of the mass of the body to that of an equal volume of water, the two magnitudes are expressed by the same number when metric units are employed, and the Archimedean method, which consists in comparing the weight of the specimen with that of the water which it displaces, is therefore the best adapted to the study of the density of alloys. The principal error in this method is due to the suspending hair or wire. It has been found¹ that the most uniform results are obtained when the specimens are suspended by a platinum wire, 0.32 mm. in diameter, carefully platinized by electrolysis, washed, and dried, all contact with its surface being avoided. The specific gravity is then given by the formula

$$s = \frac{w}{w - w_1} (G - \lambda) + \lambda$$

in which s is the specific gravity referred to water at 4°, w and w_1 are the weights of the specimen in air and in water respectively, G is the density of the water at the temperature of the experiment, and λ the density of the air.

If the alloy is one which is acted on by water, the weighing is performed in some inert liquid, such as petroleum, the density of the liquid being inserted in place of G in the above formula. Liquid amalgams are weighed in a pyknometer.

When comparing the members of a series of alloys, however, the magnitude selected is not the density, but its reciprocal, the specific volume. If a series of alloys consists, as in the simplest case, entirely of conglomerates of crystals of the two

¹ Kahlbaum and Sturm, *loc. cit.*

components, the specific volume of any alloy will be that calculated from the specific volumes of the component metals and the proportions in which they are present, whilst there is no such direct relation between the densities. The specific volume-concentration curve is therefore, in the case of conglomerates, a straight line. This is found to be true with a fair amount of accuracy when percentages by weight, and not atomic percentages, are taken as abscissæ.¹

In the table, which has been constructed from Maey's figures, the constants of the linear equations, $v = a + bp$, are given for a number of pairs of metals, the alloys of which are known, from other evidence, to consist of conglomerates of the pure component metals, or of solid solutions of limited concentration. In the equation, v is the specific volume of an alloy and p the percentage by weight of the second metal, a being the sp. vol. of the first metal, and $b =$ the difference of the sp. vols. of the two metals $\div 100$. The fourth column contains the values of $100\Delta v/v$, where Δv is the greatest deviation from the calculated value shown by any alloy of the series, and v is the specific volume of that alloy. $100\Delta v/v$ therefore gives the greatest percentage deviation observed.

Metals.	a	b	$\frac{100\Delta v}{v}$
Bi - Cd	0·10181	0·0001373	- 0·1
Bi - Sn	0·10181	0·0003530	+ 1·0
Cd - Sn	0·11554	0·0002156	+ 0·5
Pb - Cd	0·08791	0·0002763	+ 0·4
Pb - Sb	0·08791	0·0006106	+ 0·9
Pb - Sn	0·08791	0·0004919	+ 0·9
Pb - Ag	0·08791	0·0000760	+ 0·7
Ag - Bi	0·09550	0·0000630	- 0·4
Sn - Zn	0·13710	0·0000400	+ 0·5
Hg - Pb	0·07368	0·0001422	- 1·0
Hg - Sn	0·07368	0·0006345	- 0·9

¹ A number of determinations were made by A. Matthiessen, *Phil. Trans.*, 1860, 150, 177; who, however, expressed his results as densities. The largest mass of data is found in a series of papers by E. Maey, *Zeitsch. physikal. Chem.*, 1899, 29, 119; 1901, 38, 289, 292; 1904, 50, 200. Maey recalculated the older figures of Matthiessen and others, expressing the results in terms of specific volume, and also made many new determinations.

Considering the difficulties of the determinations, the agreement within 1 per cent. must be considered satisfactory.

A solid solution is formed, as a rule, from its components without change of volume.¹ The following instances of metals forming unbroken series of solid solutions indicate that in these typical alloys at least the volume changes are inappreciable:—

	<i>a</i>	<i>b</i>	$\frac{100\Delta v}{v}$
Au — Ag	0'05191	0'0004309	+ 0'2
Ir — Pt	0'04461	0'0000190	± 0'2

The method of specific volumes is therefore incapable of distinguishing between conglomerates and solid solutions. On the other hand, series of alloys containing inter-metallic compounds show specific volumes which at certain concentrations deviate in a marked degree from the values calculated by the linear relation. A stable compound, formed with development of heat, might be expected to have a smaller volume than that of its components. It is, however, remarkable that in several cases a marked expansion has been observed, instead of a contraction, at compositions corresponding with compounds, although it may prove that some of the alloys of which this is reported were porous, and thus gave too low a density. In the table on p. 236, some cases are collected of pairs of metals, the alloys of which show marked contraction or expansion. The second column gives the composition of the alloy which exhibits the greatest deviation, the third column gives the molecular formula most nearly corresponding with that composition, and the last column, as before, the greatest percentage deviation of the specific volume from that demanded by a linear relation.

In many series, as in the alloys of zinc and copper, the deviations, although considerable, do not indicate any distinct

¹ Solid solutions of isomorphous salts show a strictly linear relation between specific volume and concentration. J. W. Retgers, *Zeitsch. physikal. Chem.*, 1889, 3, 497.

		Formula.	$\frac{100\Delta v}{v}$
Ag - Sn	70.8 percent. Ag	Ag ₃ Sn	- 5
Cu - Sn	39.0 " Sn	Cu ₂ Sn	- 9
Sb - Fe	40 " Fe	Fe ₃ Sb ₂ ¹	- 14
² Al - Sb	18 " Sb	AlSb	+ 24
Zn - Sb	45 " Zn	Zn ₃ Sb ₂	+ 5
Ag - Zn	71 " Zn	AgZn ₄	- 2

break in the curve at a definite composition, and it is impossible to assign a formula on the ground of density measurements. Assuming it to be true that a discontinuity in the specific-volume curve always indicates the existence of a compound, it does not by any means follow, as supposed by Maey, that the discontinuity will occur exactly at the composition of the compound. This is only true if solid solutions are not formed. This is, however, rather the exception than the rule, the majority of inter-metallic compounds being able to retain a greater or less quantity of one or both components in solid solution. The effect on the specific volume may be illustrated by an example. In Fig. 79, the upper part represents the thermal diagram of a series of alloys of the metals A and B containing a compound, C, which is capable of forming solid solutions up to the limiting concentrations D and E respectively. We will assume that B has a greater specific volume than A, and that the compound C is formed with contraction. All solid alloys between A and D will consist of conglomerates of A and the saturated solution D, their specific volumes will therefore follow a linear law, as indicated in the lower half of the diagram. At D the last crystals of A disappear, and between D and E the alloys consist only of the solid solution, of progressively changing concentration. As the percentage of B,

¹ Maey gives the formula FeSb for this compound, placing the discontinuity at 33.8 per cent. Fe. The figures agree better, however, with the formula Fe₃Sb₂, the curve at this part of the diagram being irregular. The existence of Fe₃Sb₂ is probable from the thermal results (N. S. Kurnakoff and N. S. Konstantinoff, *Zeitsch. anorg. Chem.*, 1908, 53, 1).

² E. van Anbel, *Compt. rend.*, 1901, 132, 1266.

the metal of greater specific volume, increases, the specific volume of the solid solution increases also. From E to B the alloys consist of conglomerates of B and the saturated solid solution E, and the specific volume consequently varies again

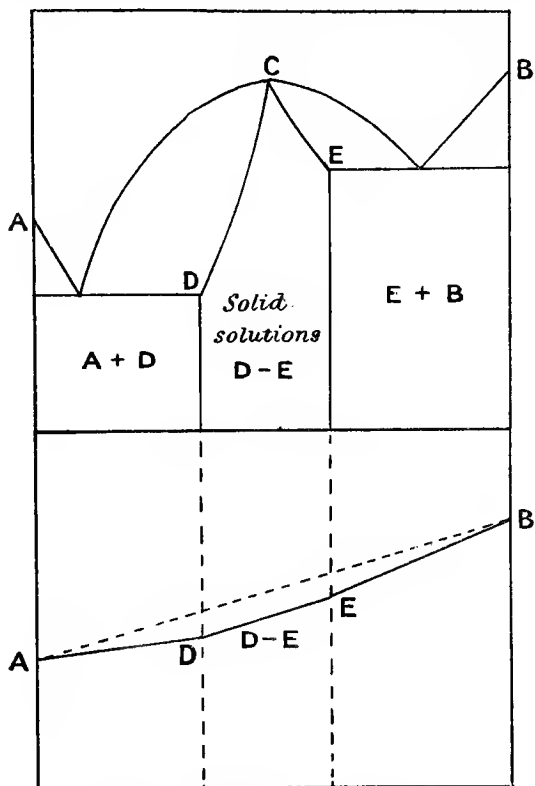

FIG. 79.—Constitution and specific volume.

in a linear manner. The specific-volume curve, therefore, exhibits two discontinuities, corresponding, not with the compound C, but with the limits of saturation of the solid solution. From an inspection of the curve, nothing could be inferred as to the composition of the compound, except that it lies between

the limits D and E. The rule that a discontinuity in a physical property indicates the appearance of a new solid phase, and does not without further evidence yield the formula of the compound present, applies to the electrical conductivity, hardness, etc., and especially to the electrolytic potential of alloys, as well as to their density. Neglect of this truth is responsible for the appearance, in chemical literature, of a very large number of inter-metallic compounds which have no real existence.¹

To sum up, the specific volume varies with the composition within a series of alloys as follows:—

1. In conglomerates of two constituents, the variation is linear. The small deviations observed are probably due to want of homogeneity.

2. In a series of solid solutions, the variation is almost linear. Further investigation may perhaps reveal some exceptions.

3. In a more complex series, discontinuities occur at each point of appearance of a new solid phase. Phases containing inter-metallic compounds have usually a smaller, but in a few cases a larger, specific volume than their components.

THERMAL EXPANSIBILITY

The change in the coefficient of expansion with change of composition in a series of alloys has remained practically unused as a method of investigating constitution. There is no reason why the method should not be applicable, and it is probably only the troublesome nature of the experiments, which require a well-equipped laboratory for their performance, that has hindered its use.² The expansion with increase of temperature and contraction on cooling has, however, rendered

¹ C. H. Desch, *J. Inst. Metals*, 1909, i. 227.

² For a few such measurements, see H. Le Chatelier, *Étude des Alliages*, 387 (Paris, 1901). Alloys of copper with antimony and with aluminium were studied by the optical method, maxima being found at points in the expansion curves corresponding with the compounds Cu_2Sb and Cu_2Al . A few measurements of this kind were made by A. Matthiessen, *Phil. Trans.*, 1866, 156, 861.

great service in the detection and fixing of critical or transformation points in metals or alloys capable of existing in polymorphic forms. A substance, such as platinum, which may be heated through a great range of temperature without undergoing change, increases in volume in a regular manner, the volume at a given temperature being given by a relation of the form

$$V = V_0(1 + \alpha t + \beta t^2)$$

the curve being a smooth parabola. Any polymorphic change taking place in the metal is indicated by a discontinuity in this curve at the temperature of the change. Observations of expansion are particularly valuable as a check on thermal analysis in cases of polymorphism, since a change accompanied by a very small development of heat may be accompanied by a marked alteration in volume, and *vice versa*. When volume- and energy-changes are both absent, there is a strong presumption against polymorphism.

At moderate temperatures, volume-changes are most conveniently measured in a dilatometer. The metal is enclosed in a glass (or, better, quartz) bulb fitted with a stem. The bulb and part of the stem are filled with a liquid which does not act on the metal, and the level at each temperature is read by means of a scale and telescope.¹ This method has been used to determine the transition-point between grey and white tin, which is thus fixed at 18°, in agreement with the electrolytic results.² It has also proved useful in the investigation of amalgams.³

When small bars of the metal or alloy can be accurately prepared and shaped, the expansion is best measured on a small prism, one end of which is polished and placed in contact with an optically worked, very flat convex lens of glass. The Newton's rings produced when a beam of monochromatic light is reflected from the metal after passing through the lens alter

¹ For a description of the method, see Ostwald and Luther, *Physico-Chemical Measurements*, and Findlay, *Phase Rule*, 293.

² E. Cohen, *Zeitsch. physikal. Chem.*, 1899, 30, 601.

³ H. Bijl, *Zeitsch. physikal. Chem.*, 1902, 42, 641.

in diameter as the temperature is raised, and their diameter is measured by suitable optical means.¹

The dilatation method has been most extensively applied in connection with the transformation-points of the alloys of iron. H. Le Chatelier (*loc. cit.*) used a method depending on the difference in expansion of the metal under investigation and a standard material (hard Sèvres porcelain). The samples examined were $70 \times 10 \times 5$ mm. in size, and their displacement relatively to the porcelain standard was measured by the movement of a mirror.

A similar method, very simple in its application, and suitable for work in a metallographic laboratory, was employed in detecting the abrupt changes in length which take place in the

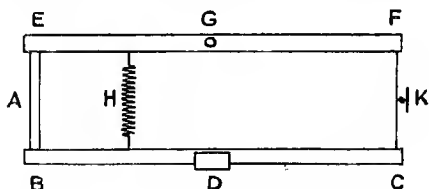

FIG. 80.—Simple form of dilatometer.

cooling of iron containing carbon.² A bar of the metal under investigation, A (Fig. 80), is placed between two porcelain rods, BC and EF, the first of which is fixed rigidly at D, whilst the second is free to move in a horizontal plane about a pivot at G. The ends of the rods are pressed against the specimen by a spring at H. Any movement of F relative to C, due to an alteration in length of A, is communicated to the mirror K, attached to a vertical torsion fibre. A ray of light reflected by K on to a scale magnifies the movement of F. The bar A is heated in a furnace, and simultaneous readings of the temperature and the scale deflection are made. The apparatus is easily rendered self-recording.

An apparatus susceptible of greater accuracy, and yielding an autographic record lending itself well to the recognition of

¹ H. Le Chatelier, *loc. cit.*

² G. E. Svedelius, *Phil. Mag.*, 1898, [v.] 46, 173.

critical points, has been devised¹ in which the expansion of the specimen is compared with that of a tube of pure silver of the same length. The arrangement of the bodies to be compared is shown in Fig. 81. The outer tube is of hard porcelain. Within it rests a tube of silver fitted with a collar, on which rests a porcelain tube of the same diameter. The specimen to be examined stands vertically inside the silver tube, and has the same height as it. A porcelain rod rests on the specimen. This rod and the inner porcelain tube are connected each with the short arm of a lever carrying a recording-point, which presses on a revolving drum on which paper is fixed. Each point therefore traces a separate curve on the paper. One of these curves records the expansion of the silver comparison tube, the other that of the body studied. Any irregularity of expansion of the porcelain is eliminated from the results, as both curves are equally affected. The apparatus might easily be adapted to trace a single curve corresponding with the differences in the movements of the two bodies. The outer tube stands in a vertical furnace, and the temperature is measured by a pyrometer introduced into the expansion apparatus.

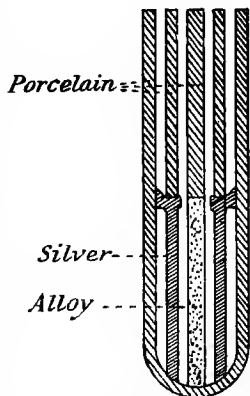

FIG. 81.—Sahmen and Tammann's dilatometer.

Fig. 82 represents some of the results obtained with iron containing different quantities of carbon.² The change on heating is marked by a contraction, which is near 900° for almost pure iron, becoming lower with increasing carbon content, whilst alloys containing an appreciable amount of carbon exhibit a strong contraction near 700° , this being the only change in the 0.64 per cent. C steel.

¹ R. von Sahmen and G. Tammann, *Ann. Physik*, 1903, [iv.] 10, 879.

² G. Charpy and L. Grenet, *Bull. Soc. d'Encouragement*, 1903, 102, 464, 883.

The volume-changes in an alloy which undergoes molecular changes on heating are sometimes very large. Thus Rose's fusible alloy expands up to 44° , then begins to contract, the contraction continuing until 69° is reached, and then expands, the prolongation of the original curve not being

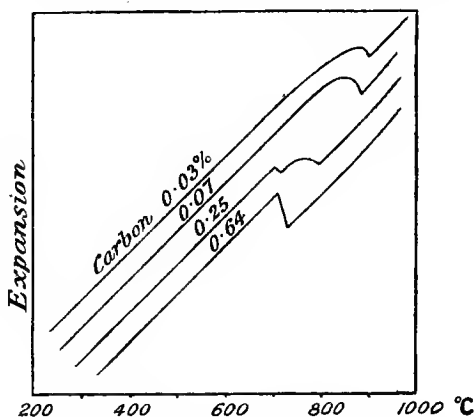

FIG. 82.—Expansion curves of steels.

reached until 98° (the melting-point). The volume at 69° is much less than that at 0° .¹

The change of volume which takes place on the passage from the solid to the liquid state has been measured in a few cases. As a rule, a metal occupies a greater volume at its melting-point in the liquid than in the solid state. Bismuth and certain alloys contract on melting, and their melting-point, like that of ice, is therefore lowered by pressure.

The percentage increases of volume on melting are:²

Lead	3'39	Potassium	2'6
Cadmium	4'72	Mercury	3'67
Tin	2'80	Bismuth	-3'29
Sodium	2'5		

¹ O. D. Chwolson, *Lehrb. der Physik.*, vol. iii.

² G. Vincentini and D. Omodei, *Atti R. Accad. Sci. Torino*, 1887, 23, 1; M. Töpler, *Ann. Phys.*, 1894, [iii.] 53, 343.

HARDNESS

Although the hardness of a solid is one of its most important physical characters from a practical point of view, it is one to which it is difficult to assign a definite scientific meaning, and several quite distinct magnitudes are in fact comprehended under the same general term. So far, it has not been found possible to express hardness in any scientific unit, and the numbers used to describe the hardness of a substance are therefore purely empirical, and refer only to one particular method of testing. These methods may be classified according to the kind of resistance they measure—

1. Resistance to scratching or cutting. This is hardness in the mineralogical sense.

2. Resistance to indentation, when stressed beyond the elastic limit by a concentrated load applied (*a*) gradually, (*b*) suddenly.

3. Elastic reaction.

1. Sclerometric methods. The mineralogist uses an arbitrary scale of standard minerals, so chosen that each member of the series is scratched by all those minerals above it, and scratches all those below it. Mohs' scale ranges in this way from 1 (talc) to 10 (diamond). A more exact measure of the mineralogical hardness is obtained by scratching with a hardened point (diamond or glass-hard steel) under a fixed load, and either measuring the width of the scratch or determining the loss of weight by abrasion after a given number of passages of the point. The latter method is not employed in metallography. The sclerometer takes many forms, of which that devised by T. Turner¹ is one of the most generally used. A diamond point attached to a lever arm is loaded with a variable load, and is drawn across the polished surface of the specimen, the "hardness number" being the number of grams required to press the point so heavily as to produce a "normal scratch," defined as a scratch which is just visible as a dark line on a bright surface. There is naturally considerable room for error in judging the proper depth of scratch, especially on

¹ *Proc. Birmingham Phil. Soc.*, 1886, 5, 291.

very different materials, and the method is mainly useful in comparing samples of similar materials, such as steels. It gives very concordant results in practised hands.

Martens' form of sclerometer¹ is more generally useful, and has been employed in most scientific investigations of the hardness of alloys. In this case the point, usually loaded with a load of 20 grams, is stationary, whilst the specimen, with its polished surface horizontal, is drawn to and fro by a traversing table. The breadth of the scratch is measured, either by means of a microscope with micrometer eyepiece, or by photographing the scratch under a known magnification, and measuring the photographic image.² The hardness number is

given by the relation $H = \frac{I}{a}$, where a is the breadth of the scratch in mm. When the alloy consists of a conglomerate of two solid phases, it is still possible to obtain useful results as to the hardness, provided that the grain of the mixture is fine. The breadth of the scratch observed is then actually an average value, the microscope showing that the scratch is made up of wide and narrow portions, but a consistent reading is obtained without difficulty if the grain of the alloy is not too coarse. An improved form of Martens' sclerometer, mounted on the stage of a microscope, is described by V. Pöschl.³

In both these forms of sclerometer the motion of the diamond point relatively to the specimen is one of translation, but a movement of rotation may equally well be employed. This is the principle on which Jagggar's microsclerometer, a very delicate instrument designed for mineralogical purposes, is based.⁴ This instrument is really a minute drill, mounted as an attachment to a microscope. The point, a cleavage tetrahedron of diamond, is rotated by hand or by clockwork at constant speed under a constant load. The depth is measured by a small slip of glass, ruled with lines 0.01 mm.

¹ A. Martens, *Mitt. k. techn. Versuchs-Anst.*, 1890, 8, 236.

² N. S. Kurnakoff and S. F. Schemtschuschny, *Zeitsch. anorg. Chem.*, 1908, 60, 1.

³ *Die Härte der festen Körper* (Dresden, 1909).

⁴ T. A. Jagggar, *Amer. J. Sci.*, 1897, [iv.] 4, 399.

apart, and cemented to the lever arm bearing the point. The glass is slightly inclined to the vertical, with its rulings horizontal. The microscope is focussed on one of the lines, and drilling is continued until the next ruling just comes into sharp focus. The drill has then penetrated to a depth of 0.01 mm. The hardness number is the number of revolutions, as recorded on a dial counter, required to drill to that depth under a load of 10 g. This instrument is not only very accurate in its indications, but has the advantage of operating on an exceedingly small area, so that the individual constituents of an alloy may be separately examined if visible in the same micro-section.¹

2. Indentation method. Brinell's test,² which is now the most important hardness test in technical practice, consists in pressing a hardened steel sphere, which will not undergo deformation, on to the surface of the metal to be tested, and measuring the depth of the circular indentation. The hardness number is the pressure per unit area at the centre of that area required to produce the indentation, and within certain limits this is found to be independent of the size of the ball and of the pressure applied. The theory of this form of test has been discussed by Auerbach.³

In the practical application of the test, a hardened steel ball (manufactured for use in bearings), 10 mm. in diameter, is pressed on the surface of the metal under a known load. The simplest form of apparatus is a lever, pivoted at one end and loaded at the other with a known weight, the lever resting on the ball near to the fulcrum. A more convenient appliance is a small hydraulic press, the cylinder of which is filled with oil. Pressure is applied by a pump, and is measured by a separate cylinder, the piston of which is loaded by a lever carrying a

¹ Thus H. C. Boynton, *J. Iron Steel Inst.*, 1906, ii. 287; 1908, ii. 133, examined the constituents of steel with this instrument, obtaining numbers ranging from 460 for pure electrolytic iron to 125,480 for cementite, Fe₃C.

² *Rapp. Congr. intern. Méthodes d'Essai*, Paris, 1900.

³ F. Auerbach, *Ann. Phys.*, 1891, [iii.] 43, 60; 1892, [iii.] 45, 262, 277; 1900, [iv.] 3, 108.

sliding weight.¹ The load being increased to a fixed amount, depending on the nature of the metal or alloy to be examined, the diameter of the circular indentation produced is measured by means of a micrometer. A few results obtained in this way are given in the following table:—

Material.	Maximum pressure on 10 mm. ball.	Diameter of impression.	Hardness number.
	kilog.	mm.	
Copper	500	2·90	74·0
Silver	„	3·25	59·0
Antimony	„	3·35	55·0
Gold	„	3·60	48·0
Zinc.	„	3·65	46·0
Aluminium.	„	4·00	38·0
Tin	„	6·25	14·5
Lead	200	6·30	5·7
Phosphor-bronze	500	2·20	130·0
Bell metal	„	2·25	124·0
Brass	„	3·15	63·0
Phosphor-tin	„	5·45	19·7
Antifriction metals (Pb, Sn, Sb)	„	4-5	37-23

The dependence of Brinell's hardness numbers on the mechanical properties of the metal have been studied, and numerous relationships, of great technical importance, have been discovered.²

3. Elastic reaction method. A somewhat remarkable method, based on the rebound of a hard body from the surface to be tested, is that devised by Shore.³ The instrument, known as the scleroscope, is illustrated in Fig. 83. The specimen *a*, having been squared up and polished, is placed on the anvil *b*, which is provided with levelling screws. The tube *c* has a ground lower edge which is applied closely to the specimen,

¹ E. Preuss, *Baumaterialenkunde*, 1907, 295; A. Wahlberg, *J. Iron Steel Inst.*, 1901, i. 243.

² A. Wahlberg, *J. Iron Steel Inst.*, 1901, i. 243; ii. 234; H. Le Chatelier, *Rev. de Métallurgie*, 1906, 3, 689.

³ A. F. Shore, *American Machinist*, 1907, 30, ii. 747; see also E. Meyer, *Physikal. Zeitsch.*, 1908, 9, 66; R. de Fréminville, *Rev. de Métallurgie*, 1908, 5, 329; J. F. Springer, *Iron Age*, 1908, 82, 555.

the plumb-line *d* being used to secure an exactly vertical adjustment of the tube. A small steel ball, or cylinder with rounded lower end, is raised to the top of the tube by air suction with the rubber ball *e* and then released, falling from a height of exactly 25 cm. on to the specimen. The height of the rebound is measured on the graduated scale of the tube. This can be done very accurately by means of a reading lens, supported on a sliding stand in front of the apparatus. The approximate height of rebound is found by preliminary trial, and the lens is then brought to the required position, after which the exact rebound can be determined with ease. Successive readings give perfectly concordant results. The apparatus is very well made and convenient in use.

A thick mass of hard metal will give under such circumstances a rebound of 95 per cent. of the fall; with a small specimen the rebound is rather of the order of 65 per cent. In studying a series of alloys by this method, all the specimens should be of equal size, and should be well bedded on the anvil. Under these circumstances the results may be considered as strictly comparable. Placing the specimen on a felt or rubber support gives an increased rebound.

Different as these methods of determining hardness are from one another, the relative order of hardness revealed by them when a number of metals and alloys are compared is strikingly similar, if a few exceptional cases be excluded. The nature of these exceptions may be gathered from the behaviour of certain non-metallic substances. A soft but resilient substance like indiarubber, offering an insignificant resistance to the Brinell test and readily cut by a point, gives a higher result with the scleroscope than a mild steel. Different kinds of wood also give results which are inconsistent with their

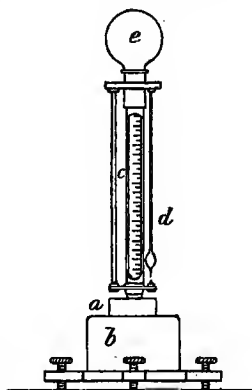

FIG. 83.—Shore's scleroscope.

behaviour towards cutting tools. Amongst metals and alloys, the scleroscope indicates greater hardness in cold-worked specimens than the other methods, that is, the elastic hardness of a cold-worked metal is not the same as its mineralogical hardness, or resistance to abrasion. Annealed and hard-drawn copper differ little in resistance to a diamond point, but behave very differently under the Brinell or scleroscope tests. As regards steels, it would seem that Brinell's method gives results most nearly according with practical experience as to the wearing power of the steel.¹

In the following table, tests on a number of materials have been compared,² and the agreement between the results obtained by different methods is seen to be remarkably good. Cold-worked metals have been excluded. The hardness numbers have been reduced to a uniform scale to facilitate comparison:—

Metal.	Turner's sclerometer.	Shore's scleroscope.	Brinell's ball test.
Lead	1'0	1	1'0
Tin	2'5	3	2'5
Zinc.	6'0	7	7'5
Copper	8'0	8	—
Soft iron	15'0	12	14'5
Mild steel	21'0	22	16-24
Soft cast iron	21-24	24	24'0
Rail steel	24'0	27	26-35
Hard cast iron.	36'0	40	35'0
Hard white iron	72'0	70	75'0
Hardened steel	—	95	93'0

It has long been known that the hardness of a metal bears an intimate relation to its atomic volume, the softest metals being those of greatest atomic volume.³ The rule is an approximate one only, as data as to the hardness of pure elements, determined under strictly comparable conditions, are not forthcoming in sufficient quantity to establish an exact quantitative relation. Consideration of the "internal pressure"

¹ E. Maurer, *Metallurgie*, 1909, 6, 33.

² T. Turner, *J. Iron Steel Inst.*, 1909, i. 426.

³ S. Bottone, *Chem. News*, 1873, 27, 215.

of metals has led to the conclusion that the hardness should be proportional to the quantity $\frac{a}{v^2}$ where v is the atomic volume, and a is van der Waal's constant.¹

The hardness of a metal may be very greatly altered by alloying with another metal. This is, for instance, the object of alloying gold and silver for coinage purposes, the hardness, and therefore the resistance to abrasion in wear, being thereby increased. The way in which the hardness is changed will depend on the nature of the alloy formed, thus—

1. The two metals are mutually insoluble in the solid state, all their alloys being conglomerates of the pure components. The hardness is then nearly a linear function of the composition. It is not exactly so, since a fine-grained eutectic, composed of a soft and a brittle metal, has a hardness in excess of that calculated from its composition, on account of the mutual support offered by the constituents. The values obtained by sclerometric methods, however, approach very closely to those calculated according to the rule of mixtures.

2. The metals form a continuous series of solid solutions. The variation of hardness is expressed by a smooth curve having a pronounced maximum at a composition not far from that corresponding with equal weights of the component metals. A typical example is furnished by the alloys of silver and gold, shown in Fig. 84. The ordinates are sclerometric hardness numbers. An alloy composed of equal weights of gold and silver has a hardness which is practically twice as great as that of either of the pure metals.² Alloys of gold and copper, and of copper and nickel, present similar maxima.

If the two metals form two series of solid solutions separated by a gap, the hardness curve must present a change of slope at each limit of saturation, being rectilinear between them. This is true of the alloys of silver and copper.³

¹ I. Traube, *Zeitsch. anorg. Chem.*, 1903, **34**, 413; 1904, **40**, 377; *Ber.*, 1909, **42**, 1594; C. Benedicks, *Zeitsch. physikal. Chem.*, 1901, **36**, 529.

² Kurnakoff and Schemtschuschny, *loc. cit.*

³ N. S. Kurnakoff, N. A. Pushin, and N. Senkowsky, *Zeitsch. anorg. Chem.*, 1910, **68**, 123.

3. An inter-metallic compound is formed. As a general rule, such compounds are harder than their constituents. A familiar example is the compound Cu_3Sn , which is exceedingly hard and brittle, although its components are soft.

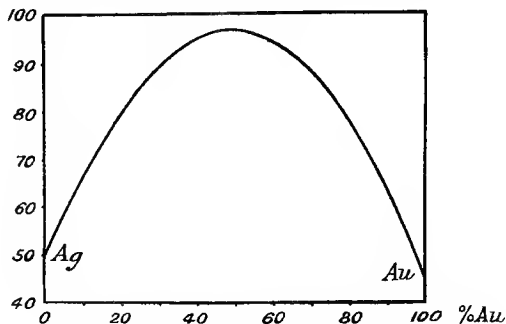

FIG. 84.—Hardness of silver-gold alloys.

A series of alloys containing only a single compound, such as the alloys of magnesium with lead, tin, or silicon, from which solid solutions are absent, has a simple hardness diagram, consisting of two straight lines intersecting at the composition of the compound. The series, in fact, comprises two distinct series of conglomerates, within each of which the variation of hardness is rectilinear. But should solid solutions occur amongst either series, the curve in that region deviates from a straight line. The copper-tin alloys were found by Martens (*loc. cit.*) to present a maximum hardness corresponding with the compound Cu_3Sn , the curve having a sharp peak at this point. A compound which forms solid solutions with both components has its hardness increased by the addition of either metal, and is thus marked by a cusp on the curve directed downwards. The alloys of magnesium and cadmium illustrate this condition.¹

A sharp peak or cusp in the hardness-composition curve of a series of alloys is a sure indication of the existence of a compound at that point. A rounded maximum has not the

¹ G. Urazoff, *Zeitsch. anorg. Chem.*, 1911, 73, 31.

same significance, as it may be due to the formation of a solid solution of increased hardness. A sudden change in the direction of the curve indicates the appearance of a new phase, the nature of which must be determined by other methods.¹

ELECTRICAL CONDUCTIVITY

The specific electrical resistance of an alloy, or its reciprocal, the specific conductivity, has long been recognized as being intimately connected with the internal constitution. The extensive researches of Matthiessen² are, in fact, anterior to the introduction of the thermal method, and have played an important part in the theoretical development of the subject.

According to Drude's theory of metallic conduction,³ the passage of a current through a metal takes place through a transport of electrons. The conductivity depends, then, on two factors, the number of electrons present in unit volume and the frictional resistance to their movement. The first of these is not susceptible of measurement, but has been calculated indirectly from the optical properties,⁴ and also from the thermo-electric properties. The volume-concentration of the electrons is little affected by temperature, as is shown by a comparison of the optical constants of metals at the temperature of liquid air, and at 800°.⁵ Since the electrical conductivity changes very rapidly with the temperature, this variation must be due, on Drude's theory, to variation of the second factor, the frictional resistance. This property, again, cannot be

¹ A good example of the hardness curve of a complex system is given by the alloys of magnesium and silver; W. J. Smirnoff and N. S. Kurnakoff, *Zeitsch. anorg. Chem.*, 1911, 72, 31.

² A. Matthiessen, *Phil. Trans.*, 1858, 148, 383; 1860, 150, 161; *Phil. Mag.*, 1861, [iv.] 21, 107; [iv.] 22, 195; A. Matthiessen and M. Holzmann, *Phil. Trans.*, 1860, 150, 85; A. Matthiessen and C. Vogt, *ibid.*, 1864, 154, 167; *Phil. Mag.*, 1862, [iv.] 23, 171.

³ P. Drude, *Ann. Physik.*, 1900, [iv.] 1, 566; 3, 369; 1902, [iv.] 7, 687.

⁴ P. Drude, *Ann. Physik.*, 1904, [iv.] 14, 936.

⁵ R. Schenck, *Physikalische Chemie der Metalle*, Halle, 1909.

measured directly. It bears an obvious relation to the hardness, and it is not surprising to find, therefore, that hardness and electrical conductivity exhibit a close parallelism in series of alloys.

Electrolytic conduction does not occur in metallic alloys, and there is no continuous transition from the one mode of conduction to the other.

The methods of measuring the conductivity of a metal or alloy belong rather to physics than to metallography. The principal difficulty which confronts the metallographist who wishes to examine the conductivity of a series of alloys is that of obtaining suitably homogeneous specimens for measurement. Alloys which it is possible to draw into wire are examined with ease, and there is also little difficulty in forging small rods of malleable alloys, but a large proportion of specimens are necessarily examined in the cast state, and in a great number of cases the brittleness is such that it is not possible to reduce the cast specimens to accurate form by cutting or filing. Hard metals, if not too brittle, may be ground to shape on a wet emery wheel with light pressure. Very brittle alloys will not bear this treatment, and the experimenter must be content with cast rods. When the melting-point is not too high, smooth rods of uniform diameter may be obtained by the device of drawing the molten metal with the aid of a pump into previously heated glass tubes, coated internally with lamp-black. The glass is afterwards carefully broken away from the rod.¹ Cast specimens should always be examined microscopically for homogeneity, since gas-cavities lead to errors of the same nature as in determinations of density.

The cause of the increased resistance of alloys as compared with that of their component metals has been much discussed. It has been suggested by Lord Rayleigh² and also by Liebenow,³ that the Peltier effects at the numerous boundaries between the structural components give rise to thermo-electric currents, which have the same effect as an increased resistance. This hypothesis appears to explain the facts fairly well so far as

¹ N. J. Stepanoff, *Zeitsch. anorg. Chem.*, 1908, 60, 209.

² *Nature*, 1896, 54, 154; *Collected Papers*, iv. 232.

³ C. Liebenow, *Zeitsch. Elektrochem.*, 1897, 4, 201.

concerns alloys which are mechanically heterogeneous, but its application to solid solutions presents difficulties. Theoretically, the Peltier effects may be supposed to occur even when the state of subdivision of the components is a molecular one, as in a solid solution. But the remarkable form of the typical U-shaped curve is hardly to be explained in this way, and the hypothesis must be admitted to fail in this important class of cases.¹

An attempt has been made to test Rayleigh's suggestion experimentally.² Assuming the resistance to be due to Peltier effects, the resistance offered to the passage of an alternating current should be distinctly less than that offered to a direct current, as the time allowed during each alternation would probably be insufficient to allow the temperature to become equalized, and the back E.M.F. would not be set up. In a series of experiments with German silver, platinum-iridium, platinum-silver, and similar alloys, it was found that no false resistance could be detected in this way, even when a rapidly alternating current from an induction coil was used. All the alloys examined consisted of solid solutions, and it does not appear that alloys composed of conglomerates have been tested by this method. The evidence is not conclusive, but so far experimental evidence has not been obtained in favour of Rayleigh's hypothesis, and it may perhaps prove that the application of Drude's views on metallic conduction may bring more light into the question.

When it is desired to express the dependence of the electrical properties on the composition of alloys, either the specific resistance or its reciprocal, the specific conductivity, may be selected as the magnitude for comparison. The conductivity is usually to be preferred, as giving the simpler relationships.

The specific conductivity of conglomerates is very nearly proportional to their volume composition. The conductivity-concentration curve of alloys forming a simple eutectiferous

¹ R. Schenck, *Metallurgie*, 1907, 4, 161; *Physikal. Zeitsch.*, 1907, 8, 239; R. Guertler, *Zeitsch. anorg. Chem.*, 1907, 54, 58.

² R. S. Willows, *Phil. Mag.*, 1907, [vi.] 12, 604.

series, that is to say, closely approximates to a straight line, if the concentration be expressed, as was done by Matthiessen, in percentages by volume. The reason for this will be seen if we consider that the constituents of a mechanical mixture conduct independently, so that we may imagine them separated, drawn into wires of equal length, and placed side by side in a bundle. The conductivity of the whole bundle is then the sum of the conductivities of its constituent wires, and as the conductivity of each wire is proportional to its cross-section, and the wires are of equal length, it is the *volume* of each constituent which must be taken into account in the linear relation. Peltier effects, the production of back E.M.F. owing to heating at the contact of crystals of different kinds, are here neglected, but they may become appreciable, giving rise to deviations from the linear relation, in the sense of giving a conductivity lower than that calculated from the conductivity of the component metals and the volume-composition. The small deviations observed in alloys of lead and cadmium, and of zinc and cadmium, are of the order required by this thermo-chemical explanation.

A very different condition presents itself in those alloys which consist of solid solutions. The conductivity of a pure metal is lowered to a remarkable degree by the addition of small quantities of a second metal which it is capable of retaining in solid solution. In the graphical representation the conductivity curve falls very steeply for small percentages of the second metal, the slope then becoming less steep. In similar manner the other end of the curve shows a steep fall, the intermediate portion being gently curved. The entire conductivity curve has therefore a characteristic **U** shape, being continuous throughout. The curve for the alloys of gold and silver, determined by Matthiessen, is typical of this condition (Fig. 85). Alloys containing nearly equal volumes of the two metals have a conductivity which is only about one-fifth of that of gold, the less conducting of the two components.¹ The

¹ The determinations of V. Strouhal and C. Barus, *Abh. k. böhm. Ges. Wiss.*, 1884, [v.] 12, No. 14, agree with those of Matthiessen. A large number of curves, recalculated to a uniform scale, are collected in the

case of the alloys of copper and nickel is perhaps even more striking, on account of the very unequal conducting powers of the two metals. Although the conductivity of copper is about seven times that of nickel, the addition of copper to nickel produces a rapid diminution of the conductivity, and the curve has the typical **U** form, the arms being of very unequal length.

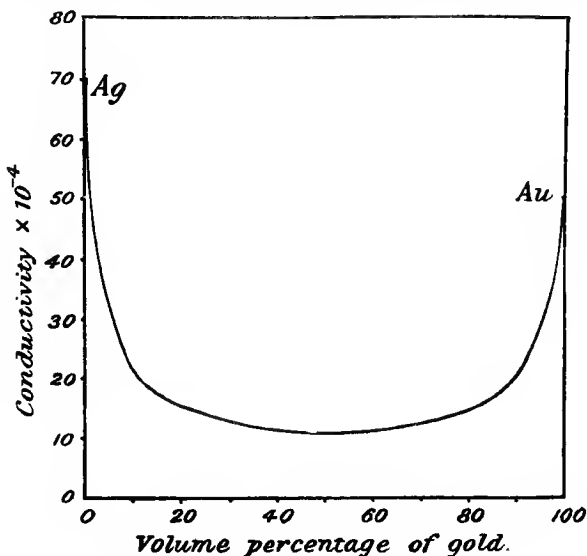

FIG. 85.—Conductivity of silver-gold alloys.

This property of solid solutions is utilized in the construction of electrical resistances, constantan, for instance, being an alloy of 60 per cent. copper and 40 per cent. nickel. The number of complete curves of this type which have been determined is small, but the numerous partial determinations which exist leave no doubt that the **U** form is characteristic of all alloys forming an unbroken series of solid solutions, whether the freezing-point curve has a minimum, as in the

memoir by W. Guertler, *Zeitsch. anorg. Chem.*, 1906, 51, 397, from which some of the data in this section have been taken.

alloys of copper with gold or manganese, or is of the simpler type exhibited by the gold-silver series.

The behaviour of alloys in which two series of solid solutions are separated by a gap may now be inferred. Within the limits of formation of the solid solutions, the depression of conductivity takes place, as in alloys of gold and silver, very rapidly, but between the limits of the saturated solutions the variation is linear. The entire curve therefore consists of two rapidly falling branches, connected by a straight line. If this

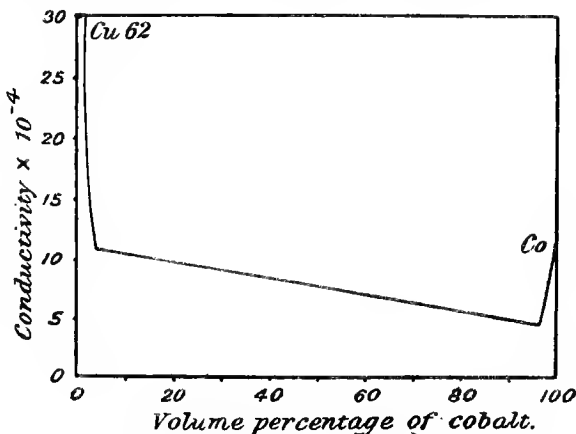

FIG. 86.—Conductivity of copper-cobalt alloys.

line happens to be nearly horizontal, it may be possible to mistake the entire curve for the U form of completely isomorphous metals. Exact measurements with a sufficient number of alloys will, however, reveal the change of inclination at the junction of the branches. Curves of this kind are given by the alloys of copper and silver (Matthiessen) and of copper and cobalt,¹ the diagram of the latter being reproduced in Fig. 86.

Inter-metallic compounds conduct like pure metals, although their conductivity is always less than that of the better conducting component, and in all instances hitherto observed falls

¹ G. Reichardt, *Ann. Physik.*, 1901, [iv.] 6, 832.

below that calculated from the conductivity of the components by the rule of mixtures. What has been said as to the influence of compounds on the curve of hardness applies to a considerable extent to the conductivity also. The presence of a sharp cusp in the curve is unmistakable evidence of the existence of a compound, but the converse does not hold good. Should a single compound exist in the series and no solid

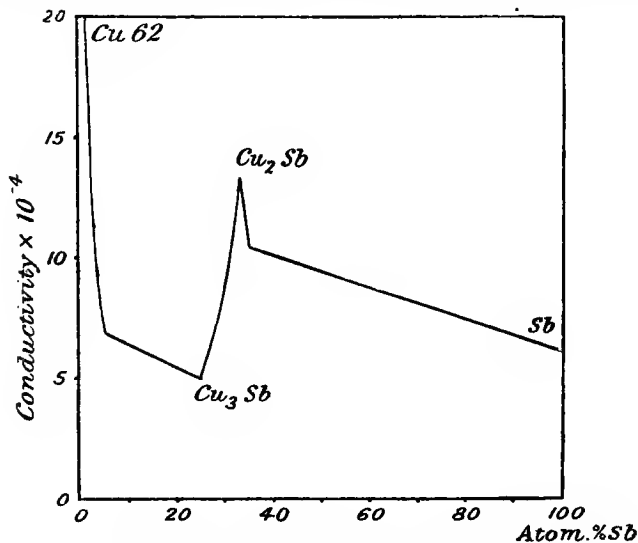

FIG. 87.—Conductivity of copper-antimony alloys.

solutions be formed, the curve consists of two intersecting straight lines. A sharp cusp is most likely to occur if the compound forms solid solutions with both components, as the addition of either component, in accordance with the general behaviour of solid solutions, then depresses the conductivity very rapidly. The alloys of copper and antimony furnish a typical example.¹ The curve of conductivity (Fig. 87) has a

¹ G. Kamensky, *Phil. Mag.*, 1884, [v.] 17, 270. An equilibrium diagram, not, however, quite complete, has been determined by A. Baikoff, *Bull. Soc. d'Encouragement*, 1903, 104, 626.

sharp cusp, corresponding with the compound Cu_2Sb , which forms solid solutions with copper, whilst the second compound Cu_3Sb is only indicated by an abrupt change of conductivity, in this case presenting itself as a minimum.

To sum up, although it is not in general possible to predict the form of the conductivity curve of a series of alloys whose structure is known, yet the observation of the conductivity gives some very definite information as to the structure of the alloys, in accordance with the following rules:—

1. A linear relation between conductivity and concentration indicates that the alloys are conglomerates, and that the mutual solubility of the two metals in the solid state does not exceed a very small amount, probably within 0.1 per cent.

2. A linear relation over the greater part of the range of composition, the diagram being completed by two steeply rising curves at the ends, indicates a limited mutual solubility in the solid state, the extent of which may be determined from the position of the points of intersection. If one metal dissolves the other to a small extent, but not conversely, the rapid fall only takes place at one end of the diagram, giving the L-shaped curve observed by Matthiessen in a number of instances, of which the alloys of tin and bismuth may be specially mentioned.

3. A smooth, U-shaped curve indicates the formation of a continuous series of solid solutions. Careful determinations are necessary to ascertain whether the curve is smooth throughout; with an insufficient number of measurements a short rectilinear branch, indicating a gap in the solid solutions, may be overlooked.

4. A sharp cusp, with the point directed upwards, indicates the presence of a compound capable of forming solid solutions.

5. Abrupt changes of direction in the curve indicate the appearance of a new solid phase at that point, but investigation by other means is required to determine the nature of the phase.

When it is desired to study the influence of minute additions of one metal to another on its conductivity, there are

advantages in plotting the specific resistance, instead of its reciprocal, against the concentration by weight of the second metal. Since the conductivity is most greatly modified by additions when the latter enter into solid solution, it is this case which presents the greatest practical interest. For the purposes of the electrical manufacturer, copper of the highest attainable conductivity is required, and the depreciation of its value by the presence of traces of impurities calls for chemical and physical investigation. It has been shown that the curve representing this depreciation falls very steeply at first. The actual form is that of a hyperbola for at least the initial portion of its course, and it follows that the curve of specific resistance, which = $r \div$ specific conductivity, is very nearly rectilinear.

On comparing the influence of different elements on the specific resistance of iron, Benedicks¹ found that the increase of resistance is proportional to the atomic percentage of the added element, provided that the latter is present in solid solution. Carbon is held in solid solution only in hardened steels, which are therefore taken for comparison.² In slowly cooled steels the carbon is in the form of cementite, Fe_3C , mechanically mixed with metallic iron, and therefore only a small increase of resistance is produced by the presence of small amounts of carbon in this state. It appears possible, however, that the iron in slowly cooled steels retains up to 0.27 per cent. of carbon in solid solution, and within that limit the linear atomic increase of resistance holds good. Benedicks has adduced experimental evidence in favour of the existence of such a solution in soft steels.³

For elements in solution in iron at the ordinary temperature the relation—

$$W = 7.6 + 26.8 \Sigma C$$

gives the resistance in microhms per c.c., ΣC being the total dissolved carbon, + the sum of all the other dissolved elements,

¹ *Zeitsch. physikal. Chem.*, 1902, **40**, 545.

² Numerous data are found in the exhaustive researches of W. Barrett, W. Brown, and R. A. Hadfield, *Trans. Roy. Dubl. Soc.*, 1902, **8**, 1; *Proc. Roy. Soc.*, 1902, **69**, 480; *J. Inst. Elect. Eng.*, 1902, **31**, 674.

³ *Thèse pour le Doctorat.*, Upsala.

calculated to their "carbon-value" by the rule of atomic equivalence given above. The table below contains the data from a number of steels examined by Benedicks.

The samples consisted of Swedish steel of high quality. Those marked q were hardened by quenching from about 800°, except the last two, which were quenched from a yellow heat. The measurements were made at 16°, and the resistances are expressed in microhms per c.c. Calculations from the data obtained by Barrett, Brown, and Hadfield,¹ and Hopkinson,² show that aluminium, chromium, and tungsten also obey the same rule.

No.	Carbide, C	Dissolved elements.				Resistance.		
		Hardening C.	C-value of Si.	C-value of Mn.	ΣC.	Obs.	Calc.	Diff.
1	—	0·08	0·013	0·028	0·121	10·5	10·8	-0·3
1 q	—	0·08	0·013	0·028	0·121	10·9	10·8	+0·1
8	1·43	0·27	0·034	0·063	0·367	17·7	17·4	+0·3
7	1·23	0·27	0·051	0·063	0·384	17·9	17·9	0·0
4	0·63	0·27	0·118	0·089	0·477	20·2	20·4	-0·2
5	0·93	0·27	0·127	0·096	0·493	20·9	20·8	+0·1
6	1·08	0·27	0·110	0·118	0·498	21·6	21·0	+0·6
2	0·18	0·27	0·274	0·076	0·620	23·9	24·2	-0·3
3	0·28	0·27	0·363	0·096	0·729	27·6	27·2	+0·4
2 q	—	0·45	0·274	0·076	0·800	29·0	29·0	0·0
3 q	—	0·55	0·363	0·096	1·009	34·4	34·6	-0·2
4 q	—	0·90	0·118	0·089	1·107	36·9	37·3	-0·4
5 q	[0·14?]	1·20	0·127	0·096	1·423	[42·1]	45·7	[-3·6]
6 q	—	1·35	0·110	0·118	1·578	49·6	49·9	-0·3
7 q	—	1·50	0·051	0·063	1·614	50·6	50·8	-0·2

The electrical conductivity of metals and alloys varies in a marked degree with the temperature, and a general proportionality between the conductivity and its temperature-coefficient was noticed by Matthiessen. This aspect has been more fully studied by Guertler.³ The conductivity decreases with rising temperature, its coefficient is therefore negative. The conductivity of pure metals continues to increase as the temperature

¹ *Loc. cit.*

² J. Hopkinson, *Phil. Trans.*, 1885, 176, 463.

³ *Zeitsch. anorg. Chem.*, 1907, 51, 58.

falls, and the course of the temperature curve has been taken to indicate¹ that at or near the absolute zero the conductivity would become infinite. If the metal contains a second metal in solution, its conductivity increases with falling temperature until a finite value is reached, which remains constant at still lower temperatures.² This may be expressed by saying that the additional resistance due to the presence of the added metal is independent of temperature, and this rule holds good of solid solutions at all temperatures.

For metallographic purposes it is convenient to express temperature-coefficient as the percentage decrease of conductivity between 0° and 100°, so that

$$P = \frac{\kappa_0 - \kappa_{100}}{\kappa_0} \cdot 100$$

For pure metals P has the value 27-31, and the same number is found for alloys which consist solely of conglomerates of their components. If solid solutions are formed, the value of P falls much lower. The curve representing the change of the temperature-coefficient with concentration has, in fact, a very similar form to the conductivity-concentration curve, with a deep minimum in the middle of a series of solid solutions. On this fact depends the possibility of obtaining alloys, the conductivity of which is within certain limits independent of the temperature. Thus constantan, an alloy containing 60 per cent. copper and 40 per cent. nickel, has a zero temperature-coefficient at ordinary temperatures, and the same is practically true of the alloy containing 80 per cent. copper and 20 per cent. manganese, and of platinoid (60 per cent. Cu, 24 per cent. Zn, 14 per cent. Ni, and 1-2 per cent. W). Guertler has used three-dimensional diagrams to express the relations of the conductivity, temperature, and concentration of alloys.

The value of P for inter-metallic compounds is somewhat

¹ J. A. Fleming and J. Dewar, *Phil. Mag.*, 1892, [v.] 34, 326; 1893, [v.] 36, 271.

² A summary of the facts relating to the conductivity of metals and alloys at low temperatures is given by J. Clay, *Jahrb. Radioakt. Elektronik*, 1911, 8, 383.

smaller than for pure metals, being 26·8 for Ag_3Sn , 22 for CuSn , and 22·4 for AuSn_4 , so that their inversion temperature probably lies above that of the pure metals. The presence of compounds affects the temperature-coefficient diagram in the same way as the conductivity diagram. When the practical difficulties are such that it is not possible to obtain a complete series of alloys in a sufficiently homogeneous and non-porous state for conductivity measurements, P may be advantageously determined by observations of the conductivity at 0° and 100° , and the same conclusions as to the constitution of the alloys may be drawn as from the conductivity curve.

An abrupt change in the conductivity occurs at the melting-point. There is a remarkable similarity between the conductivity curves of liquid and solid alloys. Thus the conductivity of molten alloys of lead and tin is proportional to their composition, whilst alloys of copper and nickel give a U-shaped curve. Inter-metallic compounds which are sufficiently stable to persist in the molten state cause the appearance of a peak or kink in the curve. Examples of this are the compounds Hg_2Na , Hg_2K , and Cu_3Sb .¹

Lastly, mention may be made of the ratio of thermal to electrical conductivity. Whilst the thermal conductivity, λ , has been little employed as a means of studying alloys, its ratio to the electrical conductivity, $\frac{\lambda}{\kappa}$, has some value for this purpose.

The values of $\frac{\lambda}{\kappa}$ for pure metals at a given temperature are nearly equal, and increase proportionally to the absolute temperature. The values of $\left(\frac{\lambda}{\kappa}\right)_{100^\circ} : \left(\frac{\lambda}{\kappa}\right)_{0^\circ}$ vary, for different metals, only between 1·12 and 1·35.²

In alloys, $\frac{\lambda}{\kappa}$ has a higher value than in pure metals if solid

¹ P. Müller, *Metallurgie*, 1910, 7, 730, 755; K. Bornemann and G. von Rauschenplat, *ibid.*, 1912, 9, 473, 505.

² G. Wiedemann and R. Franz, *Ann. Physik.*, 1853, [ii.] 89, 497; W. Jaeger and H. Diesselhorst, *Abh. phys.-techn. Reichs-Anst.*, 1900, 3, 269; E. Grüneisen, *Ann. Physik.*, 1900, [iv.] 3, 43.

solutions are formed, that is, the formation of the solution depresses the thermal relatively less than the electrical conductivity, $\frac{\lambda}{\kappa}$ being, for instance, 665 for copper, 699 for nickel, and 1106 for constantan. If solid solutions are not formed, $\frac{\lambda}{\kappa}$ has the same value as for pure metals.¹ The reverse action, a diminution of the ratio, has been observed to occur in the alloys of copper with arsenic and phosphorus.² It remains to be seen whether this influence of non-metals is a general one.³

The practical methods of determination of λ are fully described in the memoir of Jaeger and Diesselhorst (*loc. cit.*).

THERMO-ELECTRIC POWER

Alloys, like pure metals, develop a thermo-electromotive force when two dissimilar specimens are connected, one junction being heated or cooled to a different temperature from that at which the other is maintained. In making the experiments the two specimens are only in contact with one another at a single junction, their other ends being connected with copper wires leading to the galvanometer or potentiometer employed to measure the electromotive force. When alloys are under investigation, it is usual to employ a junction consisting of the alloy and of one of its component metals, although another metal, such as copper or platinum, may also be used as a standard. The specimens are most conveniently taken in the form of rods or wires, but this is not always practicable with brittle alloys. Experiments on crystals of bismuth⁴ indicate that the thermo-electric power varies with the orientation, so that the results obtained with cast or drawn rods or wires are average values. The specimens should be thoroughly annealed,

¹ F. A. Schulze, *Ann. Physik.*, 1902, [iv.] 9, 555.

² A. Rietzsch, *ibid.*, 403.

³ See also E. van Aubel and R. Paillet, *J. Physique*, 1895, [iii.] 4, 522.

⁴ L. Perrot, *Arch. Sci. phys. nat.*, 1898, [iv.] 6, 105, 229; 1899, [iv.] 7, 149.

as mechanical work has a great influence on the thermo-electric properties.

Many investigators have found that alloys do not necessarily occupy a position in the thermo-electric series intermediate between those of the component metals. The data available are insufficient to determine the cause of the variations observed, but it is probable that the formation of inter-metallic compounds is an important factor. For example, whilst the amalgams of Zn, Sn, Pb, Cd, and Cu fall between mercury and the corresponding metal, the amalgams of Bi, Tl, Mg, and Na deviate from this rule. The former series contains metals which do not combine with mercury, whilst the latter series consists of metals which form compounds.

The E.M.F. developed in a thermo electric circuit varies greatly with the temperature, and for most pairs of metals or alloys becomes zero at a certain temperature, the neutral or inversion temperature, after passing which it changes in sign. For a large number of pairs, the relation is expressed by the formula—

$$E = (t_2 - t_1) [a + c(t_2 + t_1)]^1$$

in which t_1 and t_2 are the temperatures of the junctions, and a and c are constants. The inversion temperature is given by the formula—

$$\tau = -\frac{a}{2c}$$

The validity of Avenarius' equation has been tested for a large number of metals and alloys,² and more complicated expressions have been introduced to cover the observed deviations. Experiments in which the junction is kept at the low temperature of liquid air have been made,³ and further deviations from the simple relation have been found.

¹ R. Avenarius, *Ann. Physik.*, 1863, **119**, 406; 1864, **122**, 193; 1873, **149**, 372.

² W. Jaeger and H. Diesselhorst, *Abh. phys. techn. Reichs-Anst.*, 1900, **3**, 269; L. Holborn and A. Day, *Sitzungsber. k. Akad. Wiss. Berlin*, 1899, 691.

³ J. Dewar and J. A. Fleming, *Phil. Mag.*, 1895, [v.] **40**, 95; De Metz, *Compt. rend.*, 1904, **139**, 447.

The variation of the thermo-electric power with the composition of alloys follows very similar laws to the conductivity. Inter-metallic compounds are commonly marked by a peak on the curve, and the indications are often even more distinct than those of the conductivity or its temperature-coefficient. Excellent examples are furnished by the alloys of magnesium with aluminium and with silver,¹ and of tellurium with bismuth and with antimony.²

The measurement of the thermo-electric force when coupled with an inactive metal, such as platinum, may also be employed as a means of locating transformations in an alloy, a critical point being indicated by an abrupt discontinuity in the E.M.F. curve. This method has often been applied to steels, and has yielded results confirmatory of those obtained by other methods. The use of thermo-electric measurements in detecting the effect of mechanical changes on metals and alloys will be referred to later (Chapter XVI.).

MAGNETIC PROPERTIES

Magnetic properties are exhibited by the majority of metals and alloys in so slight a degree that their measurement is without metallographic interest. It has been shown³ that the magnetic susceptibility of the elements is a periodic function of the atomic weight, but it is only in a few groups that the value exceeds a very minute amount. The group Fe, Ni, Co, of the so-called ferromagnetic metals, is distinguished from all others by the highly magnetic character of its members, and until recently the interest of the metallurgist in magnetic properties was confined to these metals and to certain of their alloys. The discovery in 1903 of a strongly magnetic alloy

¹ W. Broniewski, *Compt. rend.*, 1910, 150, 1754; 1911, 152, 85.

² W. Haken, *Ann. Physik.*, 1910, [iv.] 32, 291.

³ J. Koenigsberger, *Ann. Physik.*, 1898, [iii.] 66, 698; Stefan Meyer, *ibid.*, 1899, [iii.] 68, 324; *Monatsh.*, 1899, 20, 369, 797; *Ber.*, 1900, 33, 1918; O. Liebknecht and A. P. Wills, *Ann. Physik.*, 1900, [iv.] 1, 178; H. du Bois and O. Liebknecht, *Ber.*, 1899, 32, 3344; H. du Bois, *Rapp. Congr. intern. Phys.*, Paris, 1900, ii. 460.

of copper, manganese, and aluminium,¹ has given a new stimulus to the study of the magnetic properties of alloys, since it is now clear that metals, only feebly magnetic in themselves, may under certain conditions form magnetic compounds with one another.

The change of magnetic properties with temperature has also great metallographic importance. The change is not continuous, but takes place abruptly at certain critical temperatures, and it becomes of interest to correlate these critical points with the discontinuities in the thermal, microscopical, and other properties. Much research has been directed, in particular, to the changes which occur at the low temperature of liquid air.

The phenomena of magnetism are so complex that it is impossible to give in this place more than the briefest outline of the magnetic study of alloys, and reference must be made to text-books on physics for details as to the methods employed and the results obtained.

For the purpose of metallographic investigations, the specimens are most conveniently examined with the aid of a

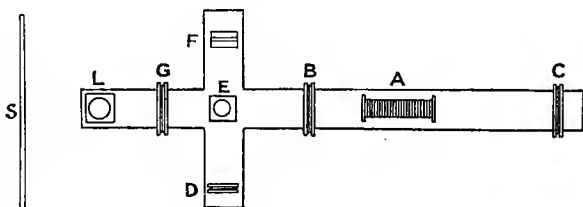

FIG. 88.—Gray and Ross's magnetometer.

magnetometer, the deflections of a minute suspended magnet when placed near to the specimen being observed. Such magnetometers take many forms. Since the metallographist may desire to make observations on the same specimen at many different temperatures, all other conditions remaining identical throughout, this requirement must be kept in mind in the design of an instrument. Gray and Ross's magnetometer is simple, and lends itself readily to accurate investigations of

¹ F. Heusler, *Verh. deut. physikal. Ges.*, 1903, 219; F. Heusler, W. Stark, and E. Haupt, *ibid.*, 222.

this kind.¹ This instrument is shown in plan in Fig. 88. The heavy cross-shaped base is of mahogany, with a channel in which the blocks supporting the coils, etc., slide and are clamped by means of friction clamps. The solenoid A is of insulated wire wound on a thin brass water-jacket, which keeps the wire cool even when the heating furnace is introduced. The magnetometer E consists of a small magnet, 8 mm. in length, with a concave mirror attached, suspended by a quartz fibre. The incandescent lamp L has a fine cross-wire, the image of which is reflected by the magnetometer mirror on to the scale S. The coil B, which is wound in sections, is intended to compensate for the effect of the current in the solenoid. As a small displacement of B has a considerable effect on the deflection of the needle, and it is difficult to secure a sufficiently exact adjustment, a second compensating coil, C, is placed at a greater distance, and on the opposite side of the solenoid. Since C contributes only a small fraction of the balance, it is easily adjusted to the proper position. The small coil D compensates for any deviation from the coaxial arrangement of the other parts of the apparatus. Lastly, a coil, G, connected with a cell and reversing key, is added as a means of bringing the needle rapidly to rest.

The instrument is placed with its principal axis exactly in an east-and-west direction. The coils are adjusted until no deflection of the needle is produced when the current in the solenoid is reversed, even when a small permanent magnet is placed on the transverse arm, as at F.

The width of the water-jacket of the solenoid is sufficient to admit the electric furnace, a porcelain tube wound with platinum wire packed in kaolin, and enclosed in an outer tube of Jena glass. For experiments at low temperatures, a glass tube or a Dewar vessel containing liquid air is used. The specimens are used in the form of rods, 20 cm. in length and 1 cm. or less in diameter.

The field strength H is calculated from the strength of the magnetizing current in ampères C , being equal, with a very small correction, to $0.4\pi nC$, where n is the number of turns in

¹ J. G. Gray and A. D. Ross, *Proc. Roy. Soc. Edin.*, 1909, 29, 182.

the solenoid per unit length. Field strengths up to 400 units may be obtained without difficulty with the above apparatus. The magnetic moment I is measured by the deflection of the magnetometer needle. The ratio I/H gives the susceptibility κ .

Many other forms of apparatus are employed in magnetic investigations. Thus curves of magnetization and hysteresis measurements are commonly made with annular specimens of metal, on which coils for magnetization and for measurement of the magnetic induction are wound.¹ The induction is measured by a ballistic galvanometer. For rapid determinations of the hysteresis for technical purposes, instruments are used in which the specimen is rapidly rotated between the poles of a curved suspended permanent magnet, the hysteresis being measured by the torque produced, tending to rotate the magnet.² The magnetic balance, a modification of the older instrument of Hughes, has also found technical application in various forms.³

The magnetometric method is, however, the simplest in character, and the most convenient for the scientific investigation of alloys.

In the study of alloys, the *susceptibility*, κ , or the ratio of the magnetic moment, I , per c.c. to the strength of field, H , is the most convenient magnitude to employ. The permeability, $\mu = 1 + 4\pi\kappa$, is much used in considering metals and alloys from the point of view of their technical application.

When pure soft iron is magnetized by an external field of gradually increasing strength, the value of κ is at first almost constant so long as H does not exceed 0.05 C.G.S. unit.⁴ For very pure iron, $\kappa =$ about 30,⁵ but the value always falls below this for ordinary samples. As H rises to 10, the susceptibility increases rapidly to a maximum of about 400. For higher

¹ J. A. Ewing and H. G. Klaassen, *Phil. Trans.*, 1893, 184, A, 985; Mme. M. S. Curie, *Bull. Soc. d'Encouragement*, 1898, 36; *Étude des Alliages*, 1901, 159.

² J. A. Ewing, *ibid.*

³ J. A. Ewing, *J. Inst. Elect. Eng.*, 1898, 27, 526; de Kryloff, *Rev. de Métallurgie*, 1905, 2, 425.

⁴ For the dimensions of the units employed, reference should be made to works on physics.

⁵ H. du Bois, *Rapp. Congr. intern. Phys.*, 1901, ii. 460.

values of H the susceptibility decreases, that is, a much greater increase of H is necessary to produce a given increase in I than in the earlier stages. After the magnetization has reached two-thirds of its maximum value, it increases only very slowly, the susceptibility therefore diminishing also, to become zero when $H = \infty$. The strength of field may be carried to 20,000 units without great difficulty, and a value of $H = 51,600$ has been attained.¹

When the maximum value of I has been reached, the metal is said to be magnetized to saturation. This point lies in the case of iron near $I = 1850$, but is lower in the case of other magnetic substances, being 580 or less for nickel and 1370 for cobalt.

The magnetic properties of metals and alloys are influenced in a marked degree by change of temperature. A complete representation of the magnetic behaviour of a substance under conditions of equilibrium is therefore only possible by means of a three-dimensional model, in which I is shown as a function of the strength of field H and the temperature θ . In practice, we may use plane sections of two kinds through the model, one series representing the variation of I with H at constant temperature, and the other the dependence of I on θ under the influence of a constant field.

Considering first the case of iron, the effect of heating above the ordinary temperature is at first to increase the susceptibility, and at the same time to diminish the value of I at which the susceptibility is a maximum. The increase of κ just before reaching 760° is extremely rapid, but at this point the magnetization falls rapidly. Although it is usual to describe this temperature as a critical point, it is more correct to speak of a transformation range, as the change from a highly magnetic to a practically non-magnetic modification of iron is not instantaneous, but continues over a definite range of temperature. It corresponds with the $\alpha \rightarrow \beta$ change, which appears also on the expansion curves as a gradual transformation, although it is more distinctly indicated at 760° on the thermal curves. The reappearance of magnetic properties on cooling from a high temperature takes place over the same

¹ E. T. Jones, *Ann. Physik.*, 1896, [iii.] 57, 273.

temperature range. At higher temperatures, further variations in the magnetic properties of iron have been observed,¹ including a sudden and very large increase in the susceptibility at 1280° ; but it is at present impossible to correlate these changes with any known discontinuities in the other properties of iron, and until the experiments have been repeated with all the precautions necessary to avoid the disturbing influence of dissolved gases, etc., the results must be accepted with reserve. Very numerous observations of the magnetic behaviour of iron at low temperatures, down to -186° , have been made, the results indicating that the saturation capacity increases with diminishing temperature. Different specimens of iron and steel, however, behave very differently, as regards the changes of susceptibility at low temperatures.² Curie's law, which holds good for paramagnetic substances, that the susceptibility is proportional to the absolute temperature, is apparently not fulfilled for the strongly ferromagnetic metals.

The magnetic observations forming part of a metallographic investigation have been confined, in the majority of cases, to the determination of the temperatures at which marked magnetic properties disappear on heating and reappear on cooling. The magnetic measurements are often merely qualitative, the point being noted at which a poised magnetized needle is attracted. If we are dealing with alloys of iron, the temperature of transformation is the same throughout all alloys of the series in which iron is present as a separate phase. Alloys containing iron in a solid solution exhibit a depression or elevation of the transformation point, according to the concentration of the solid solution. The same statement holds good of cobalt and nickel, the transformation temperatures of which are 1159° and 320° respectively.

A simple instance of the behaviour of solid solutions of magnetic metals is afforded by the alloys of nickel and cobalt,³ which form an isomorphous series. The complete diagram

¹ P. Curie, *Ann. Chim. Phys.*, 1895, [vii.] 5, 289; see also D. K. Morris, *Phil. Mag.*, 1897, [v.] 44, 213.

² J. A. Fleming and J. Dewar, *Proc. Roy. Soc.*, 1896, 60, 81.

³ W. Guertler and G. Tammann, *Zeitsch. anorg. Chem.*, 1904, 42, 353.

has the form shown in Fig. 24, the magnetic transformation being represented by a continuous pair of curves between 320° and 1159° , the space between which represents the interval over which the transformation takes place. There is thus complete isomorphism between β -nickel and β -cobalt, and also between α -nickel and α -cobalt.

The alloys of iron and manganese exhibit a different behaviour. The magnetic transformation temperature of iron is rapidly lowered by small additions of manganese, and the diagram, so far as it has been investigated, resembles Fig. 25. These alloys may be obtained in a partly magnetic state by quenching from above the transformation curve.¹ Aluminium also depresses the transformation temperature of iron.

As a type of alloys in which the magnetic metal persists throughout as an independent phase, we may take the series gold-nickel, the freezing-point curve of which has the simple V form, solid solutions being absent. The transformation temperature of nickel remains constant throughout the series, and the boundary separating the regions of stability of α and β nickel therefore runs horizontally across the diagram.²

Very remarkable conditions are presented by the alloys of iron and nickel. The freezing-point curve indicates that solid solutions are formed, as well as a compound, the formula of which is provisionally written as Fe_2Ni .³ The magnetic transformation temperature of iron is lowered by the addition of nickel, and that of nickel raised by the addition of iron, but the curve connecting these two points, instead of being continuous, rises to a maximum at 600° and 70 per cent. Ni, with an intermediate minimum or eutectoid point below 0° at 25 per cent. Ni.⁴ On the iron side of this point, that is to say, in alloys containing less than 25 per cent. Ni, there are two trans-

¹ R. A. Hadfield, *Proc. Inst. Civ. Eng.*, 1888, 93, iii. 1; M. S. Curie, *Étude des Alliages*, 177. For the freezing-point curve, see M. Levin and G. Tammann, *Zeitsch. anorg. Chem.*, 1905, 47, 136.

² M. Levin, *ibid.*, 1905, 45, 238.

³ W. Guertler and G. Tammann, *ibid.*, 1905, 45, 205; R. Ruer, *Metallurgie*, 1909, 6, 679.

⁴ F. Osmond, *Compt. rend.*, 1894, 118, 532; 1899, 128, 304, 1396; F. Osmond and G. Cartaud, *Rev. de Métallurgie*, 1904, 1, 69.

formation curves, so that each alloy of the group has two critical temperatures, t_2 and t_1 . The lower (t_1) curve falls much more steeply than the upper (t_2) curve. Between these curves each alloy is capable of existing in two conditions, a magnetic and a non-magnetic. A magnetic alloy loses its magnetism on heating at t_2 , whilst an alloy cooling from a high temperature remains non-magnetic until t_1 is reached. In other words, the transformation is overstepped in both directions, the region lying between the two curves increasing in breadth with increasing nickel content, until the range within which both the magnetic and non-magnetic alloys may exist amounts to 600° when the nickel reaches 25 per cent. Beyond this limit, the transformation becomes almost exactly reversible, and the curve with a maximum at 70 per cent. Ni represents the change both on heating and on cooling with fair approximation. The nature of the metastable conditions in the alloys of nickel and iron will be discussed later, in connection with the structure of the meteoric irons (p. 383).¹

A very interesting group of magnetic alloys consists of ternary alloys of manganese, often referred to as Heusler's alloys. It was observed in 1892² that whilst ferro-manganese and ferro-aluminium are non-magnetic, ternary alloys containing only 10–14 per cent. of iron, the remainder being manganese and aluminium, are strongly magnetic, some members of the series being comparable with iron itself. The observation was subsequently made³ that alloys of copper and manganese become

¹ For the magnetism of the nickel-iron alloys, see J. Hopkinson, *Proc. Roy. Soc.*, 1890, **47**, 23; C. E. Guillaume, *Compt. rend.*, 1897, **124**, 176, 1515; **125**, 235; 1898, **126**, 738; *Étude des Alliages*, 459; L. Dumas, *Compt. rend.*, 1900, **130**, 357; E. Dumont, *ibid.*, 1898, **126**, 741; H. Tomlinson, *Proc. Roy. Soc.*, 1884, **56**, 103.

² T. W. Hogg, *Chem. News*, 1892, **66**, 140.

³ See F. Heusler, *Verh. deut. physikal. Ges.*, 1903, **5**, 219; W. Stark and E. Haupt, *ibid.*, 222; E. Take, *Verh. deut. physikal. Ges.*, 1905, **7**, 133; *Ann. Physik.*, 1906, [iv.] **20**, 849; P. Asteroth, *Verh. deut. physikal. Ges.*, 1908, **10**, 21; H. Fassbender, *ibid.*, 256; F. Heusler and F. Richarz, *Zeitsch. anorg. Chem.*, 1901, **61**, 265; J. A. Fleming and R. A. Hadfield, *Proc. Roy. Soc.*, 1905, **76A**, 271; A. Gray, *ibid.*, 1906, **77A**, 256; A. D. Ross, *Proc. Roy. Soc. Edin.*, 1907, **27**, 88; A. D. Ross and R. C. Gray, *ibid.*, 1909, **29**, 274; A. A. Knowlton, *Phys. Rev.*, 1910, **30**, 123; 1911, **32**, 54. A general discussion of the subject, including papers by various authors, is to be found in *Trans. Faraday Soc.*, 1212, 8.

magnetic when aluminium, tin, antimony, bismuth, arsenic, or boron are added in certain proportions. The copper-aluminium-manganese alloys have been most fully investigated, and are found to behave in every respect as ferromagnetic substances. Quenching from a high temperature frequently renders the alloys non-magnetic, their magnetic properties being developed by heating to 110° or 140° .

It is evident from the variability of the magnetic properties that we have to deal with a system having a great tendency to assume a metastable condition. Take has found that the transformation temperature is raised by repeated heatings. The cooling curves of the alloys are marked by several arrests, some of which are accompanied by changes of volume, indicating that the reactions in solid solution are of a complex character.

Copper and manganese are isomorphous, whilst aluminium forms compounds with both, amongst the compounds which have been definitely recognized being Cu_3Al and Mn_3Al . Plotting the results hitherto obtained in this ternary series on a triangular diagram, it is found that the most strongly magnetic members of the series fall on a line connecting these two compounds, and are therefore to be considered as mixtures, probably isomorphous, of Cu_3Al and Mn_3Al . The appearance of magnetic properties is certainly connected with the formation of these inter-metallic compounds, and is not to be attributed, as was at first supposed, merely to a displacement of a transformation point of manganese by alloying with other metals.

Several other compounds of manganese, especially MnB , MnSb , MnAs , Mn_4Sn , and MnBi , are strongly magnetic.¹ The behaviour of the bismuthide is remarkable, in view of the fact that bismuth itself is diamagnetic, that is, its susceptibility has a negative value. The relation of magnetic properties to constitution has been determined for several series of alloys by Honda.²

¹ See the papers of F. Heusler, quoted on p. 272, and also E. Wedekind, *Ber.*, 1907, 40, 1259; *Zeitsch. physikal. Chem.*, 1909, 66, 614; E. Wedekind and T. Veit, *Ber.*, 1911, 44, 2663.

² K. Honda, *Ann. Physik.*, 1910, [iv] 32, 1003. For the magnetic

HYSTERESIS AND COERCIVE FORCE

When a metal or alloy is submitted to the action of an alternating magnetizing field, a certain quantity of energy is dissipated in each cycle by conversion to heat. This quantity, represented graphically by the area of the corresponding loop in the I-H curve, obtained after the material has been brought into a steady state by several repetitions of the cycle, is called the *hysteresis*, and its amount governs the applicability of the material in electrical constructions. Transformer iron, for example, which has to pass through rapidly repeated magnetic cycles, must be a variety exhibiting the smallest possible hysteresis, in order to avoid undue heating of the metal and loss of energy. The interval between the transformation temperatures on heating and on cooling in the case of such materials as the irreversible nickel steels (p. 272) is sometimes called the *temperature hysteresis*, but must not be confused with the quantity just described.

As the hysteresis evidently represents the energy absorbed in twice reversing the polarized position of the molecules of the material,¹ it has a great importance in connection with molecular theories of magnetism.² Soft, pure iron has the lowest hysteresis of any known ferromagnetic substance. Hardening by mechanical work has the effect of greatly increasing the hysteresis, whilst the addition of other elements, especially carbon, as a rule, also increases it. It is true that certain alloys of iron, in particular those containing small quantities of aluminium, have been found to have even a lower hysteresis than the purest specimens of iron; but it is probable that the greater part of the effect is due to the action of the added metal in removing oxygen, which is generally present in iron.

properties of a very extensive series of alloys of iron, see the papers by Barrett, Brown, and Hadfield, cited on p. 259.

¹ J. A. Ewing, *Proc. Roy. Soc.*, 1890, 48, 342.

² See, for a review of the subject, E. Warburg, *Rapp. Congr. intern. Phys.*, 1900, ii. 509.

The hysteresis of the Heusler alloys presents a number of highly interesting features, the phenomena having been as yet very incompletely explained. Reference must be made to the papers quoted on p. 272 for details.

In the construction of permanent magnets, the properties required are the reverse of those demanded in transformer iron. The *coercive force* of such materials is said to be large. The coercive force of iron is greatly increased by the presence of carbon and other elements held in solid solution, hence permanent magnets are made of steel hardened by quenching. Even pure iron has an increased coercive force after quenching,¹ possibly due to internal strain. Tungsten and molybdenum are particularly effectual in increasing the coercive force. It is evident that in all future investigations of this very important subject, attention should be paid to the relations between the heat treatment of the materials examined and the equilibrium diagram of the alloys as derived from thermal and micrographic observations.

¹ E. Maurer, *Metallurgie*, 1909, 6, 33.

CHAPTER XIII

ELECTROMOTIVE FORCE AND CORROSION

THE electric potential assumed by an alloy in contact with an electrolyte is a property of high diagnostic value in the study of constitution, and at the same time has great practical importance as determining the liability of the alloy to corrosion when exposed to the influence of electrolytes alone or in contact with other metals. The experimental determination of the potential is complicated by the fact that alloys, not being elementary substances, are liable to react with the electrolyte in such a way as to bring about a change of composition at the surface of the electrode, causing the potential observed to vary with the time. Further, if the alloy be heterogeneous in structure, local electrolytic actions take place between the micrographic constituents at the surface, again resulting in an alteration of the effective composition of the alloy, and consequently in a variation of the potential. A third difficulty arises from the necessity of finding a suitable electrolyte with which the alloy can be in equilibrium. Whilst it is sufficient to examine a pure metal in contact with a solution of one of its own salts, a complex electrolyte containing definite proportions of salts of the component metals is required in the case of alloys.

It is to this last condition, so commonly overlooked, that the uncertainty of the results obtained by most of the earlier investigators is due. With a view to the practical study of corrosion, it was usual to compare the electromotive force developed by various alloys when connected with some standard metal such as copper, in a solution of an alkaline salt, or of an acid, or in sea-water.

The earliest determinations of a more scientific character are due to Laurie,¹ who employed a solution of a salt of one of the component metals as the electrolyte, and made efforts to avoid polarization. Thus alloys of copper were compared with copper in a solution of cuprous iodide, copper-tin alloys in stannous chloride compared with copper in cupric sulphate, separated by a porous partition, and so on. Only relative values were obtained in this way, as account was not taken of the concentration of the electrolyte; but marked discontinuities in the E.M.F.-composition curves were observed in several cases, the copper-tin alloys, for instance, exhibiting a sudden change of potential at the composition corresponding with the formula Cu_3Sn .

In his numerous series of measurements, Herschkowitsch² employed as electrolyte a normal solution of a salt of the more positive metal, the comparison electrode being a rod of the less positive metal. Characteristic curves were obtained for a large number of alloys, the discontinuities being very clearly marked in many instances. Whilst, however, this method of working is satisfactory when the two metals composing the alloy differ widely in their position in the electrochemical series, it fails in other cases, as the electrolyte used is not one with which a true equilibrium is possible. The conditions of equilibrium have been fully investigated from the point of view of the phase rule,³ and the following are the principal conclusions that have been reached.

I. The two metals do not form either compounds or solid solutions.

The potential difference between a metal, M_1 , and a solution containing only a salt, M_1Z , is

$$E_1 = 0.860 \frac{T}{n_1} \ln \frac{P_1}{p_1} \times 10^{-4} \dots \dots (1)$$

where n_1 is the valency of the metal, P_1 its solution pressure,

¹ A. P. Laurie, *Trans. Chem. Soc.*, 1888, **53**, 104; 1889, **55**, 677; 1894, **65**, 1031; *Phil. Mag.*, 1892, [v.] **33**, 94; *Zeitsch. physikal. Chem.*, 1909, **67**, 627.

² M. Herschkowitsch, *Zeitsch. physikal. Chem.*, 1898, **27**, 123.

³ W. Reinders, *ibid.*, 1903, **42**, 225.

and p_1 the ionic concentration of the metal in the electrolyte; 0.860×10^{-4} is the "electrolytic gas constant," R/F ; T is the absolute temperature.¹ If some of the M_1 ions are replaced by M_2 , p_1 becomes smaller, and E_1 is increased. The potential difference between the second metal, M_2 , and a solution of its salt is similarly altered by the presence of M_1 . The two logarithmic curves intersect at a point at which $E_1 = E_2$, so that

$$\frac{1}{n_1} \ln \frac{P_1}{p_1} = \frac{1}{n_2} \ln \frac{P_2}{p_2} \dots \dots \dots (2)$$

or, if $n_1 = n_2$, $P_1 : P_2 = p_1 : p_2$, or the ratio of the ionic concentrations under conditions of equilibrium is equal to the ratio of the solution pressures. If these differ very widely, as in the case of copper and zinc, p_2 becomes very small, and a mere trace of the metal M_2 is sufficient for equilibrium; Herschkowitsch's procedure is therefore justified. It is evident, however, that when P_1 and P_2 are approximately equal, as for silver and mercury, a mixed electrolyte of suitable composition is necessary.

II. The two metals form a homogeneous solid solution (the same reasoning applies also to liquid amalgams).

Equation (2) applies to the state of equilibrium if P_1 and P_2 are now taken to represent the partial solution pressures of M_1 and M_2 respectively. The solution pressure of M_1 is lowered by the presence of M_2 in solid solution, and for small concentrations the lowering may be safely assumed to be proportional to the molecular concentration of M_2 in the electrode. If this concentration = x , then $P_1' = P_1(1 - x)$. $P_2' = Kx$, where K is the solution pressure of M_2 in the presence of M_1 , and is probably rather less than P_2 . Then

$$\frac{1}{n} \ln \frac{P_1'(1-x)}{p_1} = \frac{1}{n_2} \ln \frac{Kx}{p_2} \dots \dots \dots (3)$$

or, if $n_1 = n_2$,

$$\frac{p_2}{p_1} = \frac{K}{P_1'} \cdot \frac{x}{1-x} \dots \dots \dots (4)$$

¹ W. Nernst, *Zeitsch. physikal. Chem.*, 1889, 4, 129.

or the ratio of the two metallic ions in the electrolyte is to the molecular ratio of the two atoms in the alloy as $K : P_1'$.

As before, if K and P_1' differ very widely, the electrolyte will contain almost exclusively ions of the more positive metal, whatever may be the concentration of that metal in the electrode. The E.M.F. is thus a logarithmic function of x . In

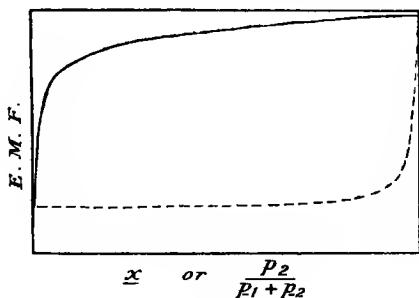

FIG. 89.

Fig. 89 the full curve represents the variation of E with x , the dotted curve that of E with $\frac{p_2}{p_1 + p_2}$.

If the two metals form two series of solid solutions separated by a gap, the two saturated solid solutions are in equilibrium with one another and with the electrolyte. Within the limits of composition represented by the gap, the E.M.F. is therefore constant. Such a condition is presented by the cadmium amalgams, the E.M.F. curves of which, for three different temperatures, are shown in Fig. 90.¹ The electrolyte used was a solution of cadmium sulphate. The width of the gap is seen to diminish as the temperature rises; and these E.M.F. measurements were, in fact, employed to determine the slope of the lines DP and EQ in Fig. 21 (p. 54). On each E.M.F. curve, the first horizontal portion represents the interval between the liquidus and solidus curves, and the second the interval between the lines DP and EQ .

¹ H. C. Bijl, *Zeitsch. physikal. Chem.*, 1902, 42, 641.

III. The two metals form a compound.

The problem of determining the E.M.F. is now complicated by the necessity of making an assumption as to the nature of the ions sent out by the compound. Reinders, making the assumption that it sends out ions of the same composition as the compound, concludes that the E.M.F. is a maximum when the ratio of the ionic concentrations = the atomic ratio of the metals in combination.

Taking the simplest case, that of a series in which a single compound occurs and solid solutions are not formed, as in the

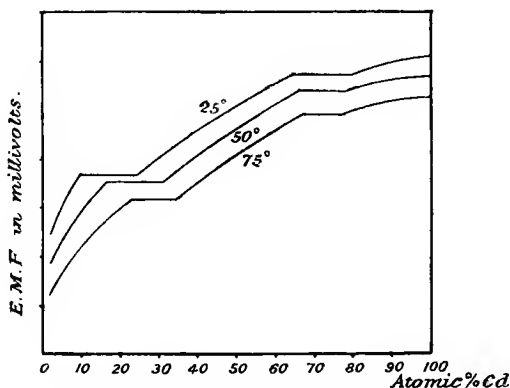

FIG. 90.—E.M.F. curves of cadmium amalgams at 25°, 50°, and 75°.

series magnesium-lead, magnesium-tin, or magnesium-bismuth, the E.M.F. curve has the form shown in Fig. 91. The potential is that of the more positive metal, so long as any of the latter is present as a distinct phase. At the composition of the compound, the potential suddenly falls to that of the compound or of the second metal, whichever has the lower solution pressure. If solid solutions are formed, or if the metals form several compounds, the curves obtained present a combination of the characters described. Thus the E.M.F. of thallium amalgams, measured against a mercury electrode, increases in a regular manner from practically zero for pure

mercury¹ to a constant value at 33.3 atomic per cent. at 0°, indicating that amalgams containing less than that proportion of thallium consist of solid solutions of the compound Hg_2Tl in mercury, whilst amalgams richer in thallium consist of conglomerates of crystals of Hg_2Tl and thallium.²

If the compound forms solid solutions with both its components, its composition is not indicated by a discontinuity in the E.M.F. curve at that point. In Fig. 92 a system, the freezing-point curve of which is indicated in the upper diagram,

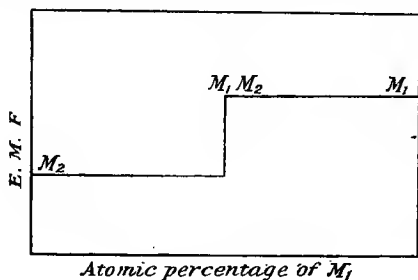

FIG. 91.

is likely to give an E.M.F. curve like that represented in the lower diagram. On the supposition that a discontinuity indicates the formation of a compound, the composition of the latter would probably be put at A rather than at B, and a wrong formula would in this way be assigned to the compound.

A very numerous series of recent determinations are due to Pushin and his collaborators,³ who, finding the application of the rules for the composition of the electrolyte given above to present certain difficulties, have usually employed acids

¹ Not exactly zero, as the one electrode is in contact with an electrolyte consisting principally of thallos chloride, whilst the other is in contact with mercurous chloride and potassium chloride (calomel electrode).

² A. Sucheni, *Zeitsch. Elektrochem.*, 1906, 12, 726.

³ N. A. Pushin, *Ź. Russ. Phys. Chem. Soc.*, 1907, 39, i, 13, 353, 528, 869; *Zeitsch. anorg. Chem.*, 1907, 56, 1; N. A. Pushin and N. P. Pashsky, *Ź. Russ. Phys. Chem. Soc.*, 1908, 40, 826; N. A. Pushin and P. N. Laschtschenko, *ibid.*, 1909, 41, 23; *Zeitsch. anorg. Chem.*, 1909, 62, 34.

or alkalis forming sparingly soluble salts with the more positive metal, a simple salt of the more positive metal being used when the solution pressures differ widely. Thus the potential of the alloys of lead with the platinum metals

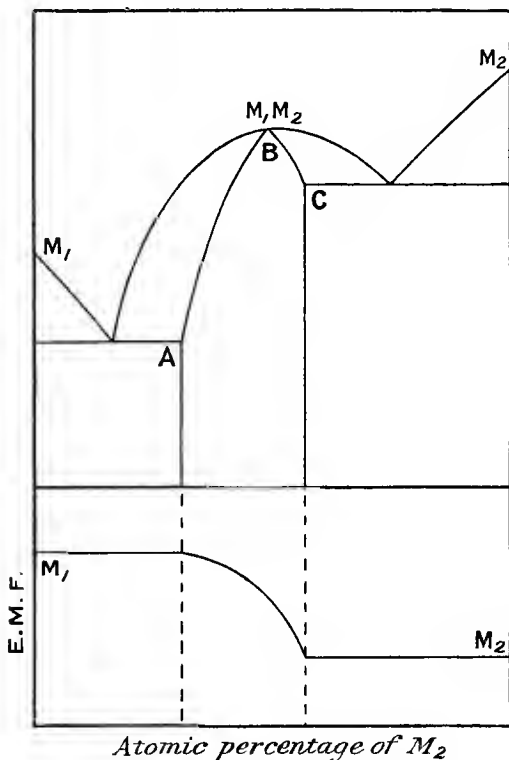

FIG. 92.—Constitution and E.M.F.

was measured in a normal solution of lead nitrate against lead. Calcium hydroxide was found to be the most suitable electrolyte for aluminium alloys and potassium hydroxide for the alloys of lead and tin. Several typical curves selected from Pushin's results are collected in Fig. 93. Antimony and bismuth, being isomorphous, give a continuous

curve. The antimony-nickel curve indicates the formation of two compounds, $SbNi$ and $SbNi_3$, both of which retain small further quantities of antimony, but not of nickel, in solid solution. The lead-platinum curve, on the other hand, has two sudden steps, corresponding with the compounds Pb_2Pt and $PbPt$, neither of which forms solid solutions. Lastly, the lead-tin curve shows the formation of a solid solution of tin in

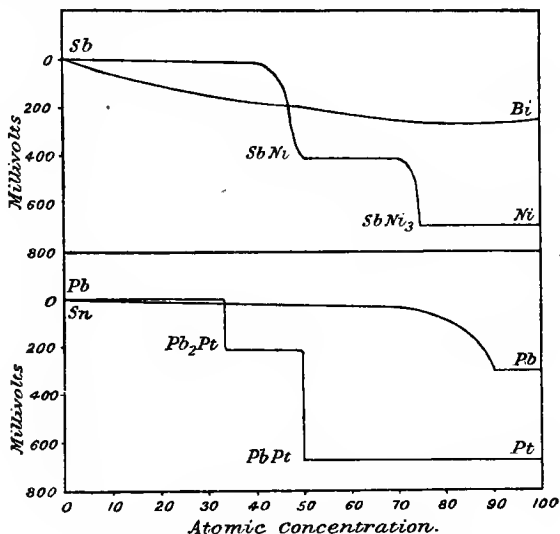

FIG. 93.—Typical E.M.F. curves of alloys.

lead. The form of the curve, which resembles that of a series containing a compound, is probably due to the difficulty of attaining equilibrium, the alloys at the lead end containing free lead coating the crystals of the solid solution.

In the practical execution of potential measurements, the metals and alloys are conveniently employed in the form of rods immersed in the electrolyte contained in glass tubes out of contact with air. The E.M.F. is measured against that of a standard cell by the compensation method.¹ A capillary

¹ See W. Ostwald and R. Luther, *Physico-Chemical Measurements*.

electrometer is the most convenient instrument for obtaining compensation, especially in one of the closed forms now available.¹

The potential indicated when an alloy is first immersed does not remain constant, owing to changes at the surface of the electrode, but changes rapidly at first, then more slowly, generally approaching asymptotically a constant value. It is this value that observers have recorded, although its acceptance as representing the true potential of the alloy is certainly open to objection. The change is partly due to the formation of layers of gas on the electrodes, and partly to local reactions between the micrographic constituents of the alloy. Thus, if we construct a circuit of copper and platinum in a solution of copper sulphate, the E.M.F. of the combination gradually falls to zero, owing to the deposition of copper on the platinum.² A metallic circuit is formed wherever two different micrographic constituents are in contact at the surface of the electrode, and such local changes must alter the potential.³ The recorded data employed in the construction of the E.M.F. curves of alloys refer entirely to such final constant values. The alloys to be compared must be in a state of equilibrium, and must be free from mechanical work. Under these conditions, the E.M.F.-composition curve takes the following forms:—

1. All the alloys of the series consist of conglomerates of the pure metals. The potential is throughout that of the more positive metal, and the curve is a horizontal straight line.
2. The metals form a continuous series of solid solutions. The potential varies in a continuous manner, and the curve has a logarithmic form.
3. Solid solutions of limited concentration are formed.

¹ S. W. J. Smith, *Phil. Mag.*, 1903, [vi.] 5, 398; H. J. S. Sand, *Trans. Faraday Soc.*, 1909, 5, 159.

² R. Luther, *Zeitsch. physikal. Chem.*, 1901, 36, 385; F. Fischer, *ibid.*, 1905, 52, 55.

³ See, on the formation of alloys from solutions and polarization from this cause, F. Mylius and O. Fromm, *Ber.*, 1894, 27, 630; A. Coehn, *Zeitsch. physikal. Chem.*, 1901, 38, 609.

The curve is smooth within the region of solid solutions, as in (2); the gap in the series is represented by a horizontal portion of the curve.

4. A single compound is formed, solid solutions being absent. The curve is composed of two horizontal portions, connected by a vertical line representing a sudden change of potential.

5. Several inter-metallic compounds occur in the series, but solid solutions are absent. The curve is composed of several steps like those of (4).

6. Both compounds and solid solutions are formed. The curve is a combination of (4) or (5) with (3). A vertical line, that is a sudden fall of potential at a certain composition, indicates the existence of a compound having exactly that composition. If two horizontal portions are connected by smooth curves, and not by vertical lines, the beginning and ending of these sloping portions indicate the appearance of new phases. If a compound forms solid solutions with both components, there is no sudden fall of potential, and the composition of the compound cannot be inferred directly from the curve.¹

E.M.F. OF POLYMORPHIC MODIFICATIONS

The determination of E.M.F. may also be utilized as a means of detecting polymorphic change, and of measuring the temperature of transformation. Since two polymorphic modifications of a metal will, in general, differ in the amount of energy they contain, their solution-pressures will be different and they will assume different potentials on being brought into the same electrolyte. This fact has been utilized in the study of the transformation of ordinary into grey tin,² the two modifications being made the electrodes of a cell with a solution of ammonium stannichloride, and the E.M.F. developed by the cell determined at different temperatures.

By the use of quenched specimens, the E.M.F. of phases

¹ The E.M.F. of a few ternary alloys has been studied by R. Kremann and F. Hofmeier, *Monatsh.*, 1911, **32**, 597.

² E. Cohen and C. van Eijk, *Zeitsch. physikal. Chem.*, 1899, **30**, 601.

which are only stable at high temperatures, and are consequently inaccessible to direct electrolytic measurements, may be compared with that of the phases stable at ordinary temperatures. This method has proved of considerable value in the study of the state of solution of carbon in iron under different conditions,¹ and is capable of further extension.

A metal or alloy which has been subjected to rolling or hammering, or has been in other ways mechanically strained, has a different potential from one which is in a soft or annealed state. The strained metal contains a larger quantity of energy than the unstrained, and may therefore be expected to have the higher solution pressure. In accordance with this, most worked metals become the anode when connected in an electrolyte with a piece of the same metal in an unstrained state.² Metals may be very severely strained by being caused to flow through a narrow orifice. The following results were obtained by Spring,³ using such flowed metals, the comparison electrode being a wire of the same material, heated to such a temperature as to remove all strain:—

Sn in SnCl ₂	+ 0·00011 volt.
Pb „ Pb(NO ₃) ₂	+ 0·00012 „
Cd „ CdCl ₂	+ 0·00020 „
Ag „ AgNO ₃	+ 0·00098 „
Bi „ Bi(NO ₃) ₃ , $\frac{1}{2}$ HNO ₃	- 0·00385 „

The plus sign indicates that in the first four instances the flowed metal became the anode. The negative sign opposite Bi indicates that the E.M.F. developed is in the reverse direction. Bismuth, unlike the other metals named, increases in density when caused to flow. It is remarkable that bismuth wire obtained in this way is sufficiently flexible to be tied in a knot, but immediately becomes brittle on annealing.

Cadmium is so sensitive that merely rubbing the surface

¹ C. Benedicks, *Thèse pour le Doctorat*, Upsala, 1904; E. Heyn and O. Bauer, *J. Iron Steel Inst.*, 1909, i. 109.

² C. E. Fawsitt, *Proc. Roy. Soc. Edin.*, 1906, 25, 2; T. Andrews, *Proc. Inst. Civil Eng.*, 1894, 118, 356.

³ W. Spring, *Bull. Acad. roy. Belg.*, 1903, 1066.

with emery paper is sufficient to make that specimen the anode when compared with an untreated specimen.

Attempts to measure the E.M.F. of a metal (iron) during the process of straining below the elastic limit have shown that the change produced, if any, is very small, and is liable to be masked by accidental variations.¹ There appears to be a small increase of solution pressure at the moment that elongation takes place. The amount of energy stored up during straining has been calculated,² but the increase of potential theoretically produced thereby falls within the limits of experimental error.

A qualitative test for the presence of a given solid phase in an alloy may be applied in some cases, by observing the ability or inability of the alloy to precipitate another metal from solutions of its salts.³ Thus zinc, or alloys containing the zinc phase, precipitate copper from its salts, even when the concentration of copper ions in the latter is very small, as in copper cyanide or cupric-ammonium salts. A solid phase in which zinc is present in combination, however, may have a solution pressure so low that it is unable to precipitate copper. Thus of the alloys of zinc and copper, those containing 100-59 per cent. Zn precipitate copper from all its salts, including those in which copper is present as complex ions. Alloys containing 55-40 per cent. Zn precipitate copper from the ammonium compounds, but not from the cyanide or thiocyanate; whilst those containing 38-0 per cent. Zn are only capable of precipitating solutions in which copper ions are abundant, such as the chloride.⁴ It has been attempted to found on this basis a quantitative method of determining the partial solution pressures of metals in solid solution, but the process can hardly be said to have more than a qualitative value.

¹ T. W. Richards and G. E. Behr, *Carnegie Inst. Washington*, Publ. 61, 1906.

² C. Barus, *Amer. J. Sci.*, 1889. [iii.] 38, 193.

³ O. Sackur, *Arb. k. Gesundheitsamt*, 1904, 20, 512; 22, 187; O. Sackur and H. Pick, *Zeitsch. anorg. Chem.*, 1908, 58, 46.

⁴ O. Sackur, *Ber.*, 1905, 38, 2186.

CORROSION

With the exception of the so-called "noble" metals, all metals and alloys are liable to be attacked and dissolved by solutions of acids or salts. It may be considered as established that all such corrosion is electrolytic in character, and that the presence of substances capable of forming among themselves a voltaic circuit is necessary in order that solution may take place. It is a familiar fact that metals of a high degree of commercial purity are less readily dissolved by acids than impure metals. Pure specimens of tin, for example, are very little attacked by hydrochloric acid; but the addition of a little platinum chloride to the acid, by depositing spongy platinum on the surface of the metal, and so setting up very numerous local voltaic circuits, causes solution to take place very rapidly. Quantitative experiments on the velocity of solution of metals indicate that the process is invariably dependent on the formation of local circuits.¹ In ordinary metals, the necessary conditions are afforded by the presence of minute specks of impurity. A perfectly pure metal, if such could be obtained, would probably remain unattacked by dilute acids. The distribution of the impurity through the mass, as in a solidified metal containing small quantities of eutectic, increases the number of local couples and hence also the velocity of solution.

The rusting of iron is such a process. Iron, even of the highest attainable degree of purity, contains small particles of carbide, phosphide, or other substance capable of forming with the iron in presence of an electrolyte a voltaic circuit. The presence of liquid water is necessary, as iron does not rust in dry steam, even when the latter contains carbon dioxide. Lastly, an acid or other electrolyte must be present, as exposure to water and oxygen alone does not cause rusting.²

¹ T. Ericson-Aurén and W. Palmaer, *Zeitsch. physikal. Chem.*, 1901, 39, 1; 1903, 45, 182; 1906, 56, 689. See also E. Brunner, *ibid.*, 1905, 51, 95.

² The literature dealing with the rusting of iron is extensive and controversial. The experiments of G. T. Moody (*Trans. Chem. Soc.*, 1906,

The electrolytic potential of a strained metal being different from that of the same metal in an unstrained state, it is probable that the presence of strained areas on the surface of a specimen taken for an experiment may suffice to provide the local couples necessary for corrosion. As it is difficult to prepare any metallic specimen free from surface strain, this cause may be responsible for the initiation of corrosion in many experiments conducted with metals supposed to be pure. It may be shown experimentally that anodic and cathodic areas are formed on any piece of iron which is undergoing corrosion by the following device.¹ A dilute solution of potassium ferricyanide and phenolphthalein in water is thickened slightly with gelatin to prevent convection currents. If a piece of iron is immersed in this reagent, blue areas appear wherever the iron is anodic, owing to the formation of ferrous ferricyanide where ferrous iron is passing into solution, and a pink area at each cathode, owing to the setting free of alkali at that point. This "ferroxyl" reagent is a sensitive means of detecting corrosion. In an electrolyte free from oxygen, the action soon comes to an end, owing to the formation of a layer of gaseous hydrogen on the cathode areas, setting up an E.M.F. of polarization, but in presence of oxygen, this layer is removed by oxidation, and at the same time ferrous salts are eliminated from the solution by precipitation. In water containing carbon dioxide, the process is one of dissolution of iron as ferrous hydrogen carbonate with liberation of hydrogen, followed by oxidation of a part of the hydrogen and of the ferrous salt, precipitating iron rust, which contains both ferrous

89, 720; *Proc. Chem. Soc.*, 1903, 19, 157, 239; 1907, 23, 84) are conclusive in favour of the view that iron does not rust in presence of water and oxygen alone. See, for experiments under various conditions: W. R. Dunstan, H. A. D. Jowett, and E. Goulding, *Trans. Chem. Soc.*, 1905, 87, 1548; W. R. Whitney, *J. Amer. Chem. Soc.*, 1903, 25, 394; W. H. Walker, A. M. Cederholm, and L. N. Bent, *ibid.*, 1907, 29, 1251; J. A. N. Friend, *J. Iron Steel Inst.*, 1908, i, 5; W. H. Walker, *ibid.*, 1909, i, 69; B. Lambert and J. C. Thomson, *Trans. Chem. Soc.*, 1911, 97, 2426; J. A. N. Friend and J. H. Brown, *ibid.*, 1302.

¹ W. H. Walker, *loc. cit.*, and A. S. Cushman, *Trans. Amer. Electrochem. Soc.*, 1907, 12, 403.

carbonate and ferric hydroxide.¹ The presence of copper, platinum, or similar metal, facilitates corrosion, and this has an important bearing on the means adopted to protect iron against corrosion. The processes of protection consist in coating with a substance having less tendency to corrode than iron. Leaving aside painting, which as a mechanical device does not call for consideration here, three such substances are in common use for the purpose, namely: zinc, tin, and the magnetic oxide of iron, Fe_3O_4 . Coating iron or steel with zinc constitutes the process of galvanizing. Zinc alone is not readily corroded, and galvanized iron is thereby protected. Should any portion of the iron surface be exposed, as through a defect in the protecting layer, a zinc-iron couple is formed. Zinc has a much higher solution pressure than iron, and passes into solution, the iron becoming the cathode, and therefore remaining unattacked so long as zinc still exists in the neighbourhood. Zinc plugs are even used on iron screw-propellers and other parts exposed to corrosion by sea-water, although it is very doubtful whether more than a small local area can be protected by such means.

Coating iron or steel with tin is employed in the production of ordinary tin-plate. Like zinc, tin is little corroded by mere exposure to water containing carbon dioxide or traces of other acids, and the iron is therefore protected so long as the tin coating remains intact, but the behaviour of a tin-iron couple is quite different from that of a zinc-iron couple, the iron becoming the anode.

Magnetic oxide of iron, formed by heating iron in air or steam, also forms a cathode, and thus hastens corrosion when the coating has been broken through.

Alloys consisting of two solid phases in a state of mechanical mixture obviously present the condition necessary for electrolytic corrosion. If we place an alloy of copper and zinc, such as Muntz's metal, containing about 40 per cent. Zn, and composed of an intimate mixture of α and β solid solutions, in hydrochloric acid, local couples are at once formed, in which the α crystals are the cathodes, and the β the anodes. The

¹ G. T. Moody, *loc. cit.*

latter constituent, containing a larger proportion of zinc than the former, is preferentially dissolved. That a surface of Muntz's metal loses zinc and copper at approximately the same rate¹ is partly due to exfoliation of the α crystals, loosened by solution of the inter-crystalline β constituent, and not entirely to simultaneous solution of copper and zinc. That such simultaneous solution of the two metals does occur, however, when the alloy is made the anode in an electrolyte is proved by a series of experiments in which normal solutions of different alkali salts were used.² On passing a current between the

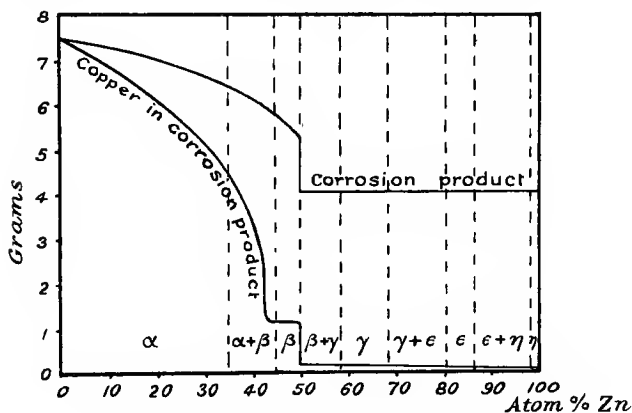

FIG. 94.—Electrolytic corrosion of copper-zinc alloy.

alloy and a platinum cathode, solution of copper and zinc occurs, causing the formation of a flocculent precipitate. The results obtained in sodium chloride are represented graphically in Figs. 94 and 95. In the former figure, the weight of the corrosion product and the weight of copper in it are plotted against the original composition of the test-pieces. The limits of the solid solutions are indicated by vertical dotted lines. In Fig. 95 the percentage of zinc in the corrosion product

¹ J. G. A. Rhodin, *Trans. Faraday Soc.*, 1905, 1, 119.

² A. T. Lincoln, D. Klein, and P. E. Howe, *J. Physical Chem.*, 1907, 11, 501; A. T. Lincoln and G. C. Bartells, *ibid.*, 1908, 12, 550; *Trans. Amer. Electrochem. Soc.*, 1908, 13, 331; A. T. Lincoln, *ibid.*, 11, 43.

is plotted against the percentage in the original specimen. If the alloy contains less than 40 atomic per cent. Zn, the corrosion product has the same composition as the test-piece, which is therefore unaltered by corrosion. These alloys correspond with the α and $\alpha + \beta$ series of solid solutions. With the appearance of the γ phase, the percentage of copper removed drops almost to zero, zinc only being dissolved, and a layer rich in copper being formed on the surface of the anode. This layer may scale off as corrosion proceeds, so that if the corrosion were determined by the loss of the anode, instead of

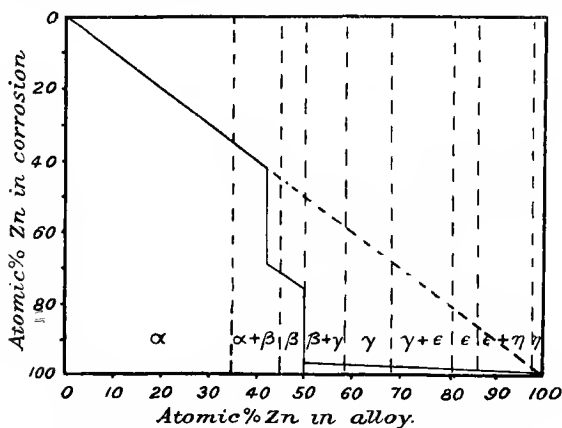

FIG. 95.—Electrolytic corrosion of copper-zinc alloys.

by analysing the corrosion product, it would appear that copper as well as zinc was removed from the anode. A few tests of the chemical corrosion were made by the same authors, no current being passed, but the results obtained were indecisive. Microscopical examination, however, proves that the surface is by no means equally attacked. Alloys consisting of the $\alpha + \beta$ phases, within which range Muntz's metal and similar alloys fall, are at first attacked only on the β areas, the zinc from which is rapidly removed, leaving an alloy very rich in copper, and not until this change has penetrated to a considerable depth is the α constituent attacked, undergoing a

similar change. The nature of the process demands further investigation, but it is not justifiable to assume that chemical corrosion, due only to the influence of local couples, follows exactly the same course as corrosion under the influence of a considerable external E.M.F.

The addition of tin to copper-zinc alloys is frequently adopted with the object of lessening the corrosion in such cases as that of bolts exposed to the action of sea-water, the quantity of tin amounting to 1 to 1.5 per cent. In Lincoln's experiments the tin was found to exert very little influence on the corrosion, but it is improbable that this also applies to simple chemical corrosion. The effect of the addition of tin up to 1.4 per cent. to an $\alpha + \beta$ copper-zinc alloy is to displace the limits of the α and β phases, without altering the structure in any other way, the tin being about equally distributed between the two phases, whilst the addition of any larger quantity of tin leads to the appearance of a new constituent, an alloy of copper and tin having approximately the composition Cu_4Sn .¹

The electrolytic corrosion of the alloys of copper and tin² also shows discontinuities corresponding with the disappearance of certain solid phases. The alloys rich in tin frequently become passive owing to the formation of an insoluble layer of stannic oxide. Considerable exfoliation takes place from the surface of some of the copper-tin, as well as of the copper-zinc alloys, and in further investigations of this kind it will be necessary to distinguish clearly between the removal of metal by true solution and by mere mechanical flaking.

¹ L. Guillet, *Rev. de Métallurgie*, 1906, 3, 243.

² B. E. Curry, *J. Physical Chem.*, 1906, 10, 474; *Trans. Amer. Electrochem. Soc.*, 1906, 9, 173; F. Giolitti and O. Ceccarelli, *Gazzetta*, 1909, 39, ii, 557. The corrosion of aluminium-copper alloys has been examined in a similar manner by W. S. Rowland, *J. Physical Chem.*, 1908, 12, 180.

THE CHEMICAL EXAMINATION OF RESIDUES

The action of a chemical reagent on an alloy may be continued until the reagent ceases to dissolve anything further, and the nature of the residue remaining may be investigated as a means of determining the proximate composition of the original alloy. For this purpose the material is generally reduced to a fine state of division by filing or powdering, and is treated with successive quantities of the reagent so long as any metal passes into solution. This method was formerly a favourite one for determining the formulæ of the inter-metallic compounds contained in alloys. For example, a series of alloys of a metal with zinc of varying composition, but presumed to contain an excess of free zinc, would be extracted with dilute hydrochloric acid to remove this excess, and the residues submitted to analysis. If the residues from alloys originally differing from one another proved to have the same composition, a formula was calculated and assigned to the substance unattacked by the reagent. The greater number of the formulæ of inter-metallic compounds found in text-books of inorganic chemistry have been arrived at by this means, and the method is still frequently applied by French chemists, and other isolated examples of its use occur from time to time.¹ There are, however, numerous objections, of a theoretical and practical character, to the employment of such a method, and it can at most be admitted as an auxiliary in certain cases. Formulæ based solely on the behaviour of alloys towards reagents must therefore be refused recognition until confirmed by more trustworthy methods.

To deal with the practical difficulties first, it is frequently the case that the action of the reagent is brought to a standstill after a time by purely mechanical hindrances. For example, the extraction of free silicon from alloys by means of alkali hydroxide or carbonate has been repeatedly employed to fix the formulæ of metallic silicides. It has been shown,

¹ For example, in a study of the silicides of copper, M. Philips, *Metallurgie*, 1907, 4, 587, 613.

however, by Guertler¹ that the action of the alkaline solution is not confined to the free silicon, but that the silicides are also slowly attacked. The removal of combined silicon leads to the formation of a layer of metal on the particles of the residue, preventing further action. The analysis of the residue after such treatment obviously does not correspond with the formula of the silicide. By treating the residue with dilute acid to remove the metallic layer, and repeating the extraction with alkali, the whole of the alloy may generally be brought into solution. Similar objections apply to the extraction of alloys with acids, bromine water, etc.

Apart from these practical difficulties, which are sufficiently serious, the method is defective in principle. The preceding sections of this chapter have shown how complex is the action of reagents, whether alone or assisted by an electric current, on alloys. The relation of the composition of the dissolved and undissolved portions depends on a number of factors, and there is no reason whatever to suppose that the residue after attack consists of a pure inter-metallic compound. Even if proved to be homogeneous by physical tests, it may be a solid solution in equilibrium with the reagent under the given conditions. Rather more weight may be attached to the results if the attack by several different reagents—acids and alkalis, for example—yields residues of identical composition, but this is rarely the case.

An inter-metallic compound is not necessarily less acted on by reagents than the more reactive of its component metals, although this is true of many compounds. Guertler enumerates the following compounds which are more readily tarnished by moist air, or acted on by dilute acids, than either of their components: PbTl_2 , Bi_5Tl_3 , NaPb , Na_3Bi , Na_3Sb , Mg_2Pb , Mg_2Sn , Mg_3Tl_2 , Cu_3Si , Li_2Se , several compounds of calcium, and the compound of lead and platinum richest in lead, the formula of which is unknown.

Still less trustworthy is the method of pouring off the liquid portion of a partly solidified alloy, and treating the crystals with some reagent to remove adhering solidified

¹ *Metallurgie*, 1908, 5, 184, 621; compare E. Rudolff, *ibid.*, 257.

mother-liquor. A clean, glistening appearance of the solid thus obtained has often been accepted as proof of its chemical individuality, especially if the crystals exhibit some degree of stability towards reagents. Chemical literature is very rich in compounds described on such evidence alone. It is clear from a consideration of the equilibrium in alloys that a well-crystallized solid phase is by no means necessarily a chemical compound.

HEAT OF SOLUTION

The formation of alloys from their components may take place either with development or absorption of heat. The former case is observed in the combination of sodium with mercury to form the compound NaHg_2 , and the latter in the preparation of many fusible metals and amalgams. For example, Döbereiner observed in 1824,¹ that on mixing two amalgams of lead and bismuth at 16° , the temperature fell to -6.5° , whilst by mixing tin, lead, bismuth, and mercury a fall of 23° could be obtained, and he correctly pointed to the analogy with freezing-mixtures. Very few calorimetric estimations of the heat developed or absorbed have been made, although a few such are due to Person.² The direct estimation is only practicable in the case of metals which alloy at a low temperature, the calorimetric difficulties in other cases being almost insuperable. The possibility of other reactions contributing to the heat change must not be overlooked. Thus, when aluminium is added to molten copper, there is an immediate rise of temperature, often sufficing to raise the whole mass to an intense white heat, but this must not be attributed to the heat of combination of copper and aluminium, which is probably quite small, but to the reduction of the copper oxide, which is always present, by the aluminium, a strongly exothermic reaction. It is indeed very difficult to judge, by direct experiments alone, whether the heat change

¹ *Schweigg. J.*, 1824, 42, 182.

² *Ann. Physik.*, 1849, [ii] 76, 586.

accompanying the formation of an alloy is positive or negative, and the information must therefore be sought indirectly.

The indirect method of determining the heat of combination consists in measuring the heat developed when each alloy is dissolved in an appropriate reagent, and comparing the result with that calculated for a mixture of the same composition from the observed heats of solution of the component metals in the same solution. If the observed heat of solution is less than that calculated by the rule of mixtures, the difference is assumed to represent the heat developed in the formation of the alloy. This method, originally due to Hess,¹ has been employed by several investigators. The alloys of zinc and copper, in particular, have been examined repeatedly in this way. Dilute nitric acid was at first used as the solvent,² but it was shown³ that the gaseous nitrous products formed vary with the composition of the alloy, so that the reactions throughout the series are not comparable, and consequently no deduction can be made as to the heat of combination. A more extensive series of measurements, including alloys of other metals, was made by Herschkowitsch,⁴ who used a solution of bromine in potassium bromide as the solvent. The number of points on each of his curves is, however, too small to justify any conclusions. Very careful calorimetric measurements, using ferric ammonium chloride and cupric ammonium chloride as the solvents,⁵ indicate a maximum development of heat in the copper-zinc alloys at a composition corresponding with the formula CuZn_2 , the molecular heat of formation of which is found to be 10,143 cal.

The heat of formation of the carbides and silicides of iron

¹ See Ostwald's *Klassiker der exacten Wissenschaften*, No. 9, 1890.

² A. Galt, *Brit. Assoc. Rep.*, 1898, 246; 1899, 787; *Proc. Roy. Soc. Edin.*, 1898, 22, 137.

³ J. H. Gladstone, *Phil. Mag.*, 1900, [v.] 50, 231.

⁴ *Zeitsch. physikal. Chem.*, 1898, 27, 123.

⁵ T. J. Baker, *Phil. Trans.*, 1901, 196A, 529; see also W. F. Luginin and A. Schükareff, *Arch. Sci. phys. nat.*, 1902, [iv.] 13, 5; 1903, [iv.] 15, 49.

has been studied in the same way, by dissolving in cupric ammonium or potassium chloride.¹

Further experiments on these lines may lead to results of interest, but it is necessary that the calorimetric method adopted shall be of high accuracy, and that the reagent used shall be one of which the action is well known and uniform throughout the whole series studied.

¹ E. D. Campbell, *J. Iron Steel Inst.*, 1901, i. 211.

CHAPTER XIV

THE CONSTRUCTION OF THE EQUILIBRIUM DIAGRAM

THE complete equilibrium diagram of a series of alloys, having temperature and concentration as its co-ordinates, is composed of a number of lines and areas, the position of each of which is fixed by appropriate experimental means. The lines composing the diagram and bounding the areas of phase stability are, the vapour phase as usual being neglected—

1. The freezing-point curve, or liquidus ;
2. The solidus, which is also regarded, somewhat loosely, as the melting-point curve ;
3. Curves of liquid solubility, separating the regions of immiscible liquid phases ;
4. Horizontal or inclined lines, representing the transformation of solid phases, such as the polymorphic changes of crystals, the formation of compounds from solid constituents, and the separation of new phases from solid solution ;
5. Vertical lines, representing the limits of concentration between which the solid phases occurring in the system are stable in contact with each other. When the phases in question are not pure metals or compounds, but solid solutions, these dividing lines are slightly inclined, since the limits of saturation vary to a slight extent with the temperature. The variation is frequently negligible, and the lines may be regarded as vertical. When the variation is appreciable, the bounding lines are to be regarded as falling under class 4.

In the simplest cases, the positions of all the lines enumerated above may be fixed by a thermal and microscopical study of the alloys alone, although the possibility of changes which these methods fail to detect must not be overlooked. In more complex cases, ambiguities may arise in the interpretation of thermal and microscopical results unless the variations of other physical properties, such as specific volume, hardness, electrical conductivity, magnetic susceptibility and electromotive force are utilized to furnish auxiliary data. The results of such measurements may only serve to confirm conclusions already arrived at; but in other instances new light is thrown on the constitution of the alloys, and a metallographic investigation of any series of alloys cannot be regarded as complete unless its scope embraces the more important physical properties. Moreover, accurate data are urgently needed at the present time as a basis for generalizations as to the relations between the constitution of alloys and their physical properties. The establishment of such relations would have a high technical value, in making it possible to predict the character of new alloys and to determine the composition of the alloy most likely to present a certain required combination of properties. Furthermore, the question is one of fundamental importance for inorganic and physical chemistry. There are many theoretical problems on which light would be thrown by a thorough and systematic investigation of the properties of metallic alloys. The nature of the processes of solution, and of the attraction between solute and solvent, is apt to receive one-sided treatment when liquid solutions alone are considered, whilst no theory of valency or of chemical affinity can be admitted as satisfactory which does not take account of the remarkable relations exhibited by the inter-metallic compounds. The polymorphic changes undergone by solidified alloys afford a critical test of theories of crystalline structure and of the marshalling and rearrangement of closely packed assemblages, and attempts to explain the properties of solids by the application to them of a modified van der Waal's equation or of theories of internal pressure, must stand or fall by their applicability to alloys. The investigation of metals

and alloys subjected to mechanical strain has brought new elements unto the long-standing controversy as to the meaning of "solid" and "crystalline" states of matter, a controversy which received new life from the discovery of liquid crystals. Again, the nature of the molecular arrangements which give to magnetic bodies their remarkable properties must be considered in the light of the fact that non-magnetic metals are now known to form strongly magnetic combinations. Lastly, the nature of metastable and labile conditions and of false equilibria, and of their dependence on viscosity, is advantageously studied in metallic mixtures. The geologist, hampered by the high temperatures and enormous viscosities which present themselves in the experimental study of rocks, turns to alloys for information as to the processes which take place in the cooling of igneous magmas, and the changes in structure which are brought about by a departure from a condition of equilibrium. These instances of theoretical problems, in the solution of which the metallographer can render valuable aid, might be supplemented by many others.

The diagram considered has certain inevitable limitations. It is essentially an equilibrium diagram, that is, it represents the limits of temperature and composition within which each phase is, in the strict sense of the word, stable. But stability presupposes equilibrium conditions. An alloy may prove on examination to differ widely in properties from an ideal alloy having the same composition and the same temperature, but its condition is then not one of stability. The changes necessary to reach a state of stability may proceed so slowly, on account of the low velocity of diffusion, that the alloy may present a false appearance of being in equilibrium. Experiments continued over a long period may be required to determine the true equilibrium. Thus the alloys of lead and tin, frequently cited in the older text-books as a typical series composed of mutually insoluble solid metals, were found by later investigators to contain solid solutions of limited concentration; but baking for six weeks at a temperature only 2° below the eutectic point is necessary to enable the solid solutions, even in slowly cooled alloys, to attain their equilibrium

concentration.¹ The complete diagram having once been constructed, however, an inspection of it affords at least qualitative information as to the metastable and labile conditions which may be obtained, for instance, by rapid cooling. The prolongation of branches of the liquidus curve below the eutectic point indicates the effect of undercooling, and points to the abnormalities which may be expected in the micro-structure. The suppression of a transformation by rapid cooling through a certain range of temperature, causing the retention in the cooled alloys of a phase only stable at a higher temperature, is aimed at in all "quenching" processes, and a comparison of the microscopic structure with the diagram will indicate the extent to which the transformation has been suppressed. Such systematic quenchings, if sufficiently rapid, may be employed in the construction of the equilibrium diagram itself, as will be shown later.

After these general remarks, we may take the component curves and bounding lines of the diagram in order, enumerating in each instance the means which are at the disposal of the metallographist for fixing their positions.

1. *The Freezing-point Curve, or Liquidus.*—The construction of this curve is always based on the determination of the cooling curves of the individual alloys. "Direct" cooling curves (p. 123), preferably brought to a regular form by Plato's device, or the "inverse-rate" curves derived from them, are the most suitable for the purpose, as it is the initial freezing-point which is required. If undercooling takes place, the development of heat when freezing begins may be insufficient to raise the temperature of the mass to the true freezing-point, it is therefore necessary to guard against undercooling by inoculation with the solid phase. For this purpose, a preliminary cooling curve is taken, and the approximate freezing-point determined. A small portion of the solid alloy is reserved and reduced to powder, the remainder of the mass is then re-melted and the cooling curve taken. As the freezing-point is approached, particles of the solid are introduced, the mass being thoroughly stirred.

The thermo-couple used should be calibrated by taking the

¹ W. Rosenhain and P. A. Tucker, *Phil. Trans.*, 1908, 209A, 89.

freezing-points of a number of pure metals, using the same apparatus as in the investigation. Small errors due to a lag of temperature between the thermo-couple and the alloy are eliminated in this way; large errors should not occur if the tube protecting the couple is of small diameter and the rate of cooling is sufficiently low. This calibration by means of pure metals, using the standard freezing-points given on p. 114, affords a ready means of reducing all readings of temperature to those of the air thermometer. The reduction should always be performed, the publication of thermal diagrams referred to more or less arbitrary standard temperatures, a too frequent practice, being very misleading.

It is of great interest to determine, with a high degree of accuracy, the initial portions of a freezing-point curve, as was done by Heycock and Neville for a large number of metals, the pyrometer used by them being of the very sensitive platinum resistance type. By taking a sufficient number of points at a short distance apart, the atomic depression may be determined, and the validity of Raoult's law tested. Information is thus gained as to the molecular condition of the dissolved metal (see p. 329) Similar closely-grouped determinations in the neighbourhood of maxima in the liquidus also present a certain interest as a means of estimating the degree of dissociation of an inter-metallic compound into its components on melting. Alloys have not yet been studied from this point of view, but the researches of Kremann on mixtures of organic substances indicate that interesting results may be expected, especially if a comparison be made with ternary systems.

Should the freezing-point curve be horizontal for a part of its course, the existence of two liquid phases may be suspected, and one should proceed as under section 3 below.

The most difficult part of a freezing-point curve to determine is a branch ascending very rapidly from a eutectic point. Such branches are most likely to occur in systems in which the eutectic composition lies very close to one of the component metals. This is the case, for instance, in the alloys of copper and bismuth, the eutectic mixture of which is practically indistinguishable from pure bismuth. The curve representing the

crystallization of pure copper rises very rapidly at first—to the extent of 400° for 20 atomic per cent. Cu.¹ The initial freezing-point of an alloy falling within this range is marked by only a very indistinct arrest on the cooling curve, since the quantity of copper deposited is very small. The use of large quantities of the alloy, a slow rate of cooling, a sensitive galvanometer, and the plotting of the results in the form of “inverse-rate” curves, are to be recommended in such cases.

The freezing-point surface of a ternary system is constructed by grouping the results of the thermal study so as to form a series of binary systems, or vertical sections through the space-model (p. 76).

It is often recommended that the determination of the cooling curve should be supplemented by that of the heating curve. Whilst this undoubtedly gives valuable results in the study of polymorphic change, it is of far less value for the construction of the liquidus. The initial freezing-point on cooling corresponds with the disappearance of the last solid particles on heating, a point which it is difficult to determine with the requisite accuracy.

The liquidus represents the limit of existence of solid phases. All points lying above it denote completely liquid alloys, assuming that the temperature is not raised above the boiling-point of one of the components. Each point on the liquidus gives the highest temperature at which a solid phase can exist in an alloy of that composition. All points below the liquidus denote alloys in which, under conditions of equilibrium, at least one solid phase is present.

It is sometimes impossible to complete the liquidus of a series of alloys, on account of the volatility of one of the components at temperatures approaching the melting-point of the other component. An investigation of the alloys of iron and zinc, for instance, is necessarily limited, under ordinary conditions, to the alloys ranging from pure zinc to a mixture containing a small percentage of iron; richer alloys lose zinc before melting. The alloys of arsenic with the less fusible metals, on the other hand, can only be investigated at the end of the

¹ K. Jeriomin, *Zeitsch. anorg. Chem.*, 1907, **55**, 412.

series corresponding with the higher temperatures, the alloys containing small proportions of arsenic being stable, in spite of their high melting-point, whilst those rich in arsenic lose the excess of this element when melted under atmospheric pressure. It is possible, when the general aspect of the diagram is known, to construct the portion inaccessible to direct experiment by extrapolation from a ternary diagram. This device, which has been applied in a single instance, may prove of value in other researches into similar systems. The alloys of zinc and nickel can be examined under ordinary pressure up to 54 per cent. of nickel, beyond which the melting-point is so high that zinc is lost by volatilization. The ternary system copper-zinc-nickel has been investigated, and the increase of fusibility due to the copper makes it possible to determine the freezing-points of almost the whole series of ternary alloys.¹ The general course of the liquidus and solidus has been determined as far as the volatility of the zinc allows, and extrapolation of the surfaces obtained gives the missing portion of the diagram of the binary system nickel-zinc without serious risk of error.

2. *The Solidus.*—The construction of the solidus, dividing those regions in which only solid phases are present from those in which liquid is still present, presents much greater difficulties, both experimental and of interpretation, than that of the liquidus. The solidus is made up, in the majority of cases, of a number of separate portions—horizontal, vertical, and inclined. Taking the simplest case first, that of a eutectiferous series in which the only solid phases are the pure components (Fig. 4), the only line which falls to be determined is the eutectic horizontal. The points on this line are given by the lower arrests on the cooling curves. With sufficiently accurate experimental methods, all of these arrests should occur at the same temperature, although small deviations are liable to occur as the ends of the horizontal are approached, that is, as the quantity of eutectic diminishes. A steady fall of the eutectic line in one direction points to experimental inaccuracy.² The

¹ V. E. Tafel, *Metallurgie*, 1908, 5, 343, 375, 413.

² See, for instance, P. Dejean, *Rev. de Métallurgie*, 1906, 3, 233, T.P.C.

determinations nearest to the eutectic point, where the arrest is most strongly marked, are likely to be the most accurate, and should be chiefly trusted in fixing the position of the horizontal.

Undercooling at the eutectic point is a source of considerable difficulty. A pure eutectic mixture, like a pure metal, may be undercooled, and the addition of both solid phases simultaneously is necessary to prevent the undercooling. This is effected by the device of adding a portion of the previously cooled and powdered alloy; but when the eutectic forms only a small part of the alloy, this precaution is difficult to apply. When one phase is in excess, it may continue to separate after the eutectic temperature has been passed, the remaining constituent continuing as an undercooled liquid. The final solidification of the latter is marked by a rise of temperature, by which the fact of the undercooling is rendered visible on the cooling curve, although its extent remains doubtful. The difficulty of resorting to inoculation is due to the fact that the liquid eutectic is distributed throughout a mass of the solid excess constituent, and is not readily brought into contact with the substance used for inoculation, although this may be partly remedied by thorough stirring. The existence of eutectic undercooling may sometimes be detected by the two branches of the freezing-point curve appearing to intersect at a point somewhat above the horizontal drawn in the preliminary diagram.

In cases of this kind a useful check is afforded by the examination of heating curves. When the eutectic temperature is reached in heating, a portion of the alloy melts; and this takes place without superheating, provided that segregation has not been so excessive as to prevent intimate contact of the solid phases. If segregation has taken place, the apparent eutectic point is too high (p. 29). The correct temperature may be obtained by taking a heating curve after reducing the alloy to a fine state of division.

The temperature of the eutectic horizontal having been fixed, it remains to determine the limits of composition to where the rise of the copper-copper oxide eutectic line is certainly due to an error, probably occasioned by considerable undercooling.

which it extends in each direction. The component metals are generally capable of retaining a certain quantity of the other component in a state of solid solution, and in such a case the eutectic line must stop short of the limits of the diagram. Microscopical examination is a more sensitive method of fixing these limits than thermal analysis. Should a slowly cooled alloy of A and B, containing, for example, 0.1 per cent. of the metal B, show under the microscope distinct traces of inter-crystalline matter, we may conclude that the solubility of B in solid A does not exceed 0.1 per cent. The application of this method has often failed from the difficulty experienced in many cases of preparing a sufficiently good surface for so minute a quantity of a micrographic constituent to become visible. This is purely an experimental difficulty, and is certainly not insurmountable. With the necessary experimental skill, and by the use of suitable polishing methods, especially when dealing with soft metals such as lead, it is undoubtedly possible to detect very minute traces of included inter-crystalline matter. Heat-tinting or exposure to vapour is to be preferred for this purpose to etching with acids, since the latter treatment results in the production of grooves between the crystal grains, masking the feature sought for. The included metal B is more likely to appear as a film or band than to show a eutectic structure, on account of the tendency of eutectics, already noted, to undergo segregation in presence of a large excess of one of their component phases.

The second method of fixing the limits of the eutectic horizontal is that due to Tammann, consisting in plotting the duration of the eutectic arrest in each alloy of the series against the composition. It has the advantage that should the arrest become indistinguishable in the extreme members of the series, the limits of the horizontal may be estimated by extrapolation. The trustworthiness of this method has been keenly debated,¹ but an examination of the results obtained by it leads on the whole to the conclusion that the method is unexceptionable if applied with proper experimental precautions, the chief

¹ See a discussion on papers by W. Rosenhain and by C. H. Desch, in *J. Inst. Metals*, 1909, i. 240.

requisites being a pyrometric method of high sensitiveness and the employment of comparatively large quantities of material. The excellent results obtained in the laboratory of Friedrich, of Freiburg, by the application of this method, are strongly in its favour, and the criticisms which have been raised against it are due rather to hurried publications by insufficiently skilled observers, based on work with small quantities of impure material, than to defects inherent in the method itself.

In applying the method of eutectic times, it is necessary to ensure that all the alloys of the eutectiferous series are examined under comparable conditions. The quantities of component metals should be so chosen that the molten alloys occupy equal volumes, it being advisable to determine this by a preliminary experiment. If very different volumes of the successive alloys of a series are taken, the correction of the arrest-times by calculation for equal volumes is unsatisfactory, on account of the uncertainty introduced into the cooling conditions.

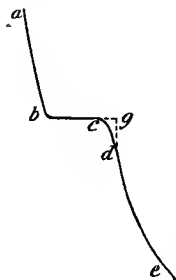

FIG. 96.
Correction of cooling
curve.

The cooling curve usually presents a slight rounding of the horizontal portions, and it is therefore necessary to determine what are the limits of time between which the arrest is to be assumed to continue. This may be done with a satisfactory degree of accuracy by producing the horizontal line *bc* (Fig. 96) and the descending line *de* until they meet at *g*. The distance *bg*, measured on the time scale, may be taken as the duration of the arrest.

When the arrest-times are plotted against their respective compositions, the curve joining the points thus obtained should consist of two straight lines, meeting at the composition of the eutectic mixture, and intersecting the axis of time at the compositions at which the last trace of eutectic disappears. Such a condition is shown in Figs. 4 and 7. If the eutectic composition practically coincides with one of the pure metals, the curve consists of only one such line. Sometimes the line,

or lines, instead of being straight, are markedly curved, the concavity being usually directed downwards, towards the composition axis. Tammann suggests that the eutectic limits may still be found in such a case by extrapolation, but the uncertainty of such a procedure is obvious, since the curve tends to flatten as it approaches the axis, and little weight can be attached to limits calculated in this fashion. The deviations from a straight line are probably due to variations in the specific heat from one alloy to another, and they should therefore disappear wholly or largely from curves taken by Plato's method. Limits found by extrapolation should only be employed in the construction of an equilibrium diagram when the lines produced are sensibly straight. A detailed example of the application of the method is given below (p. 320).

In addition to eutectic lines, the solidus may comprise lines corresponding with chemical reactions between solid and liquid, such as the line at 460° in the diagram of the antimony-gold alloys (Fig. 13, p. 40), which indicates the chemical reaction

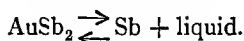

Such a reaction, occurring during cooling, takes place in the direction of the lower arrow with development of heat, and is consequently marked by an arrest on the cooling curve, an arrest which is very liable to be affected by under-cooling. The treatment of the arrest times follows that described above in connection with eutectics. The crystallization time is a maximum at the formula corresponding with the compound formed on cooling. The reaction is liable to be incomplete, owing to the fact that one of the reacting bodies is solid, the product being also solid. A reaction therefore takes place on the outer surface of the crystals, a layer of the new compound being formed, but the presence of this layer checks further chemical action, by isolating the interior of the crystals from the liquid with which they have to react. Unless sufficient time is allowed for the composition of the particles to become uniform through diffusion, the process is arrested at an incomplete stage. When this is the case, the maximum development

of heat due to the reaction is not observed at the composition of the compound, but at the composition of an alloy containing a larger quantity of the more fusible metal, as the thermal effect is the same as if a part of the original crystals had been withdrawn from the mass. Evidently, the error due to this cause will be lessened by thorough stirring, which favours the formation of very small crystals, presenting a larger surface in proportion to their mass, and therefore allowing the reaction to proceed further towards completion. The plan of causing cooling to proceed so slowly that diffusion has time to equalize the composition of the solid particles is impracticable on account of the slowness of the process. We may also, after cooling the alloy, crush it to a fine powder to facilitate contact of the reacting substances, and re-heat to the transformation temperature, taking a new cooling curve from that point.¹ Eutectic arrests occurring at lower temperatures, which are displaced as to duration by the error described, assume their correct values after this treatment.

Turning to alloys in which solid solutions are formed, the determination of the exact position of the solidus now assumes greater difficulty. Consider first a pair of isomorphous metals, such as gold and silver. The solidus may be considered from two points of view. On the one hand, it represents the temperatures at which solidification is completed; on the other, it represents the composition of the solid phase in equilibrium with the liquid at each temperature. An experimental determination by the latter method is impracticable, for although means have been devised for isolating and analysing solid phases during crystallization,² it is impossible to free the crystals from mother-liquor, and the accuracy obtainable is quite insufficient for the purpose. The thermal method is therefore the only one available. Its uncertainty arises from

¹ G. Tammann, *Zeitsch. anorg. Chem.*, 1905, **45**, 24. An instance occurs in the alloys of gold and lead at the point of formation of Au_2Pb . R. Vogel, *ibid.*, 1905, **45**, 11.

² C. van Eyk, *Proc. k. Akad. Wetensch. Amsterdam*, 1902, **10**, 859. A device for estimating the proportion of mother-liquor retained is described by A. van Biljert, *Zeitsch. physikal. Chem.*, 1891, **8**, 343; and W. D. Bancroft, *J. Physical Chem.*, 1902, **6**, 178.

the fact that the point c on the cooling curve (Fig. 17), at which the development of heat ceases and the curve joins that of the cooling solid, is marked by only a slight change of curvature, so that its position is not readily determined. The more sensitive the instruments used, and the more nearly the directions of ab and cd approach to a straight line, the more distinct becomes the change of curvature. The position of the solidus in all such diagrams, however, should be accepted with considerable reserve. A further error, due to imperfect readjustment of equilibrium between crystals and liquid during solidification, has already been described.

An ingenious method of fixing the position of the solidus, different in principle from those described, was introduced by Heycock and Neville in their investigation of the copper-tin alloys.¹ It consists in quenching several alloys of the same composition from different, exactly determined temperatures, lying a short distance below the initial freezing-point. One of these alloys, let us suppose, is quenched before it is completely solid, and on microscopical examination it is easy to detect the suddenly chilled mother-liquor as an inter-crystalline material, filling the cavities between the crystals which separated during the slow cooling. Another alloy, quenched just after solidification was complete, is found to consist wholly of the solid solution. The point on the solidus corresponding with this alloy evidently lies between the quenching temperatures of these two alloys, and by a suitable choice of temperatures the solidus may be drawn with great accuracy if adequate means of rapid quenching are available and a sufficient number of alloys are examined. The method has been little followed by later workers, although it is unassailable. It has recently been used with success in fixing the position of the solidus in the iron-carbon series, thermal methods having failed to give a sufficiently exact result.²

It has been said that the solidus may also be regarded as

¹ *Phil. Trans.*, 1903, 202A, 1.

² N. Gutowsky, *Metallurgie*, 1909, 6, 731, 737. The same method has been employed in a very careful study of the ternary alloys of copper, tin, and aluminium, C. A. Edwards and J. H. Andrew, *J. Inst. Metals*, 1910, 2, 29.

the melting-point curve, since it represents the temperatures at which the first appearance of a liquid phase takes place when the alloys of the series are heated. The exact determination of the first appearance of liquid is a matter of difficulty. The thermo-couple, being in contact only with the solid alloy, does not respond readily to the small change in the rate of heating which marks the melting of the most fusible constituent, and the equalization of temperature throughout the mass by stirring is impossible. As a rough preliminary determination of the solidus, especially in the case of alloys fusing at a moderate temperature, the method of heating the alloy in a furnace of uniform temperature may be adopted, the first appearance of "sweating" on the surface of the alloy being noted. The temperature thus observed is above the true value, but a series of such observations may be of value in indicating the existence of a compound in the series, an abrupt change in the temperature at which liquid appears occurring when the composition of the compound is passed. Such a curve has been used with success in the investigation of mixtures of non-metals, under the name of the "sintering-point curve."¹

The dilatometric method may also be employed to fix the position of the solidus in the case of alloys which can be heated in a volume-dilatometer. This method is therefore most suitable for alloys of low melting-point. It has been applied to the cadmium amalgams,² the volume changes of which on melting are considerable.

3. *Curves of Liquid Solubility.*—The separation of an alloy into two liquid phases, or the failure of two metals when melted together to form a homogeneous liquid, introduces an important modification into the thermal and microscopical results. Should such a separation be suspected, the mixture is allowed sufficient time for the separation into two layers to take place, and is then allowed to cool and examined microscopically. The difference between the upper and lower parts of the ingot, supposing separation to have taken place, is usually obvious. It may happen, however, that the two

¹ A. Stock, *Ber.*, 1909, **42**, 2059, 2062.

² H. C. Bijl, *Zeitsch. physikal. Chem.*, 1902, **41**, 641.

liquids form an emulsion which separates with difficulty, the less fusible alloy then solidifies as a spongy or honeycomb-like mass, in the meshes of which the still liquid constituent is held. This may be detected microscopically, or even by visual examination without magnification. The drops or globules of the more fusible constituent are not liable to be mistaken for the crystals which separate from a homogeneous liquid. The mixture may be very intimate, as in some alloys of copper, tin, and lead used as bearing-metals,¹ but their character of emulsions is unmistakable.

If any portion of the freezing-point curve has been found to have a horizontal direction, the formation of two liquid layers may be suspected. A short horizontal branch may also exist in the case of a compound completely dissociated at its melting-point under exceptional conditions,² but the case is unlikely to present itself in alloys. Mixtures having a composition falling between the limits of the horizontal portion are therefore submitted to microscopical examination.

The maximum duration of the corresponding arrest occurs at the point E (Fig. 37), the arrest being due to the crystallization of the metal B from the liquid phase E. The quantity of this phase which is produced is a maximum at E. The development of heat due to separation into two liquid phases is in general very small, and the cooling of an alloy will therefore not undergo a marked arrest on crossing the curve *DdeE*.

The upper parts of the liquid solubility curve, lying above its intersection with the liquidus, are without importance as regards the constitution of the solidified alloys, but have a physico-chemical interest of their own. Methods which involve rapid cooling of the liquid and mechanical separation of the solidified layers are unsatisfactory, and any attempts to determine the course of the curve, and to fix the temperature of the critical point, must involve the separation of the layers while still liquid by suitable pipetting or tapping.³

¹ G. H. Clamer, *J. Franklin Inst.*, 1903, 156, 49.

² Such a curve has been observed in mixtures of naphthalene with *m*-dinitrobenzene. R. Kremann, *Monatsh.*, 1904, 25, 1271.

³ See p. 90.

4. *Transformations of Solid Phases.*—The horizontal lines representing polymorphic changes in solid phases may or may not intersect the liquidus. In the former case, a change takes place at a certain temperature in the nature of the solid phase in equilibrium with the liquid, and this involves a discontinuity of direction in the liquidus curve. The effect on the liquidus is therefore the same as that produced by a compound decomposing below its melting-point, and it becomes necessary to find a means of distinguishing between these two possibilities. Such a case is illustrated in Fig. 97. The ascending

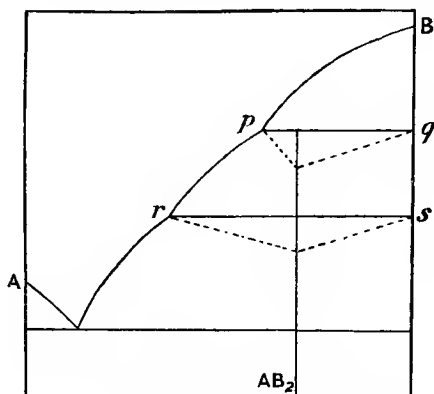

FIG. 97.—Compounds and polymorphic changes.

branch of the freezing-point curve presents two similar discontinuities, at r and p respectively, and alloys lying within the respective limits of concentration have arrests on their cooling curves, represented by the lines pq and rs . So far, the thermal examination does not indicate whether compounds are formed on cooling or not. The application of Tammann's method, however, makes the distinction possible. If we compare the duration of the arrests and construct arrest-curves, we obtain such results as are shown in the figure. The arrest pq has a maximum duration in the alloy containing 66.7 atomic per cent. of B, indicating the formation of a compound AB_2 .

The development of heat due to its formation is obviously greatest in the alloy, the whole of which is converted on cooling into the compound AB_2 , and falls off in mixtures containing an excess of either A or B over that composition. Had the arrest pq been due to a polymorphic change of B, its duration would have increased from p onwards, being greatest in the cooling curve of the pure metal B.

The arrest rs is represented as having its maximum duration at the same composition, indicating that it is due to a polymorphic change in the solid compound AB_2 . Had it been due to a reaction between AB_2 and the liquid forming a second compound, say AB, its maximum would have occurred at a different composition—in the case last assumed at 50 atomic per cent. Only one of the many possibilities is represented in the figure, but the application of the method to other cases is easy.

A polymorphic change occurring below the solidus may be represented by a horizontal or by an inclined line. If by the former, that is if it occurs at the same temperature throughout its whole range, the substance undergoing the change, whether element or compound, occurs in all the alloys in a free state, and not as a solid solution. The maximum duration of the arrest occurs at the composition of the constituent which undergoes change. The arrest at rs (Fig. 97) is of this kind.

An inclined line may represent a polymorphic change in a solid solution, since the presence of a dissolved substance in a solid alters transformation temperatures as the presence of a dissolved substance in a liquid alters freezing temperatures. Instances have been given in Chapter III. The method of arrest-times is inapplicable to changes which take place at temperatures varying with the composition, the temperatures at which the arrests take place are therefore plotted on the diagram, and other means must be adopted to determine the nature of the constituent undergoing change.

Polymorphic changes during cooling are very liable to be masked by undercooling, as the high viscosity of the solid hinders molecular rearrangement, and the new phase, which is

necessary to initiate change in the metastable region, is not present when the transformation temperature is reached. We are as yet ignorant of the interval which separates the metastable limit from the transformation temperature in solids. This limit once passed, and the labile region entered, the presence of the new phase is not necessary to initiate the change, but the viscosity is such that if only a short time is allowed for cooling through the critical range, the transformation may be wholly or partly suppressed.

It has been urged¹ that transformations in the solid state should be investigated by means of heating curves rather than of cooling curves, on the ground that the transformation point is more readily overstepped in descending than in ascending. Actually, overheating does occur to some extent, and the readings obtained from heating curves are liable to give high values for the transformation temperatures. Both heating and cooling curves should be taken in accurate work; if they indicate transformations at the same temperatures, their indications are certainly trustworthy; should there be a small difference in the observations, the mean of the ascending and descending readings may be taken. An alloy to be examined for polymorphic changes should be first cooled as rapidly as possible to ensure a fine crystallization, and then reheated to the temperature of transformation.

The thermal method does not necessarily record every transformation which takes place, as it is possible for a polymorphic change to occur with very little change in the energy-content of the system. In such a case, however, there must be a change of volume, and the transformation may therefore be detected dilatometrically, as described in Chapter XII.

The important class of polymorphic changes which are marked by an alteration in the magnetic properties are investigated by the methods described in Chapter XII. If the magnetic change is found to occur at the same temperature throughout a series of alloys, it is evidence that the magnetic metal is present throughout the entire series in the free state.

¹ B. E. Curry, *J. Physical Chem.*, 1907, 11, 425.

This is the case with the alloys of gold and nickel,¹ the temperature at which nickel becomes non-magnetic being unaltered by alloying with gold.

On the other hand, in a series of solid solutions, the magnetic change takes place at temperatures varying with the composition, as in the alloys of cobalt and nickel,² the magnetic transformation curve of which resembles the liquidus, although having a different slope.

The assistance of the microscope in determining transformation points is essential, whether these have been recorded as the results of thermal, dilatometric, or magnetic observations. It is possible for a constituent to undergo polymorphic change without any change being produced in the micro-structure, but such cases are exceptional, and are probably often due to the insufficiency of our means of developing structure. The occurrence of magnetic change, for instance, must, on our present assumptions as to the molecular constitution of solids, be accompanied by some alteration in the ultimate arrangement of the molecules, which it should be possible to detect by suitably delicate means. The exact observation of the form and orientation of the minute etching-pits produced by the action of reagents may render it possible to distinguish crystalline arrangements which appear identical under the comparatively coarse etching treatment to which the crystals are commonly subjected. There is much room for progress in this direction, the etching of apparently homogeneous structural constituents having by no means received the attention it deserves.³

The procedure in seeking for transformations by the microscopical method consists in quenching specimens of each alloy from several known temperatures, with the object of preserving in a metastable or labile state, the phase or phases constituting the alloy at the quenching temperature. If cooling curves of the alloys have been taken previously,

¹ M. Levin, *Zeitsch. anorg. Chem.*, 1905, **45**, 238.

² W. Guertler and G. Tammann, *ibid.*, 1904, **42**, 353.

³ See F. Osmond and G. Cartaud, on the crystallography of iron, *J. Iron Steel Inst.*, 1906, iii. 444.

these afford guidance as to the most suitable temperatures from which to quench the specimens; in the absence of any knowledge as to the existence or position of thermal arrests, the proper temperatures must be found by trial. The earliest and most important investigation of this kind, the study of the copper-tin alloys by Heycock and Neville, already referred to more than once, was carried out entirely by the microscopical

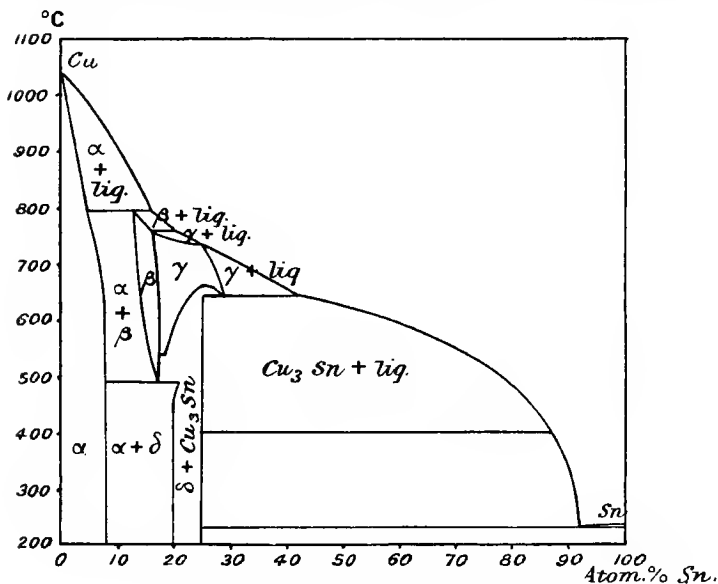

FIG. 98.—Incomplete diagram of copper and tin.

examination of quenched specimens, without the aid of pyrometric observations of transformation arrests. The diagram, modified in some minor details by later work,¹ is represented in Fig. 98. It is not complete, the discrepancies between the different observers being too great to permit the complete demarcation of certain regions, notably that lying below the γ region. A few examples will make the method clear. A

¹ E. S. Shepherd and E. Blough, *J. Physical Chem.*, 1906, 10, 630; F. Giolitti and G. Tavanti, *Gazzetta*, 1908, 38, ii. 209.

certain number of specimens are allowed to cool from their freezing-point to the ordinary temperature at a very slow rate, even 24 hours being allowed for the cooling of a specimen weighing 5-10 grams. These alloys, examined microscopically, are taken to represent mixtures in equilibrium. Other alloys, having the same compositions, are cooled very slowly down to a certain prearranged temperature, and are then quenched as rapidly as possible.

The diagram is complicated, and observers differ as to the exact changes taking place in alloys containing between 15 and 30 atomic per cent. Sn. In constructing the diagram, most weight has been given to the quenching results of Heycock and Neville, the boundaries of the respective fields as determined by them being only altered when inconsistent with equilibrium or when decisively shown to require modification. Both the later researches mentioned were also conducted with great care.

An alloy containing 9 atomic per cent. Sn, quenched at 700° , consists of primary crystals of α , surrounded by β . The β constituent is unstable below 480° , and a specimen cooled slowly to 470° and then quenched, shows the α crystals surrounded by a eutectoid mass of α and δ , produced by the breaking up of β .

5. *Vertical Lines.*—The limits of composition within which the respective solid phases exist are represented by lines which are vertical when we are dealing with pure components, but more or less inclined when the phases consist of solid solutions. The latter case has been considered, so far as lines of considerable inclination are concerned, in the last section. From a practical point of view, the boundaries at atmospheric temperatures—that is, the points at which the vertical or inclined lines cut the base of the diagram—are of the greatest interest, as they indicate the nature of the phases constituting an alloy of a given composition when cold. Three methods are available for fixing these limits, namely, (a) thermal analysis, (b) microscopical examination, (c) the observation of discontinuities in physical properties.

It has already been shown how the observation of the

composition at which an arrest due to a chemical reaction between crystals and mother-liquor, to the solidification of a eutectic, or to the transformation of a solid phase disappears, may be used to determine the limits of existence of a phase at the temperature in question. The application of Tammann's method in a complex case may be illustrated by an imaginary example, in which round numbers are used for the sake of convenience.¹ The equilibrium diagram is represented in Fig. 99.

The freezing-point curve ABCDEFG, presents two eutectic minima at B and E, a well-marked maximum at D, and breaks on ascending branches at C and F. The points representing the end of solidification have been entered on the diagram, and form the broken solidus curve, MBNPQRESTUG. The duration of each arrest on the cooling curves has also been recorded, and is plotted on the same diagram; the time composition curves being dotted and inverted to avoid overlapping. For example, alloys containing from 0 to 40 atomic per cent. of the metal Z, show an arrest at 400°, due to solidification of the eutectic. The duration of this arrest increases with the proportion of Z up to 22 per cent., and then decreases. The arrest times form the curve, M δ N, becoming zero at N. The curves, C ρ Q, R ϵ S, and F ι U are obtained in the same way.

The evidence for the existence of a compound at the point D is as follows:—

1. An alloy containing 50 atomic per cent. of the metal Z freezes completely at 750°, the temperature remaining constant until the whole is solid.

2. The development of heat at 500°, observed in alloys containing 35 to 50 atomic per cent. Z, disappears at the latter composition, as indicated by the curve C ρ Q.

3. The eutectic arrest at 600°, observed in alloys containing 50 to 75 atomic per cent., also becomes zero at the same composition, as indicated by the line R ϵ S.

4. The diagram also indicates an arrest at 300°, observed

¹ This example is taken from the author's paper in *J. Inst. Metals*, 1909, i. 227.

in alloys containing 40 to 75 atomic per cent. Z. This is due to a polymorphic change in the solid state, the β modification stable at high temperatures passing into an α modification on cooling past 300° . The maximum development of heat due

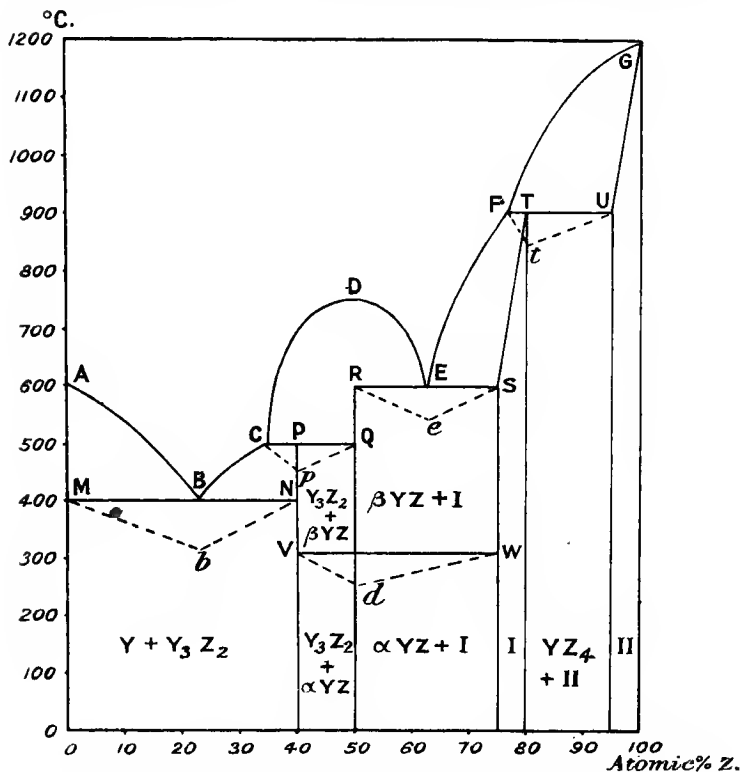

FIG. 99.—Application of Tammann's method to a complex system.

to this cause is found at 50 atomic per cent., as indicated by the curve VdW .

All these facts point to the existence of a compound having the formula YZ .

The diagram indicates the presence of two other compounds, causing breaks in the freezing-point curve at C and F,

but not giving rise to maxima as at D. To take the point C first:—

1. The arrest at 500° (curve $C\beta Q$) reaches a maximum at 40 atomic per cent. Z. The arrest is due to the reaction of the crystals of the compound YZ, which have separated at higher temperatures, with a part of the still liquid alloy.

2. The eutectic arrest at 400° (curve $M\beta N$) and the transformation arrest at 300° (curve $V\alpha W$), reach zero at the same composition, on the line PNV.

These facts point to the existence of a compound of the formula Y_3Z_2 .

It will be seen that the composition of the compound could not have been obtained by an inspection of the freezing-point curve alone. The break at C does not coincide with its composition, but occurs earlier, at 35 atomic per cent. This approaches more nearly to the formula Y_2Z . The absence of any determinations of the time of arrest prior to Tammann's researches is the cause of many of the erroneous formulæ for inter-metallic compounds found in the literature.¹

Similarly, the point F represents the formation of a third compound from crystals and fluid alloy. The maximum time of reaction is found by the curve $F\gamma U$ to occur at 80 atomic per cent. Z, corresponding with the formula YZ_4 . The time curves $R\epsilon S$ and $V\alpha W$, however, do not extend to 80 atomic per cent. Z, but reach zero at a lower concentration, namely, 75 per cent. This indicates that the compound YZ is capable of forming solid solutions (mixed crystals), with an additional 5 per cent. of Y. In the same way, the form of the curve, $F\gamma U$, points to the retention of as much as 5 atomic per cent. of Y by the metal Z in a state of solid solution.

The imaginary diagram, constructed for the sake of round numbers, thus demonstrates the existence of three compounds of Y and Z, namely, Y_3Z_2 , YZ, and YZ_4 , of which only the second can be melted without decomposition, the first and third decomposing below their melting-points into a liquid alloy and crystals of YZ, and of a saturated solid solution of

¹ The physical methods described in Chapter XII. provide further means of determining the composition of intermetallic compounds.

Y and Z respectively. The compound YZ exists in an α and a β modification, having a transition point at 300° . The interpretation of any real diagram is based on exactly the same principles.

Whether the limits of existence of the solid phases at atmospheric temperature correspond with those determined at higher temperatures is best ascertained microscopically. Referring again to the diagram (Fig. 99), we see that slowly cooled alloys containing 0-40 per cent. Z consist of two solid phases, namely, Y and Y_3Z_2 . Between 40 and 50 per cent., they consist of Y_3Z_2 and the α modification of YZ. From 50 to 75 per cent., the solid phases are α YZ, and the solid solution I, containing 75 atomic per cent. Z. Alloys of 75-80 per cent. Z are homogeneous, consisting only of the solid solution I, which changes progressively in composition within these two limits. From 80 to 95 per cent. there are again two phases, the compound YZ_4 , which is the limiting member of the series of solid solutions I, and the saturated solid solution II, containing 95 per cent. Z. Lastly, alloys containing 95-100 per cent. Z consist again of a single solid solution, II.

For micrographic purposes, we may subdivide this series somewhat further by considering the eutectic as a separate constituent. Although a complex of two phases, the structure of the eutectic is such as to give it a distinct microscopical individuality. Under a low magnification, it may appear to be homogeneous; and even when its heterogeneous character is evident, it is clearly distinguished from the crystals of the phase in excess. We may therefore break up the region between 0 and 40 per cent. Z into two parts, one extending to 22 per cent. Z, in which crystals of Y are associated with the eutectic, and one from 22 to 40 per cent., in which crystals of Y_3Z_2 and the eutectic occur together. The region from 50 to 75 per cent. Z is similarly divided at 62.5 per cent.

The structure of alloys in a state of equilibrium is most conveniently represented by a diagram of the kind devised by Sauveur.¹ Such a diagram, constructed for the series in

¹ See p. 28.

question, is shown in Fig. 100. The relative volume of each constituent in a given alloy, and, consequently, the relative areas exposed in a representative section, are easily read off from such a diagram. The only alloys which can present a homogeneous structure are those containing exactly 40 per cent. or 50 per cent. Z, and those containing between 75 and 80 per cent. or between 95 and 100 per cent. Z. In addition to these, the two alloys containing 22 and 62.5 per cent. Z respectively present only a single micrographic constituent, a binary eutectic. The structure of any other alloy of the series may be ascertained from the diagram by following the ordinate corresponding with its composition upwards until a diagonal line is intersected. A horizontal line drawn through the intersection gives, on the vertical scale, the relative areas of the two constituents whose fields meet along that diagonal.

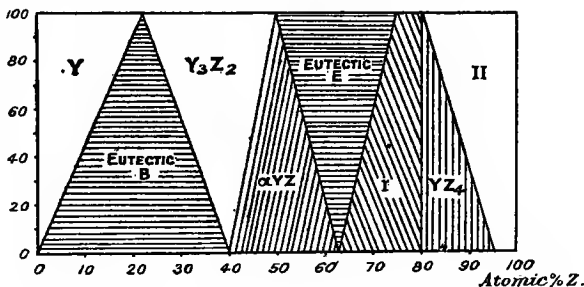

FIG. 100.

The proportions may be checked by planimetric measurements of the alloys, and, conversely, the constitutional diagram being known, planimetric measurements may be employed as a means of analysis, a horizontal line being drawn through the proportion of the two constituents found, and a perpendicular dropped from its intersection with the corresponding diagonal on to the axis of composition. Planimetric analysis has been used as a means of estimating the carbon in soft steels,¹ and the oxygen in copper,² and has been further extended to a

¹ A. Sauveur, *Metallographist*, 1898, 1, 27.

² H. O. Hofmann, C. F. Green, and R. B. Yerxa, *Trans. Amer. Inst. Min. Eng.*, 1904, 34, 671.

number of copper alloys.¹ For the practical application of the method, the image of the section, the structure having been suitably developed, is projected on to a screen, and the outlines are traced with a pencil. A border is then ruled, and the area of one constituent measured with the planimeter and compared with the whole area enclosed within the border. If the outlines are very intricate, the planimeter becomes untrustworthy, and better results are obtained by ruling lines, dividing the whole surface into squares 1×1 cm., shading the areas of one of the constituents, and estimating the relative proportions shaded and unshaded in each square—an operation which is soon accomplished with considerable accuracy. A projection is to be preferred to a photo-micrograph, on account of the larger scale, and also because the elimination of unnecessary detail makes it easier to follow the outlines.

If the section consists of primary crystals with a small quantity of eutectic, the area of the latter is liable to be much less than that indicated by the diagram, owing to the attraction of the large crystals for the particles of similar nature in the eutectic. In an examination of phosphor-coppers containing less than the eutectic proportion of Cu_3P , it was observed that the area of the copper crystals was always greater than that calculated,² so that the diagonal line in a diagram like Fig. 100 was replaced by a curved line convex upwards. No explanation was offered, but the same fact had been observed independently by Huntington and Desch (*loc. cit.*), who showed that the error was due to the segregation of copper from the eutectic, leaving a shell of copper phosphide surrounding the copper crystals. This shell appears as a band in the section (p. 204), and by measuring its area, calculating (from the known composition of the eutectic) the amount of copper which must have been removed by segregation in order to produce it, and deducting this from the observed area of copper, an accurate result is arrived at, as shown in the following table :—

¹ A. K. Huntington and C. H. Desch, *Trans. Faraday Soc.*, 1908, 4, 51.

² E. Heyn and O. Bauer, *Zeitsch. anorg. Chem.*, 1907, 52, 129.

Structure.	Area of crystals. Per cent.	Corrected area. Per cent.	Per cent. P by planimetric measurements.	Per cent. P by analysis.
Cu + eutectic	80.0	67.8	2.75	2.73
" "	42.0	36.4	5.30	5.08
" "	37.8	25.7	6.15	6.11
" "	37.0	36.0	5.38	5.45
" "	24.0	19.3	6.65	6.55
" "	11.2	6.8	7.60	7.88
All eutectic	—	—	8.27	8.25
" "	—	—	8.27	8.50
Cu ₃ P + eutectic	10.0	—	8.85	8.93
" "	10.0	—	8.85	9.05
" "	16.6	—	9.28	9.64
" "	21.8	—	9.50	9.59
" "	45.0	—	10.9	10.30
" "	50.0	—	11.2	10.70

The results obtained with alloys containing about 10 per cent. P are in some cases too high, apparently owing to undercooling.

Should the limiting concentrations found by microscopical examination differ from those found at higher temperatures by the thermal method, and the accuracy of the latter is not doubted, it is probable that the lines assumed to be vertical are really inclined. This is put to the test by quenching experiments, as described above.

It has been shown in Chapters XII. and XIII. that the more important physical properties of a series of alloys vary with the composition in a continuous manner so long as the solid phases remain the same, but that the appearance or disappearance of a phase at a certain limit of composition is frequently marked by a discontinuity. This fact may be utilized to determine the limits of composition at which each phase appears. The most important property from this point of view, in spite of the possibilities of experimental error that it involves, is the electromotive force. Next to it in importance, and supplementing its indications, stands the electrical conductivity, with which the hardness is closely associated. The specific volume and other physical properties enumerated can have only a subordinate importance from this point of

view. Only when the indications of one or more of these methods have been applied to assist in the interpretation of the microscopic structure can the constitution of the alloys be regarded as conclusively established.

The construction of diagrams representing the equilibrium of ternary systems differs only in complexity from that described, and does not involve any differences of principle; it is therefore unnecessary to give details, which must vary widely with the character of the system studied.

CHAPTER XV

THE MOLECULAR CONDITION OF METALS IN ALLOYS AND THE NATURE OF INTER-METALLIC COMPOUNDS

ALLOYS being regarded as solutions, the consideration of their molecular conditions forms a part of the general theoretical study of solutions. Whilst, however, the discussion of solutions in which the solvent is water or a similar liquid has been devoted mainly to dilute solutions, the solvent being in large excess, such a limitation is not possible in regard to alloys. The distinction between "solvent" and "solute" even becomes meaningless when dealing with mixtures of substances so closely allied to one another as are the metals, mixed in all possible proportions. The laws of dilute solutions are only applicable to a very small range of alloys at the two ends of each series. Further, no help is to be derived from theories of electrolytic dissociation, since electrolytic conduction does not occur in alloys, as has been proved by numerous experiments, and it is therefore impossible to infer the behaviour of the compounds which metals form with one another from an analogy with salts.

From the point of view of the molecular condition in solution, the alloys of mercury with other metals, the so-called amalgams, have naturally received most attention, owing to the fact that mercury and its dilute alloys are liquid at the ordinary temperature, so that freezing-point determinations may be carried out in an ordinary Beckmann's apparatus, and measurements of vapour pressure and surface tension may also be made—a proceeding which involves great experimental difficulties if applied to other metals. The amalgams have

also been much investigated from the point of view of their electrolytic potential, and of the velocity of diffusion within them.

THE FREEZING-POINT CURVE

In examining the molecular condition of dissolved metals we make use of the *atomic fall*, which is obtained by dividing the depression of freezing-point by the atomic percentage of the added metal. Such a procedure is only legitimate so long as the solution is dilute, that is, so long as the percentage of the second metal in the alloy is small, hence the advantage of closely grouped freezing-point determinations in the neighbourhood of the pure metals (p. 303).

The theoretical depression of freezing-point is given by van 't Hoff's equation—

$$\Delta = \frac{0.02T^2}{Q}$$

in which Δ is the depression due to 1 mol. of the solute in 100 mols. of solvent, T the absolute temperature of freezing, and Q the latent heat of fusion. This formula allows the molecular weight of the solute to be calculated from the observations if the latent heat is known, or conversely, the latent heat may be calculated if an assumption be first made as to the molecular condition of the solute. The formula has been applied in both ways. In the first place, the molecular weight of most metals dissolved in mercury has been found to be equal to their atomic weight,¹ the theoretical molecular fall being calculated as 2.12° , and the mean value obtained with several metals being 2.12° . Van 't Hoff's equation is, however, only applicable if the solid phase separating on freezing is the pure solvent, in other cases the atomic fall does not coincide with the molecular. Thus cadmium, even in the smallest quantities, *raises* the freezing-point of mercury. Tammann obtained similar results with sodium as solvent, and these mixtures were independently

¹ G. Tammann, *Zeitsch. physikal. Chem.*, 1889, 3, 441.

studied at the same time by Heycock and Neville,¹ who also found that the dissolved metals behaved, in the majority of cases, as if monatomic. In the case of gold in sodium, the curve extending from pure sodium to the eutectic alloy, containing 3.5 atomic per cent. of gold, is strictly rectilinear, and gives the atomic fall 4.5. Similar results were obtained by the same investigators, using as solvents tin,² bismuth, cadmium, lead,³ thallium,⁴ zinc,⁵ silver, and copper.⁶ The general conclusion arrived at is that the state of metals in dilute solution which do not form solid solutions is almost invariably that of single atoms. The latent heats of fusion and calculated molecular depressions of a few metals are collected in the following table⁷ :—

Metal.	T.	Q.	Δ
Hg	234°	566 cal.	1.94°
Na	370.5	730	3.75
Sn	505	1689	3.00
Bi	546	2635	2.02
Cd	595	1535	4.61
Pb	600	1111	6.47
Zn	692	1840	5.2
Ag	1234	2275	13.2
Cu	1357	2646	13.9
Fe	1778	1120	5.6
Pt	1983	5295	14.8

The formula given only applies to very dilute solutions, and cannot be employed to determine the form of the "ideal curve." A more complete formula, extending over the whole range of the freezing-point curve, was arrived at independently

¹ *Trans. Chem. Soc.*, 1889, 55, 666.

² *Ibid.*, 1890, 57, 376.

³ *Ibid.*, 1892, 61, 888.

⁴ *Ibid.*, 1894, 65, 31.

⁵ *Ibid.*, 1897, 71, 383.

⁶ *Phil. Trans.*, 1897, 189A, 25.

⁷ The figures given have been recalculated from the most recent available data.

by I. Schröder¹ and H. Le Chatelier,² on the assumption that the latent heat of fusion is unaltered by the addition of the second metal. The modified equation assumes the form—

$$\ln x = \frac{Q}{2} \left(\frac{1}{T_0} - \frac{1}{T} \right)$$

in which x is the molecular concentration of the solvent metal, that is, the fraction of a molecular weight of the solvent contained in every molecular weight of the mixture. Assuming the metals to be both monatomic in the alloy, $x =$ the atomic percentage of the solvent $\div 100$. The ideal freezing-point curve is then constructed by plotting the values of x from 1 to 0 against the values of T obtained from the equation. The curve thus constructed may have a point of inflection. The other branch is constructed by applying the same process to the freezing of the second metal. Heycock and Neville found that the ideal curve thus constructed for alloys of silver and copper agrees fairly closely, as regards the position of the eutectic point, at which the branches intersect, with that determined by experiment, although in this case solid solutions are formed to a limited extent.

It has been shown³ that by the introduction of corrections for the variation of latent heat with composition, and for the association of the solute in concentrated solutions, ideal curves corresponding very closely with those obtained experimentally may be drawn. The application of these corrections, however, demands a previous knowledge of the experimental freezing-point curve, so that the method cannot be used to predict the form of the latter, although it may prove of value in explaining abnormalities in certain instances.

¹ *Zeitsch. physikal. Chem.*, 1893, **11**, 449.

² *Compt. rend.*, 1894, **118**, 638. See also J. J. van Laar, *Proc. k. Akad. Wetensch. Amsterdam*, 1903, **5**, 424 ; **6**, 21.

³ D. Mazzotto, *Nuovo Cim.*, 1908, [v.] **15**, 401. The latent heat of fusion of a number of alloys has been determined experimentally by Mazzotto, *Mem. Inst. Lombardi*, 1891, **16**, 1 ; and by W. Spring, *Bull. Acad. Sci. roy. Belg.*, 1886, [iii.] **11**, 355.

VAPOUR PRESSURE

The influence of dissolved metals on the vapour pressure of mercury has been studied with the object of determining the molecular weight of metals in the alloyed condition,¹ again leading to the conclusion that the majority of metals are monatomic in liquid amalgams. Only dilute solutions can be employed, as at higher concentrations abnormal values are obtained, owing, in many cases, to the formation of compounds of mercury with the dissolved metal. The vapour-pressures are measured directly, and controlled by measurement of the vapour-pressure of pure mercury under precisely similar conditions. The metals Li, Mg, Zn, Cd, Ga, Sn, Pb, Bi, Ag, and Au are found by this method to be approximately monatomic.

ELECTROMOTIVE FORCE OF AMALGAMS

The number of atoms in the molecule of the dissolved metal may also be deduced from measurements of the E.M.F. of concentration cells, in which a salt-solution is used as the electrolyte, and the two electrodes are a concentrated and a dilute solution of the one metal in the other respectively. This method is only applicable, for experimental reasons, to liquid amalgams, and many experiments have been made in this direction. The E.M.F. of such a cell is given by the formula²—

$$E = \frac{RT}{n} \ln \frac{c_1}{c_2}$$

in which R is the gas constant, c_1 and c_2 the concentrations of the metal in the two amalgams, T the absolute temperature, and n the number of unit charges carried by one molecule of the metal. If the metal is monatomic, $n =$ the valency of the metal; if several atoms are associated to form a molecule, n is correspondingly greater, and dividing it by the valency, n' , gives the number of atoms in a molecule. The value n/n' is

¹ W. Ramsay, *Trans. Chem. Soc.*, 1889, 55, 521.

² G. Meyer, *Zeitsch. physikal. Chem.*, 1891, 7, 477.

found to be sensibly equal to 1 in amalgams of zinc, cadmium, lead, tin, copper, and sodium.¹

On the other hand, it has been shown by Haber² that the above conclusion is not strictly justified. The experimental results prove that the dissolved metals are present in solution either as single atoms or as compounds with mercury having the formulæ MHg_m . Haber obtains, as a more complete form of the above equation:—

$$E = RTm \frac{c_1}{c_2} + m \times 0.01474RT(c_1 - c_2)$$

Within the limits of error of the experiments, it is impracticable to distinguish between the two equations, and the results obtained therefore prove that atoms of zinc, etc., are not associated together in amalgams, but do not prove that they are not combined with mercury to form compounds of the general type MHg_m .

The objection raised by Haber to the conclusions from electro-chemical data is extended to the other methods of investigation by McPhail Smith,³ according to whom the freezing-point and vapour-pressure methods also only prove that either single atoms or molecules MHg_m are present. The question is really the same as that of the hydration of salts in aqueous solutions. Freezing-point and similar methods enable us to determine the molecular weight of the salt, but do not indicate clearly whether, and to what extent, the salt is hydrated. It is, in fact, far more difficult to determine how far the molecules of the solute are combined with those of the solvent than to determine the extent of association of the solute.

In simple eutectiferous series, in which the freezing-point curve shows no indication of the formation of compounds, we may safely accept the conclusion arrived at by the three

¹ A. Schöller, *Zeitsch. Elektrochem.*, 1898, **5**, 259; T. W. Richards and G. Lewis, *Zeitsch. physikal. Chem.*, 1899, **28**, 1; II. Fay and E. North, *Amer. Chem. J.*, 1901, **25**, 216.

² F. Haber, *Zeitsch. physikal. Chem.*, 1902, **41**, 399.

³ G. McPhail Smith, *Amer. Chem. J.*, 1906, **36**, 124; 1907, **38**, 671.

methods described above, that the dissolved metals are monatomic. In series in which compounds occur, it remains as yet an open question whether the same condition prevails, or whether compounds, containing a single atom of the dissolved metal in each molecule, are also present. The only experimental method which gives any indication of a definite answer to this question is that of measuring the velocity of diffusion in liquid metals. With the exception of some isolated experiments with molten lead, tin, and bismuth,¹ such measurements have been confined to mercury. Fick's law of diffusion, according to which the quantity diffusing through a given area in a given time is proportional to the rate of change of concentration, is confirmed in all cases.² The diffusion constant k , which is expressed in square centimetres per day, is given for a number of metals in the second column of the table, the solvent being mercury.³ Since the constants calculated in this way refer to weights of metal in grams, it is necessary to divide the value of k by the atomic weight of the metal diffusing.⁴ It is then found, on examining the atomic diffusivity as a function of the atomic weight, that whilst the metals Zn, Cd, Sn, and Pb, which do not form compounds with mercury, fall on a smooth curve (Fig. 101), the metals of the alkalis and alkaline earths, together with thallium, give points falling on an entirely distinct curve (the lower in the figure). These are metals known to form compounds with mercury, and the conclusion is drawn that the lower rates of diffusion observed for them are due to the fact that each atom of the diffusing metal carries with it a number, at present uncertain, of mercury atoms associated with it.

¹ W. C. Roberts-Austen, *Phil. Trans.*, 1897, 187A, 383.

² F. Guthrie, *Phil. Mag.*, 1883, [v.] 16, 321; W. Humphreys, *Trans. Chem. Soc.*, 1896, 69, 243, 1679. Both these experimenters placed the solid metal in contact with the mercury, rendering exact calculation impossible. See W. C. Roberts-Austen, *Proc. Chem. Soc.*, 1896, 12, 219. In later experiments, concentrated amalgams have been used instead of solid metals.

³ M. von Wogau, *Ann. Physik.*, 1907, [iv.] 23, 345.

⁴ G. McPhail Smith, *Zeitsch. anorg. Chem.*, 1908, 58, 381.

Metal.	$\frac{k = \text{cm.}^2}{\text{day}}$	$\frac{k}{\text{atomic weight}}$
Li	0.66	0.0939
Na	0.64	0.0278
K	0.53	0.0135
Rb	0.46	0.0054
Cs	0.45	0.0034
Ca	0.54	0.0135
Sr	0.47	0.0054
Ba	0.52	0.0038
Zn	2.18	0.0333
Cd	1.45	0.0129
Tl	0.87	0.0043
Sn	1.53	0.0128
Pb	1.50	0.0072

The form of the freezing-point curve in the neighbourhood of a maximum may also be studied as a means of gaining information respecting the behaviour of inter-metallic com-

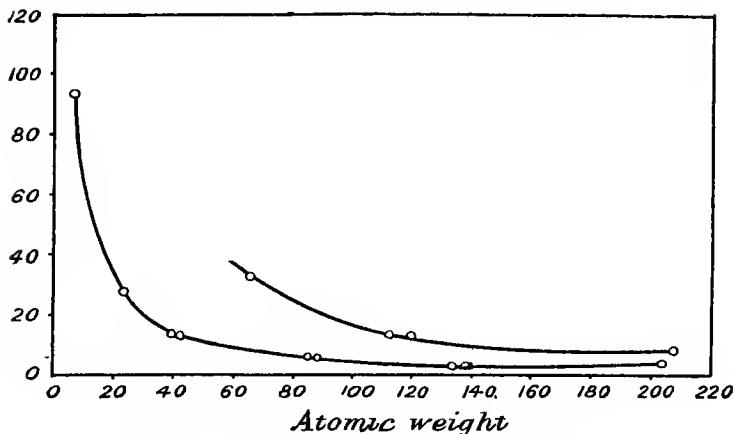

FIG. 101.—Atomic diffusivities of metals in mercury.

pounds in solution in liquid metals. The formation of an inter-metallic compound has in the simplest case the effect of breaking up the equilibrium diagram into two parts, each representing a simple binary system, the components being, in the one half, the metal A and the compound of A and B,

and in the other the same compound and the metal B. The entire diagram thus consists of two V-shaped curves. The intersection of the two intermediate lines at a point, however, would indicate that the compound melted without undergoing any dissociation into its components in the molten state. Although it is claimed that such a condition has been realized in the case of certain non-metallic mixtures,¹ there are thermodynamical grounds for supposing that such a condition is incompatible with equilibrium, and that the compound must undergo dissociation on melting, to however slight an extent.² Under conditions of equilibrium, the tangent to the curve at its highest point must be parallel to the axis of concentration. The greater the flattening of the curve near this point, the more completely we may suppose the compound to be dissociated into its components. The attempt has been made to calculate the extent of the dissociation by measuring the slope of the curve on each side of the maximum,³ and applying the principle of mass action. On each side of the maximum, the compound is in the presence of one of its products of dissociation, and approximate estimates have been made of the relative proportions of the undissociated compound and of the components at each temperature. The process involves many assumptions, rendering its application to alloys very hazardous. By adding an indifferent substance to the molten compound, however, and measuring the depression of freezing-point which it produces, a value may be obtained for the atomic lowering of freezing-point of the compound, and this may be applied to determine the extent of dissociation in the binary system.⁴ It is therefore possible that a systematic

¹ The freezing-point curve of mixtures of methyl iodide and pyridine has two lines intersecting at an apparently sharp angle. A. H. W. Aten, *Proc. k. Akad. Wetensch. Amsterdam*, 1904, 7, 468; *Zeitsch. physikal. Chem.*, 1905, 54, 127.

² H. A. Lorentz, *Zeitsch. physikal. Chem.*, 1891, 7, 36; R. Ruer, *ibid.*, 1907, 59, 1; 1908, 64, 357.

³ R. Kremann, *Monatsh.*, 1904, 25, 1215. Compare A. Findlay, *Trans. Faraday. Soc.*, 1907, 3, 153.

⁴ R. Kremann, *loc. cit.*, compare W. Stortenbecker, *Zeitsch. physikal. Chem.*, 1892, 10, 183.

investigation of ternary series may enable such calculations to be made. Given a binary system, containing a compound AB giving rise to a maximum in the freezing-point curve, and a third metal which forms simple eutectiferous series with each component of the binary series, observations of the slope of the curve of mixtures of AB with C should give the necessary data for estimating the dissociation of AB in the molten state.

The number of inter-metallic compounds already known is large, and new investigations constantly result in further additions to the list. When a report on the subject was drawn up in 1900,¹ the compounds tabulated numbered 37. A similar table drawn up in 1908,² to which only compounds were admitted the evidence in favour of whose existence was considered satisfactory, contained the formulæ of 109 compounds. This number is certain to be very greatly increased during the next few years.

It has been shown in the last chapter that the establishment of the existence and composition of an inter-metallic compound is a matter of considerable experimental difficulty, especially when, as is often the case, the compound is capable of forming solid solutions with one or both of its components.³ Two errors of method have been responsible for the introduction into chemical literature of a very large number of erroneous formulæ purporting to represent definite compounds. One of these is the attribution of a discontinuity of any physical property in a series of alloys at a certain composition to the existence of a compound having that composition. We have seen that such discontinuities occur at the point of appearance of a new phase, and that although their ultimate cause may be chemical combination, the formula of the compound cannot be directly inferred. The second error is that of assigning a definite formula to any crystals of homogeneous appearance, isolated from cooled alloys either mechanically or by treatment with chemical reagents. This

¹ F. H. Neville, "Report on the Compounds contained in Alloys," *Brit. Assoc. Rep.*, Bradford, 1900.

² C. H. Desch, *J. Inst. Metals*, 1909, i. 227.

³ See C. H. Desch, *Intermetallic Compounds* (London, 1913).

method has also been criticized in Chapter XIII. In spite of the progress which metallographic investigations have made, it is not uncommon to find mixtures of metals described as compounds on such insufficient grounds in chemical periodicals of the present day.

One important aid in fixing the formulæ of compounds which is available to the organic or inorganic chemist is denied to the metallographist. This is the application of the doctrine of valency. Whilst the formula of an organic compound which is inconsistent with the known valencies of the elements contained in it may be immediately ruled out—even the proposal to regard triphenylmethyl as containing tervalent carbon had only a short life—and the same principle is applied in the chemistry of inorganic compounds containing non-metals, the inter-metallic compounds are impossible to bring into the scheme of valency as generally understood. Such formulæ as NaHg_2 , AuSn_4 , Au_2Al , and Au_3Zn_5 do not accord with any usual valency that can be assigned to the atoms composing the molecules.

When one component of a compound has a semi-metallic character, the proportions in which it combines with a metal approach more nearly to those demanded by the respective valencies than when both components are markedly metallic. Thus antimonides and arsenides, even when possessing all the properties of true alloys, have formulæ in which the antimony may be represented without difficulty as tervalent, as in—

Ag_3Sb	Cu_3Sb	Mn_3Sb_2
AlSb	Fe_3Sb_2	Na_3Sb
Cd_3Sb_2	FeSb_2	Tl_3Sb
CoSb_2	Mg_3Sb_2	Zn_3Sb_2
CrSb_2		

The same valency may be retained for antimony in the following antimonides by assuming the metals Co, Cr, and Ni to be tervalent :—

CoSb	CrSb	NiSb
---------------	---------------	---------------

whilst the following formulæ, apparently well established, are less easily reconciled with the valency :—

AuSb ₂	Mn ₂ Sb	NaSb
CdSb	Ni ₄ Sb	ZnSb
Cu ₂ Sb	Ni ₅ Sb ₂	

The antimony appears to be quinquevalent in one of the compounds with nickel.

It is of course possible that the formulæ of some of the inter-metallic compounds may require to be multiplied by a factor, in which case it would become easier to assign valencies to their components, but the evidence necessary to determine the molecular weights of compounds in alloys is very scanty.

The more nearly the two components approach one another in chemical character, the less regular the formulæ of their compounds appear. Neither is it possible to predict with any certainty, from the compounds formed by a metal A with another B, the formulæ of the compounds which A will form with other metals belonging to the same group in the periodic classification as B. A few general rules have indeed been stated by Tammann,¹ but these are subject to many exceptions. Tammann's principal conclusions are—

1. Neighbouring elements in a natural small group do not form compounds with one another. Iron, however, appears to form a compound with nickel.

2. A given metal either combines with all the elements of such a group or with none. It does not follow, however, that these compounds will resemble one another in constitution. Thus cadmium combines with gold, silver, and copper, but the formulæ of the compounds exhibit no correspondence—

Cu ₂ Cd ₃	Ag ₂ Cd ₃	Au ₁ Cd ₃
Cu ₃ Cd	AgCd?	AuCd ₃
	AgCd ₃ ?	

Gold combines with lead to form Au₂Pb and AuPb₂, but neither copper nor silver combines with lead.

It has been suggested by Kurnakoff² that Mendeléeff's rule, according to which the total valency of an element is the sum of its valencies towards oxygen and hydrogen, and is

¹ *Zeitsch. anorg. Chem.*, 1906, 49, 113; 1907, 55, 289.

² *Ibid.*, 1900, 23, 439.

equal to 8, may be applicable to alloys, one of the metals taking the place of hydrogen. This would allow the alkali metals, which are univalent towards oxygen, to exhibit a valency as high as 7 in inter-metallic compounds. Whilst the number of atoms associated with one atom of the alkali metals in their compounds with other metals is often high, as in the following instances :—

KZn_{11}	NaCd_5	CsHg_4
NaZn_{11}	NaHg_4	CsHg_6
KCd_{11}	Na_2Pb_5	KBi_2

there is no evidence that such a rule applies.

If we assume that the metals only combine with one another by means of their latent valencies,¹ and regard the antimonides as resembling the sulphides and silicides rather than the true inter-metallic compounds, we no longer feel surprise at the irregularities in the apparent valencies exhibited by metals in alloys. The difficulty is, however, only thrown back a stage, and not removed, and the full explanation of these anomalies awaits the advent of a theory of valency sufficiently comprehensive to account for "latent" and "partial" valencies in a quantitative manner.

¹ See *The Theory of Valency*, by J. N. Friend, in this series, p. 155.

CHAPTER XVI

THE PLASTIC DEFORMATION OF METALS AND ALLOYS

METALS and alloys exhibit a certain degree of extensibility and compressibility. The application of a mechanical stress tending to cause extension, compression, or change of form results, in the first place, in the production of an elastic strain, that is, the solid undergoes a change of dimensions or of form during the application of the stress, returning to its original condition after the removal of the applied force. During this stage of perfect elasticity the strain produced is strictly proportional to the acting stress (Hooke's law); but when the stress exceeds a certain limit, this proportionality no longer prevails, and a solid subjected to tension, for example, elongates more rapidly than corresponds with its behaviour during the elastic stage. On removal of the tractive force, the solid does not return completely to its original condition, but retains a small permanent elongation. With further increases of stress, the permanent changes become more and more considerable relatively to the elastic changes. The compressibility of a metal is generally diminished by alloying.¹

Strains produced within the elastic range do not result in any visible change of structure. The alterations in certain properties of metals and alloys under elastic strain, such as the electrical conductivity and thermo-electric power, are of considerable interest, but the experimental difficulties have hitherto stood in the way of obtaining results which admit of expression in a general form.

The limiting stress of the elastic range, or "elastic limit," a magnitude of high technical importance in the investigation

¹ S. Lussana, *Nuovo Cim.*, 1910, [v.] 19, i. 182.

of structural materials, is variously taken as the point at which the strain ceases to be proportional to the stress, or as the point at which the permanent change exceeds a certain arbitrary small amount, depending on the sensitiveness of the testing apparatus employed. The two definitions are not quite equivalent.

The permanent alterations of volume or form resulting from the application of a stress in excess of the elastic limit are an object of study of the metallographist, as they are accompanied by visible changes in the macroscopic or microscopic structure, the character of which gives important information as to the internal arrangement of the component particles of the solid. Such changes are intimately connected with the crystalline structure of the metal or alloy, and may be employed as a means of distinguishing between closely related crystalline forms, as in certain cases to be discussed below. Their character varies with the nature as well as with the amount of the applied stress.

Pure compression, unaccompanied by any shearing stress, does not enter into consideration. The changes of density produced have been alluded to in Chapter XII., and are probably due in all cases to a lack of homogeneity in the specimens examined. A homogeneous solid is perfectly elastic under compression unaccompanied by change of shape. Deformation by stresses in excess of the elastic limit, however, may be accompanied by alterations in volume which persist after the removal of the stress, so that the deformed metal has a different density from the metal in a state of equilibrium. It has been shown in Chapter XII. that the density of the strained metal is generally less than that of the unstrained, bismuth being a conspicuous exception.

The metallographist is concerned with two distinct problems bearing on the non-elastic deformation of metals and alloys, namely, the mechanism of deformation, and the nature of the new physical condition indicated by the change in properties of a strained when compared with an unstrained metal.

Regarded in the mass, without reference to the microscopic structure, a metal exhibits a certain degree of plasticity, yielding

under tension, compression, torsion or bending, like pitch, and apparently only differing from the latter substance in the extent of its resistance to deformation. The resistance may vary from that of glass-hard steel or speculum metal, which breaks without appreciable deformation, to that of sodium or lead, which may be squeezed or moulded with ease. The plasticity of metals and alloys is generally under-estimated, and is only revealed to its full extent by experiments designed for the purpose. The fact that metals could be made to flow through openings by pressure, and to behave in other respects like fluids of high viscosity, was first demonstrated by Tresca,¹ who made evident the lines of flow in the mass by the device of employing thin superposed sheets of metal instead of solid blocks. Tresca's experiments have often been repeated under different conditions; and the results obtained by Spring, Tammann, and others show that the property of flowing through an opening, and even of forming a continuous wire, is not confined to metals commonly recognized as plastic, but is shared by such brittle metals as bismuth and antimony. The order of plasticity revealed by some of the most familiar metals is—

K, Na, Pb, Tl, Sn, Bi, Cd, Zn, Sb.

The fact that bismuth is more readily pressed into the form of wire than cadmium is remarkable, but in other respects the series is in accordance with the general behaviour of the metals.

This property of metals and alloys, of flowing like a viscous fluid when a sufficient pressure is applied, has been utilized in the technical production of tubes and rods. Lead and alloys of lead with tin or antimony are made into tubes by forcing the mass through a die having an annular opening, at a temperature sufficiently high to cause a marked increase of plasticity, but yet well below the melting-point. Alloys of copper and zinc are similarly "squirted" at a temperature below the melting-point, the process being only applicable to alloys containing the β constituent. The plastic yielding of metals

¹ *Compt. rend.*, 1864, 59, 754; 1865, 60, 398; 1867, 64, 809; 1868, 66, 263; 1869, 68, 1197; 1870, 70, 27, 288, 368.

during rolling, forging, wire-drawing, etc., is essentially of the same character.

The first metallographic problem named above is that of the internal mechanism of the plastic deformation. The superficial resemblance between the plastic behaviour of a crystalline solid and of an amorphous substance like pitch or glue is not due to an identity of the processes in the two cases. The flow of pitch is in every respect that of a liquid of high viscosity, but microscopical examination shows that the phenomena in crystals are of a quite different order. The problem was first studied in connection with the behaviour of large masses of ice. The indisputable fact that glaciers move like fluids of high viscosity was explained by Forbes¹ as being due to the plastic flow of ice-crystals under the action of slowly applied stresses. In opposition to this, it was maintained by Tyndall² that the flow was due to regelation, that is, that the pressure on the ice, by lowering the melting-point, caused the production of a small quantity of liquid water, allowing the grains of ice to roll or slide over one another, freezing and consequent re-consolidation of the mass taking place as soon as the stress was relieved. It will be seen that this explanation is necessarily confined to substances like ice, the melting-point of which is lowered by pressure. Other crystalline solids, however, behave like glacier ice. The well-known "creeping" of lead sheets on a sloping roof is of a similar nature, the weight of the lead causing it to flow downwards like a fluid of high viscosity. Ice is plastic at temperatures below those at which liquid water can be formed, and subsequent research has shown that plasticity is quite independent of regelation. As regards glaciers, the cause of flow was for long a subject of controversy, but the existence of true plasticity in the mass has now been placed beyond doubt.³

¹ J. D. Forbes, *Travels through the Alps of the Savoy*, 1845; *Proc. Roy. Soc. Edin.*, 1858, 4, 103; *Occasional Papers on the Theory of Glaciers*, 1859.

² J. Tyndall and T. H. Huxley, *Phil. Trans.*, 1857, 147, 327; J. Tyndall, *Glaciers of the Alps*, 1860.

³ See J. Ruskin, *Deucalion*, 1879, Vol. XXVI. of Collected Edition, 1906.

Many crystals are capable of being deformed without losing their crystalline character, from the oleates, which are so soft that two crystals brought into contact at a point unite to form a single one,¹ or potassium manganous chloride, a crystal of which may be pressed into a lenticular shape by the fingers without being cracked or broken,² to the apparently rigid crystals of calcite or rock-salt. Even these may be deformed to an extraordinary extent if certain precautions are taken. If enclosed in a metal tube, tightly packed with a powder, the tube may be bent or hammered so as to produce a great plastic deformation of the enclosed crystal without inducing fracture.³ Twinning planes are developed abundantly by such treatment, and the well-known planes of repeated twinning in the crystal grains of saccharoid marble are certainly due to flow under pressure, and may be reproduced artificially.⁴

Twinning planes are also of very frequent occurrence in metals and alloys which have been subjected to mechanical deformation. Microscopical examination has shown, however, that the mechanism of yielding under mechanical stress is for the most part of a finer character than twinning, and that displacement of the particles constituting a crystal takes place on a smaller scale, producing changes of structure which are less obvious but more important than the comparatively gross changes involved in twinning. If a piece of metal with a smooth, polished surface is bent or stretched, a number of fine lines make their appearance, running parallel to each other over the area of a single grain, but generally varying in direction from one grain to another. The crystalline structure of the metal is in this way made evident without etching, as the boundaries of the crystal grains are revealed by the abrupt changes in direction of the fine lines. The general effect is

¹ O. Lehmann, *Flüssige Krystalle*, Leipzig, 1904.

² O. Mügge, *Neues Jahrb. Min.*, 1889, i. 159.

³ G. A. Daubrée, *Geologie expérimentale*, Paris, 1879; Kick, *Zeitsch. Ver. deut. Ing.*, 1890, 11; 1892, 919.

⁴ F. D. Adams and J. H. Nicolson, *Phil. Trans.*, 1909, 195A, 363. Earlier experiments are due to J. Hall, *Trans. Roy. Soc. Edin.*, 1805, 6, 71.

seen in Plate XI., A, which represents a smooth surface of lead, cast in contact with glass, and lightly bent. The photo-micrograph shows the junction of three grains, and the lines, which are not perfectly straight, are seen to be parallel within each individual grain. It is not easy, at first sight, to recognize the true character of these lines; they are not cracks or ridges. Under oblique illumination, lines having any given direction are found to be visible only when the incident light falls on them from a particular direction, so that they alternately appear and disappear when the stage of the microscope is rotated. The lines are therefore shown to be steps, and the name of "slip-bands" has been given to them, as best expressing their character.¹ The height of each step is exceedingly small, but it has nevertheless been found possible to give a direct proof of its nature by means of a section perpendicular to the strained surface. Any attempt to render fine detail visible when occurring at the edge of a section fails owing to the unavoidable rounding of the edge during polishing. This difficulty has been overcome by the device of depositing a metal electrolytically on the surface to be studied, so that on cutting through the compound mass the original boundary appears in the middle of the section instead of at the edge, and is thus protected from the rounding action.² For example, in the examination of slip-bands in iron or steel, the surface on which the slip-bands have been developed by straining is first coated with a thin layer of copper by deposition from a cyanide solution (in order to avoid any attack on the iron), a thick layer of copper being then deposited from an acid solution. A section cut perpendicularly to the original surface shows the required detail at the boundary of the iron and copper. In this way Rosenhain has been able to show very clearly the stepped character of a surface crossed by slip-bands.

The formation of slip-bands takes place in the following way. The regular orientation of the particles in a crystal causes slipping of the particles over one another to occur

¹ J. A. Ewing and W. Rosenhain, *Phil. Trans.*, 1889, 193A, 353.

² W. Rosenhain, *Proc. Roy. Soc.*, 1905, 74, 557; *J. Iron Steel Inst.*, 1904, i. 335; 1906, ii. 189.

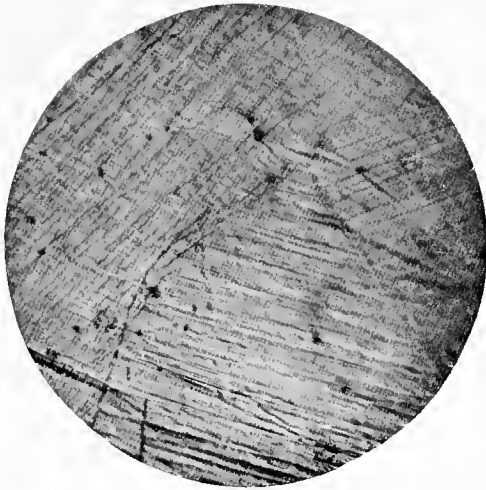

A. Strained surface of lead, showing slip-bands. $\times 86$.

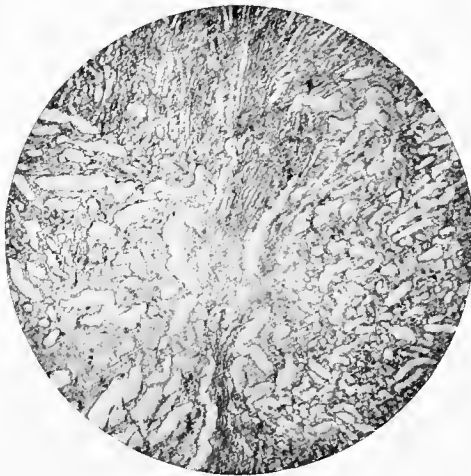

B. Pearlite in steel. $\times 300$.

PLATE XI.

[To face page 346.]

more readily in certain directions than in others, giving rise to systems of "gliding-planes." Fig. 102 represents diagrammatically the structure of a crystal, and it is evident that a motion of translation in the direction of the horizontal line may occur without any disturbance of the crystalline structure.

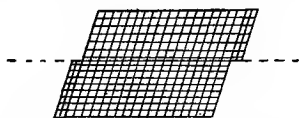

FIG. 102.—Translation along a gliding plane.

Translation may take place along that plane only, or along a number of planes parallel with one another. A crystal may possess several distinct systems of gliding-planes, the number depending on the class to which it belongs. Slip-bands are produced by successive small slips along gliding-planes of the same system. In Fig. 103, *a* represents a polished surface

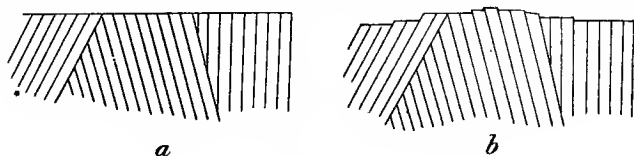

FIG. 103.—Formation of slip-bands.

before straining. Portions of three crystal grains are shown. The condition of the metal after straining is represented at *b*. Slipping has taken place along the gliding-planes, with the consequent production of inequalities of level. It is these steps on the surface which are known as slip-bands. The phenomenon exactly resembles the production of repeated faults, or "step-faults," in geological strata.

As every crystal possesses several systems of cleavage or gliding planes, slip-bands may be developed in several directions. The first effect of a moderate degree of straining on a crystal grain is usually to develop slip-bands in a single direction only. As the stress becomes more severe, or as its direction changes in the course of the redistribution of stress due to

local yielding, new systems of slip-bands appear, and several intersecting systems of lines are consequently observed on the surface of the specimen. Under high magnifications, the crossing of two slip-bands is seen to be marked by an abrupt dislocation, a fact which points clearly to their stepped character.

The plastic yielding of crystalline solids under stress is therefore due to slipping along innumerable gliding-planes without, in the first instance, any disturbance of the crystalline structure other than the translatory displacement of certain layers of particles relatively to others. It has been maintained by Heyn and others that a certain amount of plastic deformation takes place without the production of slip-bands, the metal yielding without alteration of structure; but Rosenhain has been able to prove by measurement that areas lying between slip-bands do not undergo change of form. A crystal grain may often be observed to remain free from bands when the section in which it occurs is deformed, but in such a case the dimensions of the crystal remain unchanged. The observations of O. Lehmann on protocatechuic acid indicate very distinctly that the plastic yielding, even of soft crystals, only takes place by slipping along a large number of gliding planes.

If the force applied to the solid is one of tension, producing elongation and lateral contraction, the component crystal grains are themselves elongated, becoming more or less spindle-shaped, so that a longitudinal section of the strained specimen has a very characteristic appearance under the microscope. A transverse section shows rounded polygonal grains, smaller in size than in the unstrained metal. When the elongation is very great, as in the drawing-down of wire through dies, the individual grains may be lengthened into fibres, and even divided, forming parallel bundles.¹ Severe mechanical straining, as in hammering or rolling, may result in the grains being actually driven into and through one another, so that the structure becomes minute and confused; it is therefore difficult to draw conclusions as to crystalline character and composition from the microscopical examination of such specimens, except after thermal treatment causing recrystallization.

¹ E. Heyn, *Zeitsch. Ver. deut. Ing.*, 1900.

As the formation of slip-bands in the manner described does not involve any change in the internal structure of the metal, all the motions being those of simple translation, etching removes all traces of the bands from the surface. Any bands remaining after etching must be of a different character. Persistent bands are indeed frequently observed in strained metals. In many cases these represent planes of repeated twinning, and such planes may occur so closely as to resemble groups of slip-bands. In addition to these, a piece of metal sufficiently large to be made up of many crystal grains may show after straining lines which are apparently independent of the crystalline structure. Such lines, which form systems of curves bearing a definite and calculable relation to the direction of the stress, occur both in crystalline and in amorphous substances, and have the same general form in both cases.¹ Nevertheless, their minute structure is probably different in the case of crystalline solids. Whilst the form of the curves represents the distribution of stress, they are probably made up, in the case of metals, of short cleavages approximately coinciding with the direction of the curve, the change from one cleavage to another being discontinuous, so that each curve, instead of being smooth, is stepped.

The different systems of lines developed by strain may be studied in isolated crystals. Whatever lines appear under such circumstances necessarily bear an intimate relation to the crystalline structure. The only metal which has been examined in any great detail from this point of view is iron, in which both the slip-bands and twinning planes may be well studied.² The behaviour of different faces of a crystal may be compared by studying the "percussion figures," or groups of curves and cleavage lines produced by striking the face to be examined with a pointed instrument. Such percussion figures

¹ F. Osmond, C. Frémont, and G. Cartaud, *Rev. de Métallurgie*, 1904, 1, 11; A. Mallock, *Proc. Roy. Soc.*, 1909, 82A, 26; see also C. Frémont, *Bull. Soc. d'Encouragement*, 1896, [v.] 1, 1218; F. Rogers, *Rev. de Métallurgie*, 1906, 3, 518; G. H. Gulliver, *Proc. Inst. Mech. Eng.*, 1905, 141.

² F. Osmond and C. Frémont, *Rev. de Métallurgie*, 1905, 2, 801; F. Osmond and G. Cartaud, *ibid.*, 1906, 3, 653; *J. Iron Steel Inst.*, 1906, iii. 144.

have been utilized in distinguishing between the different forms in which iron crystallizes.¹

FATIGUE

It is well known that materials subjected to frequent alternations of stress become "fatigued," the strength diminishing after the alternations have continued for some time. A metal subjected to rapid alternations of stress may break, even when the stress has never exceeded the known elastic limit of the material. A steel shaft in a factory, supported by brackets and carrying pulleys with belts, is subjected, not only to a more or less constant torsional stress, but to bending stresses which are varying in direction within the shaft at every moment during its revolution. It becomes important to discover the nature of the fatigue observed in such structures, and to determine the permissible limit of stress in each material. The stresses applied may also consist of alternate tension and compression, as in the connecting-rod of a locomotive, and many other varieties of stress are possible. Metals of high elastic limit are, in general, the best able to withstand repeated alternations of stress, a typical example being seen in the hard steel of which watch-springs are made.

Several different forms of machine have been employed in the experimental study of fatigue. In one of the most convenient, due originally to Wöhler, a cylindrical rod of the material is made to project from the end of a revolving shaft, the overhanging end being loaded by means of a ring slipped over it, bearing a weight or forming the upper attachment of a spring balance. The stress is in this case a bending one, varying rapidly and continuously within the metal, as in the factory shaft referred to above. By polishing a portion of the surface of the test-piece, and examining from time to time under the microscope, the mechanism of fatigue has been very completely studied.²

¹ F. Osmond and G. Cartaud, *Rev. de Métallurgie*, 1905, 2, 811, and *loc. cit.*

² J. A. Ewing and J. C. W. Humfrey, *Phil. Trans.*, 1902, 200A, 241.

Even although the stress, calculated on the specimen as a whole, may be well below the elastic limit, it may not be uniformly distributed throughout the mass, so that certain crystal grains are more severely stressed than others. Slip-bands make their appearance in these grains after a certain number of reversals, and their number increases as the test is continued. The slipping which takes place leads to a redistribution of stress among the crystal grains, and after a time a larger number of grains are found to exhibit slip-bands. Some of the slip-bands develop into cracks, and a crack once started propagates itself rapidly, through causing a local intensification of the stress. From this point onwards, the behaviour of the specimen is similar to that of a bar containing an internal flaw, the remainder of the metal is little affected by further alternations of stress, but that in the immediate neighbourhood of the crack or flaw is very greatly affected. An important result obtained by Ewing and his co-workers, is that fracture does not take place along the boundaries of the crystal grains, but preferably through the grains, along the path of the slip-bands.¹

It has been seen that the production of a slip-band is due to the gliding of crystal elements over one another along a plane of translation, and that this action does not bring about a change of crystal structure. As the stress is reversed, motion along the same plane, but in the opposite sense, may take place. If this were the only action, it would be possible for reversible deformations to occur at each alternation, the displaced layers gliding to and fro over one another without destroying the crystalline structure of the metal. The fact that fatigue occurs is itself a proof that the actual sequence of events is not so simple. Further, one of the best-known phenomena in the mechanical behaviour of metals is the increase of hardness which results from the application of severe strains. A piece of soft copper drawn into wire through a die, a silver button

¹ This statement is only made with reference to homogeneous materials. In a substance containing layers of brittle intercrystalline material, such as copper containing bismuth, the fracture naturally follows the crystal boundaries.

rolled out into a narrow strip, and a sheet of cartridge brass forced into a cup shape by a hydraulic press, are familiar examples of the hardening effect of severe mechanical work on crystalline substances. Soft metals become hard and elastic, and even brittle, under such treatment. It therefore appears that the metal undergoes a molecular change when the amount of deformation along gliding planes becomes excessive, or when alternations of stress have led to repeated rubbing of the gliding surfaces over one another.

Ewing and Humfrey observed that the slip-bands on the polished surface of a sample of mild steel, after 40,000 reversals of stress, showed a marked change in appearance. By careful focussing it was found that a distinct ridge was produced along the elevated edge of the slip-band, having the effect of a burr produced by the friction. It is also known that a strained plastic metal, such as iron, recovers its original properties to some extent after being kept for some time, or very rapidly if heated to a moderate temperature, such as 100°. ¹ This indicates that the strained, hardened metal is in an unstable condition, and that its constituent molecules are under some degree of restraint, from which they are prevented from escaping by the high viscosity of the solid. Return to the stable condition takes place spontaneously, although very slowly, and is enormously facilitated by the reduction of internal viscosity due to rise of temperature.

Experiments of this kind do not determine whether the molecular change extends through the whole mass of metal, or is confined to the immediate neighbourhood of the rubbing surfaces. The latter is the more probable in view of the fact that the hardening process is progressive, the hardness increasing with the amount of work done on the solid. An explanation covering all the facts is due to Beilby, based on observations of the changes in the surface of crystals during polishing. The results to be described in the next section explain very satisfactorily the phenomena of hardening and fatigue.

It remains to be said that fractures resulting from the

¹ J. Muir, *Phil. Trans.*, 1899, 193A, 1 ; 1902, 198A, 1.

opening-up of slip-bands, consisting as they do of systems of cleavage planes, commonly present a bright, crystalline appearance, which has led to the popular belief that metals subjected to alternating stress become "crystalline." This is not so; a microscopical examination of the metal immediately behind the fracture shows that the structure has not become coarser, that there is no real increase in the size of the crystal grains, but that the brilliant facets on the fractured surface are merely cleavage planes. The same metal will exhibit entirely different fractures if broken under tension and under alternating stress, the whole of the crystals being gradually deformed in the former case, giving a fine fracture, whilst in the latter the yielding is confined to a few cleavage planes. Fracture by shock, causing separation to take place along the planes of greatest weakness, without giving time for a readjustment of stresses by the plastic yielding of other crystals, also produces a coarsely faceted or "crystalline" surface.

Alternating stresses may be applied in several different ways, in addition to that already described. In Sankey's apparatus a flat bar, clamped at one end, is bent backwards and forwards through a fixed angle; in another form a bar, held at both ends between rollers, is alternately thrust and pulled at the middle point by a grip moved by an eccentric. Reversals of direct stress have also been employed, the specimen being placed alternately in tension and in compression.¹ Although the methods of applying the stress vary, the process of yielding is, in all cases, essentially that described above.

THE NATURE OF POLISH

It has been stated in Chapter VII. that there is a fundamental difference between the process of abrasion by a material such as emery and that of polishing. The action of an abrasive material is one of cutting. Each particle cuts a fine groove in the surface over which it rubs, the groove being ploughed in a soft substance, or broken out in a series of chips in a brittle substance. The form of the groove, which is

¹ T. E. Stanton, *Proc. Inst. Mech. Eng.*, 1905, 897.

made up of minute paraboloids, is approximately a parabolic cylinder.¹ The use of a somewhat finer abrasive material effaces the coarser scratches by substituting for them a system of finer grooves. This process may be carried very far, but even the finest abrasive material only cuts grooves, although these may be of microscopic fineness. Robert Hooke, who examined the surface of a steel razor under his microscope, and described the minute scratches which he observed, wrote, in 1665²—

“And indeed it seems impossible by Art to cut the surface of any hard or brittle body smooth, since *Putte*, or even the most curious *Powder* that can be made use of, to polish such a body, must consist of little hard rough particles, and each of them must cut its way, and consequently leave some kind of gutter or furrow behind it.”

More recent research has shown, however, that the process of polishing is of quite a different order. Polishing powders consist of fine particles which may be, on account of their softness, quite incapable of cutting grooves in the solid which is being polished. Rayleigh³ suspected that the polishing process was really molecular in character. The union between the powder and the polished surface is very intimate. If a polishing cloth covered with rouge is allowed to become dry, the rouge may attach itself so firmly to the metal surface that it cannot be removed without destroying the smoothness of the latter, and similar phenomena, indicating some degree of interpenetration between the two substances, are well known.

Beilby has shown⁴ that the effect of polishing is to cause a surface flow of the substance being polished. When an alloy containing lead together with a harder metal is rubbed vigorously on the polishing block, the lead is caused to flow, and may cover the whole surface, completely masking the underlying structure. This effect is well known to beginners who

¹ F. Osmond and G. Cartaud, *Rev. gén. Sciences*, 1905, 16, 51.

² *Micrographia*, Observation II. This was also the opinion of Herschel.

³ *Proc. Roy. Inst.*, 1901, 16, 563.

⁴ G. T. Beilby, *Proc. Roy. Soc.*, 1903, 72, 218, 226; *Phil. Mag.*, 1904, [vi.] 8, 258; *J. Soc. Chem. Ind.*, 1903, 22, 1166.



A. Surface of bismuth, marked with emery scratches. $\times 200$.

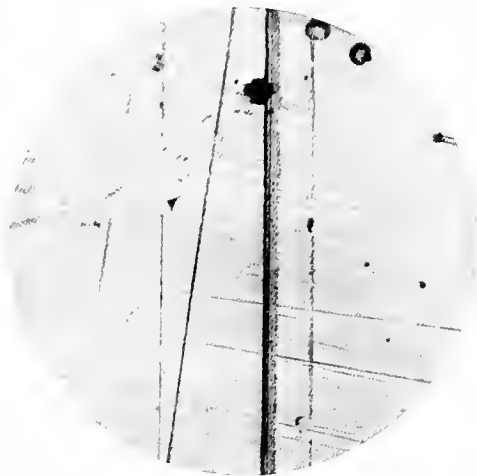

B. Surface of bismuth, partly polished. $\times 200$.

PLATE XII.

[To face page 355.]

attempt to polish soft alloys. Flow takes place, although only to a small depth, on the surface of even the hardest crystalline substances, and Beilby has demonstrated the existence, on polished surfaces, of a thin layer of flowed, structureless material, strongly resembling in its behaviour a highly viscous fluid. The "forced polish" produced by burnishing is due to the formation of a deep layer of this flowed material. Its formation is well shown on the surface of such a brittle metal as antimony. A surface crossed by emery scratches is lightly polished on a wet cloth block with alumina, and by examining from time to time under the microscope, the gradual conversion of a part of the metal into the viscous form may be watched. If the direction of the polishing is kept constant and transverse to the scratches, the flowed material is seen to form an overhanging ledge or cornice at the edge of the grooves, then extending to form a complete bridge. By forced polishing it is easy to cover up even deep scratches in this way with a flowed layer, presenting the appearance of a perfectly smooth, polished surface. That the scratches are only covered, and not removed, is readily seen on etching with a reagent, which dissolves the film, and exposes the original grooved surface. Beilby has shown by photographing at various stages that grooves and pits on metals, and also on calcite, may be filled up or bridged over in this way, and again exposed by the application of an etching reagent. In the same way, an etched pattern may be completely effaced by polishing, and a light re-etching removes the film and again exposes the underlying pattern. Plate XII., A, is a photo-micrograph of a surface of bismuth crossed by numerous scratches produced by emery paper. Plate XII., B, is a photo-micrograph of the same specimen polished with alumina on a cloth. Most of the scratches are completely covered by a film, some fine ones appear broken, having been bridged in places, whilst one broad scratch is in process of being filled. It is from this cause that etching a polished micro-section so often reveals scratches which had apparently been removed during its preparation and finishing.

The surface layer is harder than the mass of the solid and

observations on calcite have shown¹ that it is the same in all directions, whilst the hardness of a crystalline substance is different in different directions. The orientating influence of a crystal can, however, make itself felt under certain circumstances even through such a layer, as parallel growths of potassium nitrate on calcite are found to occur even when the surface of calcite used is not a fresh cleavage face, but one prepared by polishing, and therefore covered with a viscous film. The thickness of the film, in the case of calcite, is of the order of 10^{-4} mm.

The application of these facts to the hardening of metals by work may now be seen. Wherever two crystalline surfaces rub

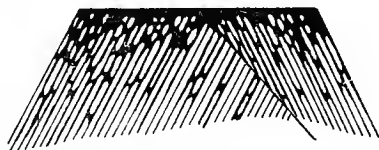

FIG. 104.—Formation of amorphous material in polished and strained metal.

together, a viscous flowed layer is produced. The quantity of the amorphous material produced in the gliding of one layer of crystal elements over another may be insignificant, but each repetition of the slipping causes it to increase. A piece of metal subjected to alternating stresses exhibits slip-bands, which are evidence that motion along gliding planes has taken place in some of the crystal grains. In the course of the to-and-fro motion of the crystalline layers, the rubbing surfaces are converted more or less completely into the amorphous material. As slipping does not take place readily along the hardened surfaces, new gliding planes are opened up, and the process continues until the supply of crystalline material is considerably reduced, or until it is broken up into small masses surrounded by and enclosed in amorphous hardened metal. This condition is shown diagrammatically in Fig. 104, the hardened material being represented in black. When this

¹ G. T. Beilby, *Proc. Roy. Soc.*, 1909, **82A**, 599.

state of things is reached, alternating stresses very readily lead to the formation of a crack, which therefore has its origin in the breaking-down of the crystalline structure.

It is not possible, even by the most severe treatment, such as drawing a ductile metal repeatedly through smaller and smaller dies, to convert the whole of a mass of metal into the amorphous modification. The distorted crystal grains, even when drawn out into fine threads, retain a crystalline core, merely enclosed in an amorphous shell.¹ This sets a limit to the amount of hardening which can be impressed on a metal by work at the ordinary temperature. The hard envelope probably prevents the enclosed crystalline portions from yielding, so that fracture takes place when a further stress is applied.

This theory explains the known facts of hardening and polishing with remarkable completeness. The amorphous modification has much analogy with a vitreous substance, such as a glass or undercooled liquid. It must be regarded as unstable at all temperatures, and only prevented from returning to the stable, crystalline condition by its internal viscosity. Hence the tendency, already mentioned, to spontaneous recovery from overstrain, especially when the temperature is raised. The complete crystallization at higher temperatures will be considered immediately.

The suggestion has been advanced recently² that the process of flow is one of actual melting. Although an increase of pressure generally raises the melting-point of a metal, pressure acting locally in such a way that the liquid formed is free to escape has the effect of lowering the melting-point.³ Calculation shows that lead would melt at 27° under a pressure of 1760 atmospheres, and copper at the same temperature under 24,000 atmospheres. The order of the pressures required to melt the metals, as calculated from their latent heat of fusion and their density, corresponds perfectly with the observed order of plasticity. It is, however, difficult to imagine that

¹ G. T. Beilby, *Proc. Roy. Soc.*, 1905, 76A, 462; 1907, 79A, 463.

² J. Johnston, *J. Amer. Chem. Soc.*, 1912, 34, 788.

³ J. H. Poynting, *Phil. Mag.*, 1881, [v.] 12, 32.

such enormous pressures can be attained locally, and yet be confined to the crystals.

On the other hand, it has been maintained that the hardening process is one of the repeated subdivision of the crystals along cleavage planes, and that an amorphous material is not produced at any stage.¹ This view has been developed in great detail, but appears to take insufficient account of the evidence from microscopic structure, and from the observation of polished surfaces. A molecular theory of the alteration produced in crystalline substances by fatigue, depending on the assumption that the molecules or crystal-elements possess polarity of some kind, has been elaborated by Ewing.²

THIN FILMS

The formation of the amorphous modification, and its recrystallization under the influence of a rise of temperature, are very conveniently studied in thin metallic films, such as gold-leaf, which are prepared by beating. It was observed by Faraday as far back as 1857³ that a gold leaf supported on glass becomes transparent, and loses its reflecting power, when heated to a very moderate temperature. Thin beaten gold leaf is truly transparent, transmitting green light. Treatment of such a film with a dilute solution of potassium cyanide causes the removal of the amorphous modification, leaving the crystalline residue in a spongy form. The effect of heating the foil supported on glass is to give sufficient mobility to the film to allow it to behave as if fluid, so that its particles gather themselves into aggregates apparently under the influence of surface tension. Hence the increased transparency, and the transmission of white instead of green light, is due to this aggregation into globules, between, and not through, which the

¹ O. Faust and G. Tammann, *Zeitsch. physikal. Chem.*, 1911, 75, 118; G. Tammann, *Zeitsch. Elektrochem.*, 1912, 18, 584.

² *Brit. Assoc. Rep.*, York, 1906, Presidential Address to the Engineering Section.

³ *Phil. Trans.*, 1857, 147, 145; *Exp. Researches in Chemistry and Physics*, 1859, 391.

light passes. This is confirmed both by direct microscopical observation and by measurements of the electrical resistance, which increases from a small value (0.2 to 50 ohms) for the original foil, up to thousands of megohms for a specimen rendered transparent by heating at 300°.¹ At so high a temperature as this, the gold is rendered crystalline, but the discontinuity produced by aggregation while still partly amorphous is the cause of the increased resistance. The green colour and brilliant metallic lustre must be attributed to the flowed layer. They can be restored to the gold leaf crystallized by heat by burnishing, a process which re-forms the flowed layer. Silver resembles gold in these respects, a fact also observed by Faraday.

The properties which distinguish metals and alloys hardened by mechanical work from the same substances in a state of equilibrium are due, on this view, to the presence of an amorphous modification in the former. The electrical resistance is raised by straining, and the original value is regained after annealing at a temperature sufficiently high to cause recrystallization. The elasticity which enables a soft copper or silver wire, after drawing, to act as a spring, is an even more characteristic property of strained metals than their hardness. The electric potential is changed, a part of the energy which has been absorbed during the working reappearing when the metal is placed in contact with an electrolyte in which it can dissolve. Hence a worked metal, connected with a piece of the same metal in an annealed or fully crystalline condition, to form a voltaic cell, becomes the anode,² and develops an increased quantity of heat in the process of solution.³ This existence of a difference of electrolytic potential between strained and unstrained metals is of considerable importance in dealing with the probability of corrosion in structures in which worked and unworked metals are in contact.

¹ Beilby, *loc. cit.* The changes in gold and silver films have also been studied by T. Turner, *Proc. Roy. Soc.*, 1908, 81A, 301.

² C. E. Fawsitt, *Proc. Roy. Soc. Edin.*, 1906, 25, 2; *J. Soc. Chem. Ind.*, 1906, 25, 1133.

³ M. Berthelot, *Compt. rend.*, 1901, 132, 234; C. Barus, *Bull. U.S. Geol. Survey*, Bull. 94.

A property which may be very conveniently employed in the study of the hardened modification is the thermo-electric force developed when the hardened and annealed specimens are placed in contact.¹ Using silver wires, Beilby has observed an E.M.F. as high as 0.17 microvolt per 1° of difference between the temperatures of the hot and cold junctions. By raising the temperature and measuring the E.M.F. from time to time, the point at which annealing sets in may be observed. When the annealing process is complete the two wires become identical, and the thermo-electric force falls to zero. With most metals, the annealing change sets in somewhat suddenly, so that the E.M.F. curve exhibits an abrupt discontinuity; but this point cannot be regarded as a true transition temperature, as one of the modifications has no range of stability, but is unstable at all temperatures. The break in the curve represents the temperature at which the molecular mobility becomes sufficient to permit crystallization to take place.

The recrystallization of gold begins at 250°, that of copper at 200°.² The temperature is higher for alloys, being near 300° for brasses containing 10 per cent. or 33 per cent. Zn.³ After heating at temperatures above these, the process of recrystallization may be watched microscopically.

The behaviour of some metals and alloys when subjected to stress at high temperatures has, however, led to the suggestion⁴ that the amorphous phase disappears only at a higher temperature, which has been determined to be 650° for copper, 395° for aluminium, and 710° for an alloy of 80 per cent. of copper and 20 per cent. of nickel. It is not easy to reconcile such a supposition as that just described with other facts, and the experimental results are perhaps susceptible of a different interpretation.

¹ M. Maclean, *Proc. Roy. Soc.*, 1899, **64**, 322; 1900, **66**, 165.

² Beilby, *loc. cit.*

³ A. Portevin, *Rev. de Métallurgie*, 1909, **6**, 814; see also A. Le Chatelier, *Génie civil*, 1891, **19**, 59.

⁴ G. D. Bengough, *J. Inst. Metals*, 1912, **7**, 123.

CHAPTER XVII

THE METALLOGRAPHY OF IRON AND STEEL

THE technical importance of the metallography of iron and steel, and the extraordinary complexity of the relations exhibited by these metals, justify the separate treatment of this group, the literature of which exceeds in volume that of all the other departments of metallography taken together. The equilibrium of iron and carbon will therefore be considered in some detail, a briefer account being subsequently given of the modifications brought about by the introduction of other elements into the system. An outline of the constitution of metallic meteorites will conclude the chapter.

Molten iron dissolves carbon very readily up to a certain limit. A saturated solution at 1400° contains about 6 per cent. C, and although much more may be dissolved by raising the temperature, the excess is deposited on cooling in the form of graphite, which separates very readily on account of its lightness, so that it is difficult to obtain solid alloys containing more than 6 per cent. C, and even this value can only be obtained under certain conditions. The very light, crystalline graphite which collects on the surface of iron rich in carbon is well known in iron works under the name of "kish" (Germ. *Garschaum*).

That the melting-point of iron is depressed by the addition of carbon, is one of the most familiar facts of the iron industry. An alloy containing 4 per cent. C melts near 1100° , or 400° below the melting-point of pure iron. The first freezing-point diagram was constructed by Roberts-Austen in 1899,¹ and the

¹ 5th Report, Alloys Research Committee, *Proc. Inst. Mech. Eng.*, 1899, 35.

data which it contained were utilized in the following year by Roozeboom¹ in the construction of a complete diagram of the phase equilibrium. To give an account of the modifications which this diagram has undergone at the hands of later investigators, and of the controversies to which the proposed modifications have given rise, would occupy more space than can be given here, and reference must merely be made to some of the most recent reviews of the subject.² The diagram represented in Fig. 105 embodies the conclusions which are most widely accepted at the present time, certain of them being avowedly provisional. A somewhat revolutionary diagram, recently proposed, will be indicated later.

The chemical study of iron and steel, which preceded the metallographic study, had established the fact that carbon may exist in steel or in cast-iron in three different forms, namely graphite, "carbide carbon," and "hardening carbon." Of these, the first is identical with natural graphite, the second corresponds with a carbide which is known to have the composition Fe_3C , whilst the third form of carbon is present in a state of solid solution. The diagram has to account for these different conditions.

Beginning at the left-hand side of Fig. 105, the freezing-point of iron is taken as 1505° .³ Iron is now generally considered, in accordance with Osmond's hypothesis, to exist in three allotropic modifications. Although all three forms crystallize in the regular system, and crystallographic differences between them are doubtful, yet the undoubted discontinuity of properties at certain well-defined temperatures, marked by energy and volume changes, prove the fact of physical transformations which are conveniently termed allotropic. Direct evidence of the allotropy has been obtained

¹ *Zeitsch. physikal. Chem.*, 1900, **34**, 437; *J. Iron Steel Inst.*, 1900, ii. 311.

² P. Goerens, *Erstarrungs- und Erkältungsvorgänge bei Eisenkohlenstofflegierungen*, Halle, 1907; H. M. Howe, *Metallurgie*, 1909, **6**, 65, 105; F. Wüst, *ibid.*, 512.

³ H. C. H. Carpenter, *J. Iron Steel Inst.*, 1908, iii. 290; in good agreement with B. Saklatwalla, *ibid.*, ii. 92, and H. Harkort, *Metallurgie*, 1907, **4**, 646.

by straining a strip of iron, heated by the passage of a current *in vacuo*. Within the ranges of temperature corresponding respectively with the stability of the three modifications, different systems of slip-bands are obtained, indicating distinctly different mechanical properties.¹ The γ -iron, which forms at the freezing-

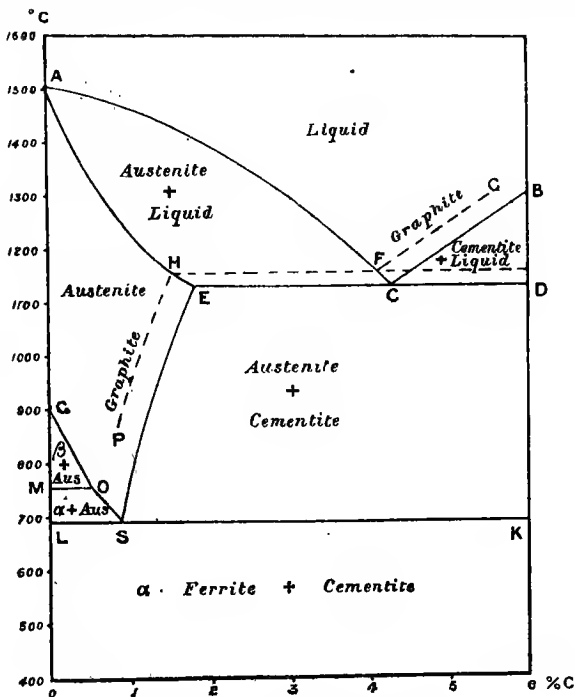

FIG. 105.—Alloys of iron and carbon.

point, has a considerable solvent power for carbon, and is the only modification capable of forming concentrated solid solutions. At about 900° it passes into the β form, the change being accompanied by a development of heat, and by a considerable expansion of volume. This critical point is denoted by Ar_3 (A standing for *arrêt*, r for *refroidissement*. The

¹ W. Rosenhain and J. C. W. Humfrey, *Proc. Roy. Soc.*, 1910, 83A, 200.

corresponding change on heating is denoted by Ac_3 , c standing for *chauffage*; the two points coincide under conditions of equilibrium). At 760° , β -iron changes into the α modification, with development of heat, but with very little alteration in volume. This point is termed Ar_2 , and is less sharply marked than Ar_3 .

It is not certain whether β -iron has the property of retaining carbon in solid solution.

γ -Iron is not itself hard, but is capable of forming solid solutions with carbon in the form of carbide, which become hard under certain conditions of cooling. In the absence of carbon, the transformation into β - and α -iron takes place with such facility that even rapid quenching is insufficient to retain it in the γ form.

Returning to the upper part of the diagram, the freezing-point of iron is depressed by carbon, the curve having the form indicated. A eutectic point is reached at 4.3 per cent. C and 1125° . The solid phase which separates along this descending branch of the curve is not pure iron, but a solid solution of carbon in γ -iron, which, when saturated at 1125° , contains about 1.8 per cent. C, indicated by the point E.

The determination of the exact form of the solidus AE is difficult by purely thermal means, as the end of solidification is not very distinctly marked on the cooling curves, but it has been accomplished by the application of Heycock and Neville's method of quenching. Several specimens of the same composition are quenched from temperatures near to the supposed position of the solidus. Microscopical examination then shows which of these specimens contained liquid material at the moment of quenching. Another, quenched from a slightly lower temperature, is found to have been completely solid, and by a repetition of such experiments the point at which the cooling curve of each alloy intersected the solidus is determined.¹

To the solid solution separating along the branch AB is given the name of austenite. Its physical properties, when

¹ N. Gutowsky, *Metallurgie*, 1909, 6, 731, 737.

preserved by rapid quenching, will be described later. Its limit of saturation is reached at 1.8 per cent. C. Solutions containing a larger quantity of carbon deposit austenite until this concentration is reached, and the remainder of the liquid solidifies as saturated austenite together with a eutectic. The nature of the eutectic depends on the conditions of experiment. We will first assume that precautions are taken to exclude silicon, and that the rate of cooling during solidification is not unduly slow. In this case, the solid phase in equilibrium with austenite at 1125° is cementite Fe_3C , which does not form solid solutions. Free cementite crystallizes from liquid alloys containing more than 4.3 per cent. C, as indicated by the curve BC. At the eutectic point C, the two phases, cementite and saturated austenite, crystallize simultaneously. This eutectic structure is observed in white cast-iron.

On cooling saturated austenite below 1125° , its concentration is reduced by the separation of crystals of cementite, the solubility curve having approximately the form ES.¹ At 690° the limit of saturation of the solid solution is only 0.9 per cent. C.

The transformation of γ - into β -iron also occurs where the γ -iron is present in the form of a solid solution. In accordance with the general behaviour of solid solutions, the temperature of the transformation is lowered by the presence of carbon. Consequently, in a steel containing a small quantity of carbon, the transformation Ar_3 does not take place at 900° , but at a lower temperature. The curve GO represents this change. It is uncertain whether β -iron retains carbon in solid solution or not. We may assume provisionally that it does not, and that austenite consequently deposits pure, carbon-free iron when the curve GO is crossed. The temperature of the second transformation Ar_2 , by which β -iron changes into α , is then unaffected by the presence of carbon, as it is confined to the separated pure metal. The line MO is therefore drawn as a horizontal line. Should β -iron prove to have a small solvent power for carbon, this line must be more or less

¹ The form of the curve ES has been taken from the results of N. J. Wark, *Metallurgie*, 1911, 8, 704.

broken, but the difference is not material. From the point O onwards, the transformation Ar_2 vanishes, or coincides with Ar_3 , as α -iron separates directly from the solid solution of carbide in γ -iron along the curve OS, without an intermediate passage through the β stage. The transformation along OS is often denoted by Ar_{3-2} . On reaching the composition 0.9 per cent. C, this line intersects the curve of separation of carbide, and the point of intersection is a *eutectoid* point (p. 59). It represents the breaking-up of the residual solid solution, containing 0.9 per cent. C, into a complex of ferrite (iron containing very little, if any, carbon), and the carbide, cementite. This intimate eutectoid mixture is known as pearlite.¹

The behaviour of several alloys, containing different percentages of carbon, may now be examined, when they are cooled from a temperature immediately below the solidus. A steel containing 0.3 per cent. C will have the following arrest points—

$$Ar_3 \ 820^\circ, \ Ar_2 \ 760^\circ, \ Ar_1 \ 690^\circ.$$

With an increase of the carbon to 0.7 per cent., the points Ar_3 and Ar_2 coincide, and we have two arrests only—

$$Ar_{3-2} \ 730^\circ, \ Ar_1 \ 690^\circ.$$

The eutectoid alloy, with 0.9 per cent. C, has only a single arrest-point, Ar_1 , at which the change of γ - into α -iron, and the resolution of the solid solution into ferrite and cementite, take place simultaneously. As Ar_1 is the recalescence point, already referred to (p. 209) the magnitude of the recalescence effect is a maximum for steel of this composition. Passing to the alloy containing 1.5 per cent. of carbon, we again meet with two arrest points, the first, Ar_{3-2} , corresponding with the separation of cementite from the solid solution, and the second, Ar_1 , with the resolution of the eutectoid mixture. Whatever be the

¹ The form of the curve GOS has been determined by means of systematic quenching experiments by P. Goerens and H. Meyer, *Metallurgie*, 1910, 7, 307.

composition of the initial solid solution, it deposits a part of its iron whenever the point representing its composition intersects the curve GOS, or a part of its cementite if it intersects the curve SE. The solid solution remaining when the temperature has fallen to 690° has in every case the composition represented by the point S, and is transformed into pearlite.

The diagram just described does not represent the whole of the facts, although it affords a clue to the behaviour of the alloys comprised within its range. The solid solution, referred to provisionally as austenite, undergoes partial resolution so rapidly when passing through the critical range of temperature, that even the most rapid quenching fails to retain the solid solution formed on freezing, in a metastable state. In ordinary quenching experiments, therefore, one obtains mixtures of austenite with ferrite and cementite in a very finely divided form. Several of the stages in the resolution of the solid solution lead to the production of such characteristic microscopic structures that distinct metallographic names have been given to them; but as none of these represent conditions of stable equilibrium, they are not included in the diagram.

The stages generally recognized are—

Austenite—martensite—troosite—[osmondite]—sorbite—pearlite.

They will be described together with the other micrographic constituents of the iron-carbon alloys.

The facts that slowly cooled cast-iron contains practically the whole of its carbon in the form of graphite, and that cementite, or iron rich in cementite, deposits carbon when heated, are well known, but do not receive recognition in the equilibrium just described. An important series of experiments led to the conclusion¹ that the final equilibrium of the system, only reached after a very prolonged annealing, was one between the two solid phases ferrite and graphite. The suggestion was then made that two systems, a stable and

¹ G. Charpy and L. Grenet, *Bull. Soc. d'Encouragement*, 1902, 399. *

a metastable, should be represented in the diagram,¹ and this representation has been adopted by the majority of metallurgists, although open to considerable objection.

In the metastable system, the phases separating from the liquid alloy are austenite and cementite, as described above. In the stable system, on the other hand, they are austenite and graphite. The eutectic point lies somewhat above that of the metastable system, but not far from the same percentage of carbon. The curve AF, representing the crystallization of austenite, is the same in both systems. The graphite curve, FG, is placed somewhat above the cementite curve, CB, and the carbide system is thus represented as being produced by the undercooling of the graphitic system, AF being prolonged to C. The supposed curves of the stable system are here drawn as dotted lines.

According to Goerens, solidification never takes place according to the scheme indicated by the dotted lines.² This investigator concludes from his experiments that undercooling always takes place at least as far as the eutectic point, and that the liberation of graphite is always due to the dissociation of the cementite first formed. Benedicks and others have found a solubility for graphite in γ -iron corresponding with the dotted curve HP.³ This conclusion is reached principally as the result of measurements of the extent to which iron can dissolve graphite at different temperatures, and is open to the objection that in such cases an intermediate formation of cementite may take place. It is certainly a suspicious circumstance that the curves AF, FG, HF, and HP coincide almost exactly with AC, CB, EC, and ES, respectively, and this fact alone leads to some hesitation in accepting the proposed scheme of stable and metastable equilibria.⁴ The hypothesis of an equilibrium between graphite,

¹ G. Charpy, *Compt. rend.*, 1905, **141**, 948; E. Heyn, *Zeitsch. Elektrochem.*, 1904, **10**, 491.

² *Metallurgie*, 1907, **4**, 137.

³ G. Charpy, *Rev. de Métallurgie*, 1908, **5**, 77; R. Ruer and N. Iljin, *Metallurgie*, 1911, **8**, 97.

⁴ See p. 378.

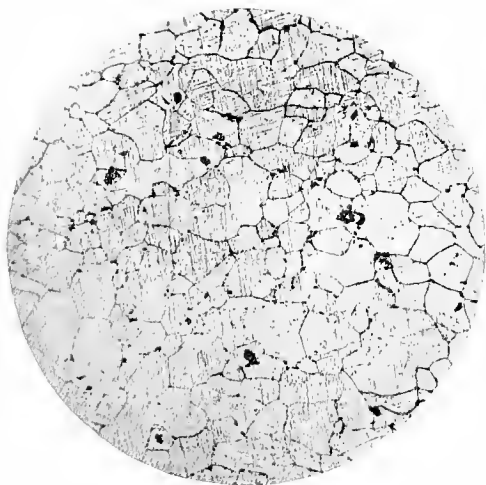

A. Soft iron, made by direct process. $\times 200$.



B. Soft steel. $\times 200$.

PLATE XIII.

[To face page 369.]

iron and carbide in solution, $\text{Fe}_3\text{C} \rightleftharpoons 3\text{Fe} + \text{C}$, has often been made, and may be used with some success to explain the phenomena.¹

We may now proceed to describe the microscopic appearance of the constituents enumerated in the diagram, and of the well-defined stages in the passage of steels from metastable to stable equilibrium.

Ferrite.—The name ferrite is given to α -iron. It forms the sole constituent of pure soft iron, and then occurs in polyhedral grains, the outlines of which are developed on etching, owing to minute differences of potential at the junction of neighbouring grains. Etching with picric acid produces a marked roughening of the surface, whilst nitric acid colours the grains, owing to the formation of oxide films. Different grains, owing to variations of orientation, become coloured unequally. If the iron is not quite pure, the impurities are commonly found at the edges, and especially in the angles, between adjacent grains. A specimen of nearly carbonless iron (a Japanese sword-guard, made by the direct process) is photographed in Plate XIII., A. Small quantities of slag are seen in the form of inter-crystalline enclosures, but with these exceptions, the specimen consists of pure ferrite.

Deep etching with acids, or with cupric ammonium chloride, reveals a cubic structure in ferrite. Attempts have been made to determine the crystallographic characters of γ - and β -iron by reducing crystals of ferrous chloride in hydrogen at temperatures above their respective transformation points.² As the result of such experiments, it has been found that γ -iron crystallizes in combinations of the cube and octahedron, whilst no difference could be detected between β - and α -iron, both of which crystallize in cubes. It must, however, be admitted that the crystallographic relations of the three modifications of iron are still obscure.

α -Iron containing silicon or other elements in a state of solid solution is indistinguishable from pure iron, and is

¹ See, especially, A. Smits, *Zeitsch. Elektrochem.*, 1912, 18, 51; O. Ruff, *Metallurgie*, 1911, 8, 456; H. M. Howe, *Trans. Amer. Inst. Min. Eng.*, 1912, 1181.

² F. Osmond and G. Cartaud, *Ann. des Mines*, 1900, [ix.] 18, 113.

therefore also considered as ferrite. Some solid solutions of this kind develop the cubical structure with remarkable perfection when etched deeply, and the best photo-micrographs of this sort have been obtained from iron containing silicon. It has been proposed that the micrographic constituent of alloys containing phosphorus, silicon, etc., should be called phospho-ferrite, silico-ferrite, etc.

The mechanical enclosures in ferrite (silicate slag and manganese sulphide) have been referred to in Chapter IX., and globules of the sulphide are seen in Plate XIII., B.

Graphite.—Graphite occurs in grey cast-iron in the form of large, thin plates, crystallizing in the hexagonal system. These plates are very commonly curved, the soft, plastic character of the graphite allowing it to yield to the pressures produced in the growth of the neighbouring ferrite crystals. The presence of both primary graphite, separating along the curve FG, and of eutectic graphite, formed at the point F, is rarely observed, owing, on the one hand, to the reluctance of the iron-carbon alloys to enter the state of stable equilibrium, and on the other to the low specific gravity of graphite, which causes it to float up to the surface of the solidifying mass. A good photo-micrograph, showing both the primary and eutectic graphite, was obtained by Goerens¹ from a grey iron containing 7 per cent. of graphite, prepared in the electric furnace.

Graphite is at once visible in the polished section, without etching. In specimens as ordinarily polished, without special precautions, the graphite is removed during the grinding process, and its place is represented by fine cavities. This is the usual result obtained in preparing sections of grey cast-iron.

Temper carbon is a finely divided form of graphite, produced in the decomposition of cementite, or of a solid solution of carbon in iron; it is therefore produced in the annealing of white cast-iron. It is commonly visible in the etched sections as minute aggregates, or "nests" surrounded by white areas of ferrite, due to the withdrawal of carbon from the surrounding

¹ *Metallurgie*, 1907, 4, 137.

alloy by segregation. Temper-carbon has been proved to be chemically identical with graphite.¹

Cementite.—The carbide, cementite, Fe_3C , is the only compound of carbon and iron which has yet been recognized by microscopical means. It is present in meteorites as cohenite.² A second carbide, Fe_2C , has been isolated by chemical means (see p. 377), and is present as chalypite in certain meteorites,³ but we are at present unable to distinguish the two compounds in micro-sections. Cementite crystallizes in large plates, apparently belonging to the hexagonal system,⁴ although cohenite is stated to be cubic.⁵ When seen in a micro-section the plates, being cut transversely, have the appearance of needles. In a white iron containing more than the eutectic proportion of carbide, the crystals are very well formed and regular, in annealed steels containing more than the eutectoid proportion they form more or less irregular bands arranged as cell walls enclosing areas of pearlite.

Cementite is not attacked by acid etching reagents, and remains brilliantly white when ferrite and pearlite have been darkened by etching. On the other hand, cementite is blackened by a boiling solution of sodium picrate in an excess of sodium hydroxidè, and this reagent is the most characteristic for distinguishing cementite from a solid solution. The hardness of cementite (6 on Mohs' scale) causes it to stand out in relief when the specimen is polished on a soft bed, and drawing a needle over the surface may also be employed as a means of recognition.

Pearlite.—The eutectoid mixture of ferrite and cementite is known as pearlite. In its most perfectly developed state, as seen in a slowly cooled steel, the two phases are arranged in parallel, slightly curved or wavy, lamellæ. If the annealing be prolonged, this arrangement, which is mechanically unstable, is changed into one in which the cementite forms granular

¹ G. Charpy, *Compt. rend.*, 1907, 145, 1173.

² E. Weinschenk, *Ann. Museum. Wien*, 1889, 4, 94.

³ C. U. Shepard, *Amer. J. Sci.*, 1867, [ii.] 43, 28.

⁴ Stated by Groth, *Chem. Krystallographie*, 1906, i., to be pseudo-hexagonal.

⁵ L. J. Spencer, *Min. Mag.*, 1902, 13, 296.

masses or oval globules, surrounded by areas of ferrite. This granular pearlite may be of all degrees of coarseness, the final stage being one in which the whole of the cementite is collected into a few isolated masses. Plate XI., B, shows pearlite which is granular in parts of the field, but chiefly lamellar. An interesting intermediate form has been observed, the cementite presenting itself as lamellæ, which appear continuous under a low power, but under higher magnification resolve themselves into series of globules, resembling strings of beads.¹ This "beady" pearlite represents the first stage in the transition from lamellar to granular pearlite.

Pearlite is more readily etched by acid reagents than ferrite, so that it appears as dark patches when an annealed steel is etched and examined under a low magnification. When more highly magnified, it is seen that only the ferrite lamellæ are darkened. Polishing in relief, or polishing by Osmond's polish-attack method, also brings out the cementite lamellæ on a dark ground. In Plate XIII., B, representing a low-carbon steel, the pearlite appears as black patches, being unresolved at the low magnification adopted. The laminated structure is the cause of the pearly lustre of the etched or relief-polished surface which has gained for pearlite its name.

The cementite of pearlite, as ordinarily obtained, appears to be identical with structurally free cementite, chemical analyses of the two being identical.² The question whether the ferrite constituent is identical with structurally free ferrite is not so easily solved. The fact that ferrite, when forming a constituent of pearlite, is much more rapidly etched than when free, suggests a chemical difference, although it is possible to explain it as due to the local electrolytic influence of the cementite. Benedicks concludes from the density, magnetic properties, etc., of steels, as well as from the micro-structure, that a solid solution of carbon in β -iron, containing up to 0.27 per cent. C, is present in pearlite, and to this constituent he gives the name of *ferronite*. The existence of ferronite as a

¹ C. Benedicks, *Metallurgie*, 1909, 6, 567.

² A. Ledebur, *Stahl u. Eisen*, 1887, 8, 742; 1891, 11, 294.

distinct phase has not received general acceptance from metallographists.

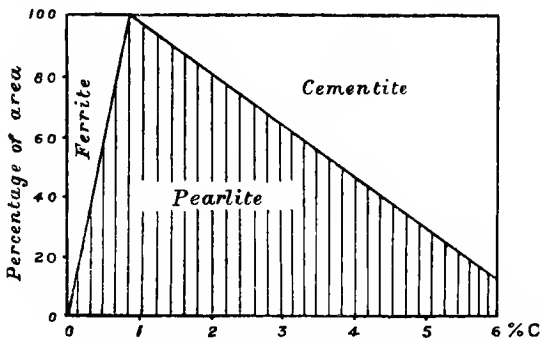

FIG. 106.—Micrographic constituents of steels.

Austenite.—The term austenite has been variously employed in the past, but its use is now confined to the solid solution formed in the solidification of iron-carbon alloys. It therefore consists essentially of a solid solution of iron carbide in γ -iron, but other elements may also be present in a dissolved state without altering its nature. It has not been found possible to prepare pure austenite by quenching a pure iron-carbon alloy, a certain amount of transformation taking place while passing through the critical range, however rapidly the quenching is carried out. The stability of austenite is, however, greatly increased by the presence of manganese, and the pure constituent has been obtained¹ by quenching a steel containing 0.93 per cent. C and 1.67 per cent. Mn from 1050° in ice-water. Steels containing 13 per cent. Mn or 25 per cent. Ni (manganese or nickel steels) consist of pure austenite.

Homogeneous austenite forms polygonal grains, frequently twinned, and resembling in general appearance an annealed brass. When growing freely, its crystals are regular octahedra. It is very soft, being little harder than ferrite, and is non-magnetic. As it occurs most frequently in the form of mixtures

¹ E. Maurer, *Metallurgie*, 1909, 6, 33.

with martensite, its metallographic behaviour will be described under the next heading.

The austenitic structure of steels at a high temperature may be revealed by etching with gaseous hydrogen chloride at 1120° , even in the absence of manganese.¹

Martensite.—This is the principal constituent of iron-carbon alloys hardened by rapid quenching. It is the essential constituent of hard steels, and is the cause of their hardness. It represents the first stage in the resolution of austenite during cooling into α -iron and cementite. A quenched, but untempered, tool-steel shows the structure well. When etched with picric acid, it is resolved into systems of very straight, parallel lines, forming three systems intersecting at angles of 60° . These lines, often described as needles, really represent cleavages of octahedra. Long supposed to be homogeneous, and to represent the original solid solution stable above the transformation point, the recent researches on austenite have proved that martensite is a product of partial resolution, and that the etching reveals a heterogeneity of structure. Martensite contains α -iron, and is therefore magnetic, but the constrained molecular condition gives it a high coercive force. It is the essential constituent of permanent magnets.

A steel containing 1.6 per cent. C, quenched from 800° in ice-water, consists of cementite, in a ground-mass of pure martensite, whilst the ground-mass of the same steel, quenched from 1100° , consists of a mixture of austenite and martensite. In such mixtures, the martensite forms characteristic, angular crystals, designated "fers de lance" by Osmond. The behaviour of these crystals on etching is variable. Sometimes they appear black on the white background of austenite, at other times the austenite is etched more rapidly than the martensite. Kurbatoff's complex reagents produce better contrasts than the simple acids commonly used for etching. A needle may also be used to distinguish austenite from martensite, the greater hardness of the latter being very marked. The different behaviour on etching is frequently due to the

¹ Baykoff, *Rev. de Métallurgie*, 1909, 6, 829; N. J. Wark, *Metallurgie*, 1911, 8, 731.

partial conversion of one or other of the constituents into troostite.

Austenite is partly converted into martensite by cooling in liquid air,¹ a polished surface after such treatment being marked with "fers de lance" in relief, or the same change may be brought about, to a limited extent, by cold-working, that is, by mechanical deformation at the ordinary temperature.

Troostite.—This constituent, frequently present in hardened steels, especially after partial tempering, is characterized by the deep brown or black surface tint produced by etching, especially with reagents containing nitro-compounds. It commonly presents itself as nodules, or as a border invading crystals of austenite or martensite. Various suggestions have been made to explain the nature of troostite. The hypothesis that it is β -iron, free from carbon,² may be at once rejected, whilst the view that it consists of a solution of elementary carbon in iron,³ austenite being a solution of carbide, is also without evidence in its favour. The physical and chemical properties of troostite all indicate that it is a mixture of cementite and ferrite, only differing from pearlite in its extremely fine state of division. Benedicks describes it as a colloidal solution of carbide in iron.⁴ It was described by Arnold as "emulsified carbide,"⁵ a term which also expresses the fine state of subdivision. It may be obtained in an almost pure condition by quenching steel containing 0.9 per cent. of carbon from 725° with suitable rapidity. The coalescence of the carbide particles to form pearlite takes place rather sharply at 400°. The fine state of division is sufficient to account for the readiness with which carbon is liberated from it by the action of etching reagents. The darkening of austenite or martensite in tempered specimens is due to partial conversion into troostite.

¹ F. Osmond, *Étude des Alliages*, 296; E. Maurer, *loc. cit.*

² H. C. Boynton, *J. Iron Steel Inst.*, 1904, i. 262.

³ W. A. Kurbatoff, *Rev. de Métallurgie*, 1905, 2, 169. See also F. Rogers, *J. Iron Steel Inst.*, 1905, i. 484.

⁴ *Ibid.*, 1905, ii. 352; 1908, ii. 217; *Kolloid Zeitsch.*, 1910, 7, 290.

⁵ J. O. Arnold, *Proc. Inst. Civ. Eng.*, 1895, 123, 127.

Osmondite.—Heyn and Bauer¹ have given the name osmondite to a stage intermediate between troostite and sorbite, and forming the boundary between these two structures. They were led to adopt a distinct name by their observation that the passage of martensite into pearlite on heating takes place in such a way that the transformation has a maximum value at 400°. Steel heated to this temperature has a maximum rate of solution in sulphuric acid. The quantity of carbon which is liberated in the elementary state on dissolving in 10 per cent. sulphuric acid (as distinguished from that which is liberated as carbide) increases from martensite through troostite to osmondite, and then diminishes on passing from osmondite through sorbite to pearlite. No characteristic microscopic structure is, however, observed, and it therefore seems superfluous to distinguish the boundary between troostite and sorbite by a new name.

Sorbite.—Sorbite differs only in its minutely granular structure from pearlite. It becomes coloured like pearlite by etching reagents, but higher magnification reveals nothing but a finely granular structure. Structural steel contains more sorbite than laminated pearlite, the former being accompanied by better mechanical properties. In a white iron, such as that shown in Plate XIV., A and B, the original crystallites of austenite have been converted during cooling into sorbite, which appears dark and structureless in the photograph.

THE TECHNICAL VARIETIES OF STEEL AND CAST IRON

The structure of steels in an annealed condition may be determined from Fig. 106. The area of pearlite in a photomicrograph increases rapidly with the proportion of carbon up to 0.9 per cent., and then diminishes more slowly. The pearlite in very low-carbon steels forms small areas between the ferrite grains, but as its proportion increases a different structure appears, and the ferrite forms a network, enclosing the areas of pearlite. The size of mesh of this network is an indication of the size of the grains of austenite existing at a high temperature before the transformation took place.² In

¹ *J. Iron Steel Inst.*, 1909, i., 109.

² H. M. Howe, *Internat. Zeitsch. Metallographie*, 1912, 2, 13.

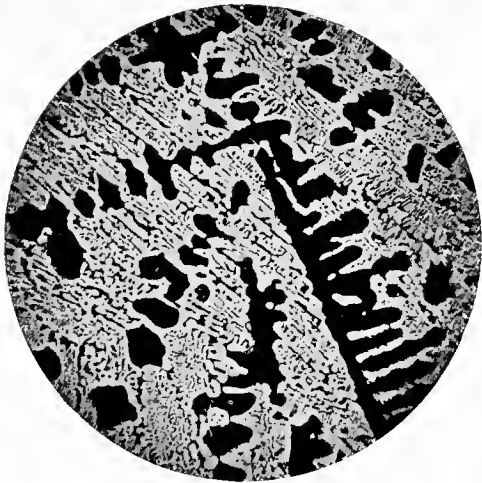

A. White pig iron. $\times 86$.

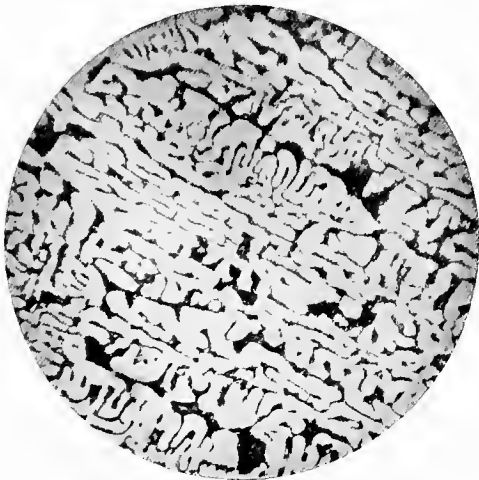

B. Eutectic of white pig iron. $\times 200$.

PLATE XIV.

[To face page 376.]

hyper-eutectoid steels, the cementite forms a similar network, the structure in both cases being due to the deposition of the constituent in excess at the borders of the grains during cooling. Much information as to the rate of cooling may be derived from a study of the thickness of the borders in any given case.

The structure of hardened steels is too complex to be discussed here in any detail. Reference may be made to a useful review of the subject from the physico-chemical point of view.¹ The view there maintained, however, that the difference between the constituents austenite and martensite is merely due to twinning under the influence of pressure, is not generally accepted, and is open to many objections. The conditions under which different structures occur have been briefly indicated under the headings of the respective constituents.

White cast-iron owes the principal features of its structure to the presence of the austenite-cementite eutectic, the appearance of which is shown in Plate XIV., B. If the proportion of carbon is less than 4.3 per cent., the eutectic is accompanied by crystal skeletons of primary austenite, as shown in Plate XIV., A. During cooling, these austenite masses undergo resolution, and generally appear as dark masses of sorbite after etching, but their outline remains that of the primary austenite. Needles of secondary cementite, thrown out of solid solution along the curve ES (Fig. 105) are often to be seen in the dark mass of sorbite.

On the other hand, white iron containing more than 4.3 per cent. of carbon shows large plates of primary cementite in addition to the eutectic. An iron containing exactly the eutectic proportion of carbon frequently exhibits a cleavage suggestive of large crystal plates, although free cementite is absent. This effect is due to the tendency of this eutectic already noted (p. 185) to form "colonies" of definite parallel orientation.

Grey cast-iron contains, as its principal constituents, pearlite, graphite, and either ferrite or cementite, according as the proportion of combined carbon is below or above the

¹ C. A. Edwards, *J. Iron Steel Inst.*, 1910, ii. 147.

eutectoid proportion. A further constituent, which is rarely absent from the commercial varieties of grey iron, is the eutectic of iron and iron phosphide, Fe_3P , which forms reticulated masses, brilliantly white in an etched specimen, and appearing as distinct islets of hard material in the softer ground-mass.

A MODIFIED EQUILIBRIUM DIAGRAM

It must be admitted that the assumption of a metastable and a stable equilibrium of iron and carbon, coinciding almost exactly in the higher range of temperature, is far from satisfactory. It has, nevertheless, been adopted by the majority of metallographists as the best available expression of the facts. A provisional hypothesis has recently been proposed,¹ which avoids many of the difficulties of the double diagram. Upton provides for the inclusion of cementite in the stable system, whilst confining its stability to a range of temperature limited in both directions. The following facts, neglected by other investigators, have been utilized:—

1. The thermal observations of Carpenter and Keeling² show arrests in almost all the alloys examined, at 800° and a little above 600° respectively. Attempts have been made to explain away these arrests, but there is every reason to suppose them to be real.

2. Cementite decomposes above 800° , setting free graphite.³ Even after prolonged heating at 900° , a part of the carbon remains combined or dissolved, amounting to about 3.6 per cent.⁴

3. Long annealing of cementite below 600° leads to the formation of a higher carbide, which may be separated

¹ G. B. Upton, *J. Physical Chem.*, 1908, 12, 506; 1909, 13, 388.

² *J. Iron Steel Inst.*, 1904, i, 224.

³ F. Mylius, F. Foerster, and G. Schoene, *Zeitsch. anorg. Chem.*, 13, 38; *Ber.*, 1896, 29, 2991; J. O. Arnold and A. A. Read, *Trans. Chem. Soc.*, 1894, 65, 788.

⁴ E. H. Saniter, *Metallographist*, 1902, 5, 215.

mechanically and chemically. The formula of this carbide appears to be Fe_2C .¹

4. The iron in equilibrium with graphite in grey cast-irons can hardly be pure ferrite, its magnetic susceptibility, allowance being made for the graphite present, being far below that of pure iron.

5. The combined carbon in slowly cooled cast-iron is increased by heating between 800° and 1000° .² This is contrary to the view that cementite is metastable at all temperatures.

6. The brittleness produced in steels by heating at $500\text{--}550^\circ$ ³ indicates a change of constitution at a low temperature.

Utilizing these and other facts of observation, Upton has constructed the diagram shown in Fig. 107. The liquidus and solidus, and the transformations of steels containing less than 0.89 per cent. C, remain as before. The only solid phases separating from the liquid, under conditions of equilibrium, are graphite and a solid solution of carbon in γ -iron, here denoted by I. Below the solidus, there is a small range of temperature within which these are the stable phases. At about 1095° , they react to form a carbide containing 3.5 per cent. C, and therefore represented by the formula Fe_8C . Upton suggests that this may be only a solid solution, and not a definite compound; but this would involve a considerable modification of the diagram, as in that case the transformation line at 800° could not be horizontal, but must have a considerable inclination. At 800° , the carbide constituent gives up a part of its iron, and passes into cementite, and at 615° a further quantity of iron, now transformed into the α modification, is given up, and the stable carbide Fe_2C is formed. The last reaction proceeds very slowly, and equilibrium is not attained until after prolonged annealing.

¹ E. D. Campbell and M. B. Kennedy, *J. Iron Steel Inst.*, 1902, ii. 288; C. Benedicks, *op. cit.*

² E. Heyn and O. Bauer, *Mitt. k. Mat.-Prüf. Amt.*, 1906, 24, 29; *Stahl u. Eisen*, 1907, 27, 1565; G. P. Royston, *J. Iron Steel Inst.*, 1897, i. 166.

³ J. E. Stead, *J. Iron Steel Inst.*, 1898, i. 145; ii. 137; C. E. Stromeyer, *ibid.*, 1907, i. 200.

Undercooling readily takes place in the solidification of the molten cast-irons, so that the left-hand branches of the liquidus and solidus are prolonged into the Fe_3C region. The structure

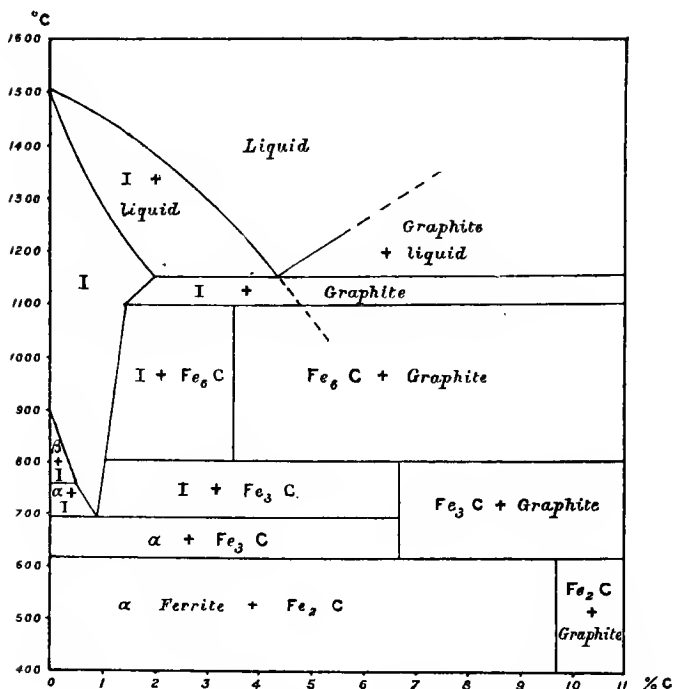

FIG. 107.—Upton's diagram of the iron-carbon alloys.

of white cast-irons, on this assumption, is due to the presence of crystals of I (white) and masses of undercooled mother-liquor (dark on etching). This is the weakest point in Upton's explanation, for it is difficult to believe that the beautifully defined structure found in white cast-irons (Plate XIV., A and B) is not a true eutectic.

When the white iron is annealed, the first reaction is assumed to be that which was suppressed during solidification, namely,

the formation of graphite. Hence the production of temper carbon. Further heating at temperatures below 1095° should cause the re-solution of a part of this carbon. The statement of Goerens and Gutowsky, that all graphite produced in or near the freezing range is formed by the decomposition of cementite, is denied, and it is affirmed that the parent substance is in all cases a solid solution (austenite or I) and not cementite. A thorough investigation of the microscopic structure, using reagents capable of distinguishing between cementite and supersaturated austenite or its decomposition-products, is desirable. Means of distinguishing the three supposed carbides have also to be devised.

A complete discussion of the proposed diagram is impossible in the space available. Whilst the scheme is clearly defective in some respects, it represents a bold and original attempt to solve a difficult problem, and contains some features which will almost certainly be incorporated in the complete diagram of future metallographists. Further suggestions for a modified diagram are given by A. Kroll¹ in a memoir which contains important new facts.

THE INFLUENCE OF OTHER ELEMENTS ON THE IRON-CARBON SYSTEM

Commercial varieties of iron and steel commonly contain other elements besides iron and carbon, frequently in notable proportions. The addition of a third element may affect the equilibrium of iron and carbon in several ways. In the first place, the tendency of the alloys to assume the metastable (carbide) form rather than the stable (graphitic) form depends to a great extent on the presence of other elements. Silicon greatly accelerates the separation of graphite, whilst manganese and sulphur favour the retention of carbon in the combined

¹ *J. Iron Steel Inst.*, 1910, i. 304.

form.¹ The quantitative relationships have been most fully worked out in the austenite-cementite series, and the conclusion has been reached that two principal types of ternary systems present themselves.²

1. The third element forms solid solutions with γ -iron, and also enters into the solid solutions containing cementite. Equilibria of this kind are obtained with Mn, Si, Cr, Ni, and W.

2. The third element forms a compound with iron, which has only a small solubility in solid γ -iron, and is insoluble in cementite. A ternary eutectic is therefore formed. Examples of this type are furnished by P, As, Sb, and Sn.

Manganese may be taken as a typical representative of the first class. Manganese is isomorphous with γ -iron, and austenite is in fact best obtained by quenching iron containing manganese (p. 373). Manganese carbide, Mn_3C , is isomorphous with Fe_3C , which it closely resembles. The structure of a white cast-iron is thus unchanged by addition of manganese, and the freezing-point curve is only slightly modified, the general form remaining the same. The exceedingly tough manganese steel manufactured contains 12-13 per cent. Mn and about 1 per cent. C.³ Alloys containing so large a quantity of manganese do not undergo transformation to pearlite on cooling, that is, austenite rich in manganese is stable even at the ordinary temperature.⁴

In the iron-carbon-silicon alloys, two series of solid solutions are formed, one being an austenite containing carbon and silicon dissolved in γ -iron, and the other a solution of Fe_3C and Fe_2Si .⁵

The behaviour of alloys containing phosphorus is very different.⁶ The ternary system $Fe-Fe_3C-Fe_3P$ resembles such

¹ The factors for calculating the displacement of graphite by other elements have been worked out by M. Orthey, *Metallurgie*, 1907, 4, 196.

² P. Goerens, *Metallurgie*, 1909, 6, 531, 537.

³ R. A. Hadfield, *Proc. Inst. Civ. Eng.*, 1888, 93, iii, 1.

⁴ L. Guillet, *Compt. rend.*, 1908, 146, 74; F. Wüst, *Metallurgie*, 1909, 6, 3. The structure of the ternary alloys of iron and carbon has been investigated by L. Guillet, and summarized in *Rev. de Métallurgie*, 1905, 2, 350.

⁵ W. Gontermann, *Zeitsch. anorg. Chem.*, 1908, 59, 373.

⁶ J. E. Stead, *J. Iron Steel Inst.*, 1900, ii, 109; P. Goerens and Doppelstein, *Metallurgie*, 1908, 5, 561; F. Wüst, *ibid.*, 73.

a simple system as that of lead, tin, and bismuth. γ -Iron dissolves about 2 per cent. C and 2 per cent. P, but iron carbide and phosphide are mutually insoluble. There are thus three binary eutectics (austenite-cementite, austenite-phosphide and cementite-phosphide) and a ternary eutectic point, at which all three solid phases are in equilibrium. The latter point lies at 953° and 91.3 per cent. Fe, 2.0 per cent. C, and 6.7 per cent. P. Arsenic, antimony, and tin form similar systems.¹

The effect of these added elements on the transformations of carbon steels below the solidus is naturally exceedingly complex, and the metallography of the ternary and quaternary steels, many of which have great technical importance, has already become the subject of several special treatises.²

METEORIC IRONS

We may conclude this chapter with a brief account of the metallography of the specimens of iron and its alloys of extra-terrestrial origin, known as meteoric irons, or as meteorites. The historical interest of this branch of the subject is considerable, for it was in the study of meteorites that the plan of examining polished and etched surfaces was first introduced by Widmanstätten, and it was from the same study that Sorby was afterwards led to investigate the behaviour of terrestrial iron and steel under similar treatment.³

The principal meteoric irons are composed of iron and nickel. They may be either octahedral or cubic in crystalline structure. Considering the octahedral irons first, a coarse structure is readily developed by etching or heat-tinting. Three principal constituents are observed :—

Kamacite is a solid solution of α -nickel in α -iron, containing 6–7 per cent. Ni, and forms thick plates, built up of cubes twinned on the fluorite plan. Cubic meteoric irons consist wholly of unsaturated kamacite. Neumann's lines appear in kamacite after mechanical deformation.

¹ P. Goerens and K. Ellingen, *Metallurgie*, 1910, 7, 72.

² See, for instance, L. Guillet, *Les Aciers Spéciaux*, Paris, 1908.

³ See p. 3.

Taenite is a solution of iron in α -nickel, containing 13-35 per cent. Ni.

Plessite has a duplex structure, and is obviously a eutectic or eutectoid mixture of kamacite and taenite. The particles may be intermixed, or they may reproduce, on a small scale, the general octahedral structure of the meteorite.

The problem presented by these alloys is that of reconciling their structure with that of terrestrial alloys of iron and nickel. These metals form solid solutions, γ -iron being isomorphous with β -nickel, and α -iron with α -nickel. The transformation is not reversible for all the alloys, a considerable lag of temperature (temperature hysteresis) being observed in alloys containing from 0 to 25 per cent. Ni; but the microscopic structure is in all cases homogeneous, the alloys being composed wholly of polyhedra. Osmond and Cartaud considered that a eutectoid point existed at 25 per cent. Ni (Fig. 108), and that the absence of any corresponding structure in the artificial alloys was due to the comparatively rapid cooling of the specimens.¹ It was observed, however,² that certain meteorites had a granular, instead of the usual orientated, structure, and that normal meteorites could be rendered granular by heating to 950°. Following up this clue, it was found that the structure of meteorites could be destroyed by annealing.³ Octahedral irons, packed in magnesia enclosed in a layer of reduced iron, heated to 800°, showed granulation in the kamacite area after 1 minute, and after 15 hours at 1000° the plessite and taenite had almost completely disappeared, and the kamacite had become granular throughout. The complex structure was in this way converted almost completely into the polyhedra characteristic of the terrestrial alloys.

The octahedral structure of the irons, whatever be its nature, must have arisen from crystallization in a solid solution, for the uniform orientation throughout a large specimen is inconsistent with crystallization from the liquid

¹ *Rev. de Métallurgie*, 1904, 1, 69.

² F. Berwerth, *Sitzungsber. h. Akad. Wiss. Wien*, 1905, 114, i. 345; F. Rinne and H. E. Boecke, *N. Jahrb. Min.*, 1907 [Festband], 254.

³ W. Fraenkel and G. Tammann, *Zeitsch. anorg. Chem.*, 1908, 60, 416.

state. These experiments, and others of a similar character, led to the conclusion that the structure of meteoric irons was an unstable one, and that the final state of equilibrium was one of homogeneous solid solution. It has now, however, been shown that these results are to be explained by the fact that the temperature of annealing lay far above the eutectoid

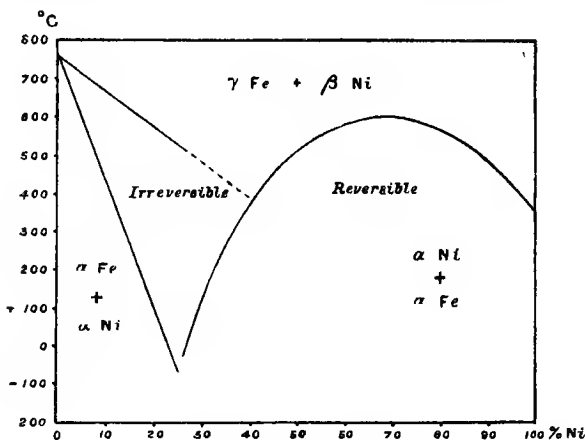

FIG. 108.—Iron-nickel alloys.

point. When an alloy of iron with 12 per cent. of nickel is prepared by the aluminothermic process, and is cooled very slowly from 350° to the ordinary temperature, plessite is formed, and the structure of the octahedral irons is reproduced.¹ The difficulty experienced in obtaining a structure similar to that of the natural iron is accounted for by the very low velocity of diffusion in the solid solution below 350° .

¹ C. Benedicks, *Rev. de Métallurgie*, 1911, 8, 85.

CHAPTER XVIII

THE METALLOGRAPHY OF INDUSTRIAL ALLOYS

THE possible types of structure encountered in the laboratory study of alloys are extremely numerous, but only a limited number of these possess properties which render the alloys suitable for technical application. Many structures of metallographic interest are associated with great mechanical weakness, rendering the alloys unfit for any purpose involving resistance to mechanical stress, whether gradually or suddenly applied. Inter-metallic compounds, and the solid solutions which they form with their components, are in general too hard and brittle to find technical application except in a few special cases, as, for instance, when a brilliant, mirror-like surface is required, as in speculum metal. Resistance to shock is not demanded in such a case, and the extreme brittleness of the alloy is therefore no disadvantage. Occasionally a certain appearance or colour is required for decorative purposes, as in jewellery, and other properties may be comparatively unimportant.

A large proportion of the alloys employed for constructional purposes, and therefore required to possess certain physical and mechanical properties, fall into a few well-defined groups. For instance, amongst the alloys of copper with other metals, the α solid solutions, which consist of copper holding a second metal in a state of solid solution in quantities insufficient to saturate it, are some of the most important of industrial alloys. Whether the second metal be zinc, tin, aluminium, nickel, iron, or manganese, the resultant alloys, within certain limits of composition, bear a close resemblance to one another. The

microscopic structure is in all cases the same, that of a crystalline solid, built up of polygonal grains which are homogeneous if slowly cooled or annealed, but exhibit a "cored" structure if cooled too rapidly for the attainment of equilibrium. Mechanically, all these alloys are characterized by toughness and malleability, in degrees which naturally vary with the nature and quantity of the added metal.

A second type of structure, due to the separation of a micrographic constituent from solid solution during cooling, also presents itself in several instances among the copper alloys. This " $\alpha\beta$ " structure is very characteristic, and the resemblance between alloys of this type containing different metals is often very close, so that an alloy of copper containing 8 per cent. of aluminium, for instance, is almost indistinguishable in appearance, so far as the arrangement of the α and β phases in the micro-section is concerned, from one containing 42 per cent. of zinc. Here, again, the similarity of structure corresponds with a marked similarity of properties.¹

In this chapter, some of the more important alloys which find industrial application are briefly reviewed. An entirely systematic arrangement has not been adopted, so that whilst the grouping is generally according to chemical composition, alloys of different composition have occasionally been grouped together, if the similarity of their application seemed to render such an arrangement convenient. The list of alloys mentioned below could be extended indefinitely did space permit, but the principal types of structure at least receive mention.²

Copper-zinc.—The industrial alloys of copper and zinc fall, with a few unimportant exceptions, into two classes, those composed of the α solution only, and those built up of the α and β phases in conjunction. The first group includes the brasses, and the second Muntz's metal and similar alloys.

Of the brasses, an alloy containing 33 per cent. Zn is

¹ The resemblance is even closer than at first appears. The β -solution in the case of the alloys of copper with tin and with aluminium is resolved into two phases at low temperatures, and it has now been shown that a similar condition occurs in the alloys of copper and zinc (see p. 62).

² The composition of a large number of industrial alloys is tabulated by W. Kaiser, *Metallurgie*, 1911, 8, 257, 296.

commonly used for casting purposes, whilst the maximum ductility is possessed by the alloy containing only 30 per cent. Zn. The latter mixture is capable of withstanding extremely severe mechanical deformation, and is therefore employed in the production of tubes and wires by drawing through dies at the ordinary temperature. The destruction of crystalline structure in the drawing process is very extensive, and the formation of the amorphous modification gives rise to such an increase of hardness and brittleness that it is necessary to carry out the reduction in thickness in a number of successive stages, restoring the crystalline structure by annealing after each reduction. The formation of a cartridge-case from a disk by pressing between dies is a typical example of the severe mechanical treatment applied to a 70 : 30 brass. The microscopic structure of such a worked metal is highly confused, the α crystals being broken down and thrust into and through one another by the pressure. The annealing is best performed at 600–650°, when recrystallization takes place. Twinned α crystals are abundantly produced, and the size of the crystals increases both with the temperature and with the duration of the annealing process.¹ The “burning” of brass above 750° is probably due to volatilization of zinc from the α phase. The α crystals are homogeneous throughout, “cores” only being observed in the cast metal, and disappearing completely after working and annealing. An example has been shown in Plate II., B. Lead is often added to cast brass to render it easier to cut or turn; it is recognizable under the microscope as isolated globules, mechanically retained by the solidifying metal, and not truly alloyed.

The second group of copper-zinc alloys comprises those containing from 36.5 to 46 per cent. of zinc, and made up, when in a state of equilibrium, of the α and β solid solutions. From the diagram (Fig. 29), it will be seen that the β region is of peculiar form, narrowing considerably as the temperature falls.² A number of alloys, therefore, composed after solidification

¹ See, for the mechanism of annealing in these and similar alloys, G. D. Bengough and O. F. Hudson, *J. Inst. Metals*, 1909, 1, 89.

² E. S. Shepherd, *J. Physical Chem.*, 1904, 8, 421; V. E. Tafel,

entirely of β crystals, become heterogeneous at lower temperatures, either the α or the γ phase crystallizing out, according to the composition. Alloys containing the γ phase in excess, even in small quantity, are devoid of technical importance, the γ crystals, which appear to consist of the compound Cu_2Zn_3 , being extremely hard and brittle.

Muntz's metal, containing 40 per cent. Zn, is composed of α and β crystals, but may be obtained in the form of homogeneous β crystals by quenching from temperatures above 750° . The structure of a rolled bar of Muntz's metal is seen in transverse section in Plate IX., A, in which the light areas represent the α constituent and the dark the more readily etched β constituent. If slowly cooled through the transformation range, the α crystals assume characteristic forms, and the structure is then almost indistinguishable from that of the aluminium bronze shown in Plate VIII., B.

The β constituent gives to alloys in which it occurs the property of being ductile at a higher temperature, so that Muntz's metal, unlike brass, may be rolled hot. On the other hand, the β crystals, or the mixture of ultramicroscopic particles of α and γ , are less ductile at the ordinary temperature than the α . Muntz's metal quenched from above 750° is therefore harder and stronger, but less ductile, than the annealed alloy.

The effect of small additions of a third metal on the structure and properties of the $\alpha\beta$ alloys has been already referred to in connection with the work of Guillet (page 191). An alloy containing 37 per cent. of zinc and 1 per cent. of tin is used under the name of *naval brass*, on account of its superior resistance to the corrosive action of sea-water. This quantity of tin is entirely held in solid solution, and is not microscopically recognizable. An alloy of similar structure, containing about 40 per cent. of zinc, and 1 per cent. or rather more of iron, is used in engineering under the name of *Delta metal*. In this case also, the iron is held in solid solution. Small additions of aluminium, silicon, and manganese are also

Metallurgie, 1908, 5, 343. See also G. Charpy, *Étude des Alliages*, 1901, 1. A eutectoid is formed, but the finely dispersed, ultramicroscopic mixture of α and γ is relatively very stable, and does not exhibit segregation unless an excess of either α or γ is present.

made with the object of improving the mechanical properties of the alloys of this group, while leaving the $\alpha\beta$ structure intact. They are known collectively as *special brasses*, and separately as aluminium brass, etc., although such erroneous designations as manganese bronze, etc., properly belonging to quite different alloys, are in frequent use.¹

Copper-tin.—Here, again, the first important series of alloys consists of α solid solutions, comprising those mixtures containing up to about 12 per cent. of tin. The structure of such alloys is unaffected by quenching. The best gun-metals contain from 8 to 10 per cent. Sn, and therefore fall within the limits of this group; they are characterized by great strength, elasticity, and toughness.

In the microscopical examination of bronzes, crystals of stannic oxide are often observed, mechanically enclosed in the alloy, and representing a serious source of weakness. Such enclosures are evidence of defective melting and casting. Re-melting is frequently resorted to as a means of eliminating this impurity.

Bronzes containing more than 12 per cent. Sn are also employed. As will be seen from the equilibrium diagram (Fig. 98), their structure depends on the heat-treatment they have received. Above 500° they are composed of the α and β phases, a structure possessing great strength, and permitting forging at temperatures within the $\alpha\beta$ range. This structure can only be preserved by cooling rapidly from above 550° . Slowly cooled alloys of the same composition do not contain the β constituent, which breaks up, as described on p. 61, into the eutectoid complex of the α and δ phases, forming islands, bounded by a well-defined band of the hard, bluish-white δ constituent. This substance, sometimes regarded as a definite compound, Cu_4Sn , is a source of brittleness, and alloys containing it are weaker than those of the same composition, in which the $\alpha\beta$ structure has been preserved by

¹ The group which has been studied most thoroughly is that of the aluminium brasses. See H. C. H. Carpenter and C. A. Edwards, *Intern. Zeitsch. Metallographic*, 1912, 2, 209; M. Levi-Malvano and M. Marantoni, *Gazzetta*, 1911, 41, ii. 282.

quenching. The $\alpha\delta$ alloys containing up to 25 per cent. Sn are known as *bell-metal*, and possess great hardness and sonority.

Bronzes containing both tin and zinc find extensive application. In the construction of machinery, $\alpha\delta$ bronzes containing 10–18 per cent. of tin, and 2–4 per cent. of zinc, are used. Lead is often added to produce cleaner castings and to give greater facility in machining, but it is a serious source of weakness, remaining undissolved as inter-crystalline material, and thus greatly reducing the strength.¹ For statuary purposes, the percentage of zinc is as high as 5, that of tin being 5–8. The presence of zinc facilitates casting and modifies the colour. Lead is also added, the effect of this being not only to produce a highly fluid alloy, but to modify very greatly the oxidation film, or “patina,” which forms on the surface. Some Japanese and Chinese art bronzes, which assume a fine matt black patina, contain as much as 10–16 per cent. of lead, the brittleness thus produced being unimportant for the purpose of statuettes. The production of a patina, either by spontaneous oxidation in the air, or by treatment with oxidizing solutions, is a phenomenon of great interest, which has received very little attention from the scientific point of view. Very small quantities of foreign metals have a marked effect in modifying the colour of this surface layer, as in the case of the Japanese alloy *shakudo*, the fine patina of which is dependent on the presence of gold in quantities varying from 1 to 4 per cent. The purple or black surface coating is produced by “pickling” with a solution, consisting generally of copper sulphate and acetate.² The Japanese excel in the preparation of this kind of oxidized surface layer.

Bronze coins, which are required to take a sharp impression of the die and to possess sufficient hardness to resist the wear and tear of handling, are α solutions, consisting in this and most other countries of 95 per cent. Cu, 4 per cent. Sn, and 1 per cent. Zn.

Of alloys richer in tin, the only mixture of importance is *speculum metal*, formerly used in the construction of reflecting

¹ J. T. Milton, *J. Inst. Metals*, 1909, 1, 57, and discussion.

² W. C. Roberts-Austen, *J. Soc. Arts*, 1890, 38, 690.

telescopes, but now commonly replaced for that purpose by glass, coated electrolytically with silver or palladium. Speculum metal consists largely of the white, brittle δ constituent, associated with the α solution in small quantity, or, if containing more than 32 per cent. Sn, with the compound Cu_3Sn .

Copper-aluminium.—The aluminium bronzes are assuming a continually increasing industrial importance. As before, the α solid solution has good mechanical properties. It is the only constituent of alloys containing less than 7.3 per cent. Al, and the structure of such alloys is unaffected by quenching. When the proportion of aluminium is increased, alloys are obtained, the structure of which is dependent in the highest degree on the heat-treatment, the concentration of the solid solutions α and β varying with the temperature above 550° , and the β phase undergoing a change into α and γ at that point, as in the copper-tin alloys already referred to.¹ The strongest alloy of the series contains 10 per cent. of aluminium, and has a colour closely resembling that of gold. The mechanical properties of this alloy, and of those containing a slightly smaller quantity of aluminium, approach more nearly to those of steel than any other non-ferrous alloy. Mixtures containing the γ -constituent are brittle, but as this phase is produced only by long heating at 400° , alloys containing up to 11 per cent. Al may be employed at the ordinary temperature. The $\alpha\beta$ structure of the 10 per cent. alloy is shown in Plate VIII., B.

A few alloys at the other end of the range, containing only small quantities of aluminium, will be described under aluminium. Mixtures containing from 12–92 per cent. of aluminium are without industrial importance.

¹ The copper-aluminium equilibrium diagram is very complicated, and its form in the region 8–30 per cent. Al is still a matter of controversy. The most important papers are: H. C. H. Carpenter and C. A. Edwards, *Proc. Inst. Mech. Eng.*, 1907, 57, and discussion thereon; B. E. Curry, *J. Physical Chem.*, 1907, 11, 425; B. E. Curry and S. H. Woods, *ibid.*, 461; A. G. C. Gwyer, *Zeitsch. anorg. Chem.*, 1908, 57, 113; L. Guillet, *Rev. de Métallurgie*, 1905, 2, 567. The most careful determinations are those of Carpenter and Edwards, and of Curry.

Phosphor-bronze.—The addition of phosphorus to copper is practised for the purpose of removing oxygen from the molten metal. The quantity used must not exceed that required for complete deoxidation by more than about 0·1 per cent., a larger quantity causing brittleness, owing to the separation of hard particles of the phosphide, Cu_3P . Such a mixture is sometimes, very incorrectly, termed phosphor-bronze. The true alloys of this name consist of copper, tin, and phosphorus, the best composition being from 91–92 per cent. Cu, 7·4–8·7 per cent. Sn, and 0·3–0·6 per cent. P, except when used as a bearing metal, when a different structure is required. Malleable phosphor-bronze of the above composition is an α solution, and does not differ in structure from an ordinary gun-metal. The presence of phosphorus in solid solution hardens the metal, but does not otherwise affect the properties to any very marked extent. The improvement in quality of gun-metal containing a little phosphorus is to be attributed mainly to the complete removal of oxides.¹

Another class of phosphor-bronze alloys, employed in a cast state and not required to possess malleability, contains larger quantities of both tin and phosphorus, the former element being present to the extent of 10–15 per cent., and the latter to the extent of 0·7–1·5 per cent. Such alloys are very hard, and are able to resist friction; they are therefore employed in the manufacture of gear-wheels, bearings, etc. The hardness is due to the presence of the δ constituent of the copper-tin series, and of the hard copper phosphide Cu_3P . These two substances, forming isolated masses in the comparatively soft matrix of α solution, produce the combination of great hardness with a limited, but distinct, plasticity which is required for such purposes.

Other alloys of copper.—Several metals, capable of entering into solid solution in copper, yield alloys of industrial importance. *Nickel*, as has been shown on p. 48, is isomorphous with copper, and does not form a compound with it. The whole series, from pure copper to pure nickel, may therefore be regarded as consisting of the α solution. In accordance

¹ A. Philip, *J. Inst. Metals*, 1909, 1, 164.

with the general rule for solid solutions, the hardness increases very greatly towards the middle of the series, so that the alloys of greatest use are those containing comparatively small quantities of nickel. The alloy containing 2-3 per cent. Ni has been found valuable in locomotive work, having great toughness at the temperature of the fire-box. This property of resisting high temperatures without serious deterioration, is common to most of the α solutions of copper in which the quantity of added metal is not large. Of alloys richer in nickel, that containing 40 per cent. Ni has a low electrical conductivity, the temperature-coefficient of which is practically zero. As it is capable of being drawn into wire, it is largely employed in the construction of resistance coils, under the name of *constantan*.

Manganese also forms a continuous series of solid solutions with copper, the middle members of which are hard and somewhat brittle. The alloys containing 2-4 per cent. Mn are harder and tougher than copper, and like the alloys with nickel, retain their properties at comparatively high temperatures. The term "manganese-bronze," which should be retained for these alloys, is often improperly applied to copper-zinc alloys of the Muntz's metal type, to which small quantities of manganese, usually accompanied by iron, have been added with the object of removing oxygen and of conferring increased strength on the alloys, which should properly be termed "manganese brass." The true manganese bronzes are α solutions. *Iron* also forms α solutions with copper, characterized by great toughness and a hardness exceeding that of the pure metal. An alloy containing 82 per cent. Cu and 15 per cent. Mn, the remainder being nickel and iron, has a low electrical conductivity and almost zero temperature-coefficient, and is hence used for electrical resistance coils under the name of *manganin*. All the components are in a state of solid solution.

Ternary alloys of copper, zinc, and nickel, forming a single solid solution, are much employed under the names of *German silver* and various other trade designations. The most useful alloys of the series contain 50-60 per cent. Cu, 15-20 per cent.

Ni, and 20–30 per cent. Zn, but variations even beyond these limits are found. *Platinoid*, an alloy used in the construction of electrical resistances, is a German silver containing small quantities of tungsten.

Alloys of silver.—Silver, when employed for the purposes of coinage, or of the manufacture of silver articles, is always alloyed with a metal capable of entering into solid solution with it, in order to give increased hardness and resistance to wear. Sterling silver, used in the British coinage and for ornamental and other work bearing the hall-mark, consists of 92·5 per cent. silver, and 7·5 per cent. copper. The “fineness” of silver and gold being reckoned in thousandths instead of in percentages, sterling silver is said to be 925 fine. It is not a homogeneous solid solution, but consists of crystals of a solid solution rich in silver, separated by a eutectic (see Fig. 23, p. 57). This fact renders the alloys liable to separate during solidification, so that different portions of the ingot contain different quantities of the eutectic, a fact of great importance to the assayer.¹ Alloys containing only 90 per cent. Ag and even less, find application in jewellery. Cadmium is sometimes added in small quantities. The standards vary considerably in other countries.

The other alloys of silver are only of limited importance, the solid solution containing platinum being the only one of marked interest.

Alloys of gold.—Fine gold, being a very soft metal, is not in general use, and a hardening metal is almost invariably added. The added metal is either copper or silver, both of which form homogeneous solid solutions with gold. British standard gold contains 91·67 per cent. gold, and 8·33 per cent. copper (“22 carat” = $\frac{22}{24} = 91·67$ per cent.), and this is the composition employed in coinage, whilst most of the alloys used for the manufacture of jewellery contain larger quantities of the hardening metal. Silver may take the place of copper, yielding alloys of paler colour. In both cases the structure is homogeneous.

¹ W. C. Roberts (afterwards Roberts-Austen), *Proc. Roy. Soc.*, 1875, 23, 481.

Alloys of aluminium.—The great lightness of aluminium has led to the desire to introduce its use as a structural metal in motor-cars and other machines in which the saving of weight is aimed at, but its comparatively poor mechanical properties, and the difficulty of obtaining sound castings, have proved to be obstacles to its use. Solid solutions, of which aluminium is the principal constituent, have given much better results in practice, and are now extensively employed. These so-called "light alloys" contain up to 20 per cent. of zinc, 6 per cent. of copper, or 5 per cent. of nickel, or proportionate quantities of two or more of these metals. *Magnalium* is an aluminium alloy containing 1–2 per cent. of magnesium, generally together with similar quantities of copper or nickel. *Duralumin* contains about 3·5 per cent. of copper, together with 0·5 per cent. or less of magnesium. Its properties may be modified in a remarkable manner by heat treatment.¹

Alloys of lead and tin.—Ordinary plumbers' solder consists of 67 per cent. of lead and 33 per cent. of tin; it is therefore composed of crystallites of lead, surrounded by the eutectic of the two metals. The structure is developed by polishing very lightly with chromic oxide. *Pewter* contains 8–15 per cent. of lead, the remainder being tin. It consists partly of a solid solution of lead in tin and partly of eutectic. *Hard lead*, used for acid-pumps, etc., consists of lead containing 10–15 per cent. of antimony, whilst the alloys containing up to 20 per cent. of antimony are also employed as *type-metal*. These alloys are composed of crystallites of antimony, embedded in a large quantity of the eutectic of the two metals. *Britannia metal* consists of tin, with 5–8 per cent. of antimony and occasionally a little lead; it consists essentially of a solid solution.

Bearing metals.—The bearing metals, or anti-friction alloys, may be considered together, in spite of the diversity of composition which they present, on account of the general similarity of their micrographic arrangement of constituents. The requisite properties are possessed by alloys consisting of a hard and a soft constituent, so distributed that the soft material provides the necessary plasticity, whilst the harder substance receives

¹ A. Wilm, *Metallurgie*, 1911, 8, 225.

the load and resists abrasion. Two methods of obtaining the required combination of properties are met with. According to the first, crystallites of one or more hard constituents are distributed through a soft ground-mass or matrix, whilst the second consists in preparing a sponge, the meshes of which are tough and moderately hard, filled up with a soft, plastic material. The first class includes the larger number of bearing metals.

The soft matrix is either lead or tin, or an alloy of these metals, containing a eutectic. The hard constituent is composed very frequently of the cubical crystals of tin and antimony, corresponding approximately with the formula SbSn (Plate VII., B). Binary alloys of lead and antimony are sometimes used, the crystallites of antimony in this case serving the same purpose. More frequently, all three metals are employed, in such proportions that the cubic constituent is present. The range of composition of such mixtures is very wide, and representatives of almost every member of the class are met with in practice. The addition of copper in small quantities provides an additional hard constituent, compounds of copper with tin or antimony separating in six-rayed stars of extreme hardness.¹ The rays have frequently a remarkable hollow structure, each ray resembling an elongated hexagonal box. The hard copper constituent becomes apparent in relief after polishing on a soft bed, without etching, whilst the cubes of tin and antimony do not make their appearance until after the surface has been etched. Lead has also been hardened by means of sodium, the hard constituent being the compound Na_2Pb_5 .

In the second class of bearing metals, the "plastic bronzes," the spongy mass is composed of copper hardened by means of tin, antimony, or nickel, the plastic filling material being chiefly lead. These alloys are obtained by the solidification of copper-lead emulsions, as although tin is added to increase the miscibility of the copper and lead, its quantity (about 6 per cent., against 25-30 per cent. of lead)

¹ These crystallites are stated by Charpy, *Étude des Alliages*, 225, to consist of Cu_3Sn and Cu_3Sb respectively, but such compounds are obviously incapable of existence in the presence of an excess of tin. The formulæ of the compounds in question remain uncertain; they must be rich in tin.

is insufficient to bring about the formation of a homogeneous liquid mixture. Under the conditions of casting, remarkably little separation of the two constituents of the emulsion takes place, and there is little segregation in the castings. Microscopically examined, the spongy structure of the plastic bronzes is clearly seen, the lead being enclosed in globules, without any trace of crystalline outline.

Brittle alloys.—A large number of alloys are produced commercially for the purpose of facilitating the addition of small quantities of elements to molten metals. The method of preparation frequently adopted is the reduction of the mixed oxides by means of aluminium. Silicon and phosphorus as such are never added to metals, rich alloys with iron, copper, or tin being usually employed. These rich alloys, composed principally of inter-metallic compounds, or of silicides, phosphides, etc., are commonly highly brittle, a property which is advantageous when it is desired to weigh definite small quantities for regulating the addition. Their microscopical examination is, however, beset with difficulties, owing to the fragility of the surfaces prepared by grinding. The process of preparing a flat section by means of emery leads to the breaking out of small particles, producing a rough, pitted surface, on which it is impossible to distinguish structure. Better results may often be obtained by employing a smooth carborundum block for grinding in place of emery paper.

The technical phosphor-copper, containing 10 per cent. P, consists of crystals of the phosphide, Cu_3P , surrounded by eutectic, and yields good micro-sections (see Plate IV.). Another quality, however, contains practically 15 per cent. P, and consists only of the phosphide, with traces of a second compound richer in phosphorus; it is almost impossible to polish. So, only the lower cupro-silicons lend themselves to microscopical examination. The metallography of these brittle alloys is still very imperfectly developed. The mechanical properties of alloys intended only for use as components of mixtures are, of course, unimportant, but a means of making a rapid metallographic examination is desirable, in order to determine the degree of purity of the alloy without recourse to a tedious chemical analysis.

APPENDIX

IN the following tables the binary and ternary systems, of which equilibrium diagrams have been published, are collected. The probable formulæ of inter-metallic compounds, when present, have been added, with some notes as to their position in the diagrams. Compounds, the evidence for which is unsatisfactory, are marked with a ? The systems in each class are arranged in alphabetical order of the symbols, each system appearing only once.

The references are not intended to form a complete bibliography. The reference placed against each system is to the most recent complete study of that system, or, when there is reason to reject an investigation as untrustworthy, to an earlier but more accurate investigation. In order to economize space, the following abbreviations have been used :—

- J.P.* = *J. Physical Chem.*
M. = *Metallurgie.*
R.M. = *Rev. de Métallurgie.*
Z.A. = *Zeitsch. anorg. Chem.*
Z.P. = *Zeitsch. physikal. Chem.*
A.A.L. = *Atti. R. Accad. Lincei.*
I.Z.M. = *Internat. Zeitsch. Metallographie.*

I

EUTECTIFEROUS SERIES

(Inter-metallic compounds being absent.)

The freezing-point curve of these systems has a **V** form. The components may crystallize in a pure state, or the crystals may retain a limited quantity of the other component in solid solution. The molten metals are miscible in all proportions.

System	Eutectic.		Solid solutions.	Reference.
	Atomic per cent.	Temp.		
Ag-Bi	4.6 Ag	262°	Ag dissolves 3 atom. % Bi.	G. J. Petrenko, <i>Z.A.</i> , 1906, 50 , 133.
Ag-Cu	60 Ag	778	8 and 97 atom. % Cu.	K. Friedrich and A. Leroux, <i>M.</i> , 1907, 4 , 293; W. von Lepkowski, <i>Z.A.</i> , 1908, 59 , 285.
Ag-Na	Near 100 Na	—	Very little.	E. Quercigh, <i>Z.A.</i> , 1910, 68 , 301; C. H. Mathewson, <i>I.Z.M.</i> , 1911, 1 , 51.

EUTECTIFEROUS SERIES—*continued.*

System.	Eutectic.		Solid solutions.	Reference.
	Atomic per cent.	Temp.		
Ag-Pb	4 Ag	305°	—	K. Friedrich, <i>M.</i> , 1906, 3 , 396.
Ag-Si	17 Si	800	—	G. Arrivaut, <i>Compt. rend.</i> , 1908, 147 , 859.
Ag-Tl	5 Ag	287	Ag dissolves 6 atom. % Tl.	G. J. Petrenko, <i>Z.A.</i> , 1906, 50 , 133.
Al-Si	9.5 Si	577	—	W. Fraenkel, <i>Z.A.</i> , 1908, 58 , 154.
Al-Sn	100 Sn	232	The extent to which solid solutions are formed is uncertain.	A. G. C. Gwyer, <i>Z.A.</i> , 1906, 49 , 311; E. S. Shepherd, <i>J.P.</i> , 1904, 8 , 233.
Au-Bi	18.9 Au	240	Au dissolves 4 atom. % Bi.	R. Vogel, <i>Z.A.</i> , 1906, 50 , 145.
Au-Co	72.9 Au	997°	—	W. Wahl, <i>Z.A.</i> , 1910, 66 , 60.
Au-Ni	48 Au	950	Limits uncertain.	M. Levin, <i>Z.A.</i> , 1905, 45 , 238.
Au-Tl	27 Au	132	—	M. Levin, <i>Z.A.</i> , 1905, 45 , 31.
Bi-Cd	55.5 Cd	146	—	A. Portevin, <i>R.M.</i> , 1907, 4 , 389; A. Stoffel, <i>Z.A.</i> , 1907, 53 , 137.
Bi-Cu	100 Bi	268	—	K. Jeriomin, <i>Z.A.</i> , 1907, 55 , 412.
Bi-Hg	Near 100 Hg	—	—	N. A. Pushin, <i>Z.A.</i> , 1903, 36 , 201.
Bi-Pb	56.5 Bi	125	Lead dissolves Bi to a considerable extent.	A. Kapp, <i>Ann. Physik.</i> , 1901, [iv.] 6 , 754.
Bi-Sn	43 Bi	137	—	A. Kapp, <i>Ann. Physik.</i> , 1901, [iv.] 6 , 754.
Cd-Pb	67 Cd	249	Lead dissolves about 4 atom. % Cd.	A. Kapp, <i>Ann. Physik.</i> , 1901, [iv.] 6 , 754.
Cd-Sn	67.6 Sn	177	Sn dissolves 10 atom. % Cd.	A. P. Schleicher, <i>I.Z.M.</i> , 1912, 2 , 76; A. Stoffel, <i>Z.A.</i> , 1907, 53 , 137.
Cd-Tl	70 Tl	203.5	—	N. S. Kurnakoff and N. A. Pushin, <i>Z.A.</i> , 1902, 30 , 86.
Cd-Zn	73 Cd	270	—	G. Hindrichs, <i>Z.A.</i> , 1907, 55 , 415.
Hg-Pb	Near 100 Hg	—	Lead dissolves about 30 atom. % Hg.	E. Jänecke, <i>Z.P.</i> , 1907, 60 , 399.
Hg-Sn	Near 100 Hg	—	—	W. J. v. Heteren, <i>Z.A.</i> , 1904, 42 , 129.
Hg-Zn	1 Zn	-42.5	Formed to an unknown extent.	N. A. Pushin, <i>Z.A.</i> , 1903, 36 , 201.
Pb-Sb	21 Sb	228	A compound is possibly formed in the solid state.	A. V. Saposchnikoff and I. Kanewsky, <i>J. Russ. Phys. Chem. Soc.</i> , 1907, 39 , 901; W. Gontermann, <i>Z.A.</i> , 1907, 55 , 419.

EUTECTIFEROUS SERIES—*continued.*

System.	Eutectic.		Solid solutions.	Reference.
	Atomic per cent.	Temp.		
Pb-Sn	75 Sn	180°	Lead dissolves tin.	W. Rosenhain and A. P. Tucker, <i>Phil. Trans.</i> , 1908, 209A, 89; P. N. Degens, <i>Z.A.</i> , 1909, 63, 207; D. Mazzotto, <i>I.Z.M.</i> , 1911, 1, 289.
Sb-Si	—	—	Very limited range.	R. S. Williams, <i>Z.A.</i> , 1907, 55, 1.
Si-Sn	100 Sn	232	—	S. Tamaru, <i>Z.A.</i> , 1909, 61, 40.
Sn-Tl	31 Tl	170.2	—	N. S. Kurnakoff and N. A. Pushin, <i>Z.A.</i> , 1902, 30, 86.
Sn-Zn	16 Zn	197	—	F. Rudberg, <i>Pogg. Ann.</i> , 1830, 18, 240.

II

ISOMORPHOUS SERIES

A. The freezing-point curve lies entirely between the freezing-points of the two components.

System.	Remarks.	Reference.
Ag-Au		W. C. Roberts-Austen and T. Kirke Rose, <i>Proc. Roy. Soc.</i> , 1903, 71, 161.
Ag-Pd		R. Ruer, <i>Z.A.</i> , 1906, 51, 315.
Au-Pd		R. Ruer, <i>Z.A.</i> , 1906, 51, 391.
Au-Pt	The platinum end of the curve is extrapolated, but is probably correct.	F. Doerinckel, <i>Z.A.</i> , 1907, 54, 333.
Bi-Sb	The curve possibly broken.	N. Parravano and E. Viviani, <i>A.A.L.</i> , 1910, [v] 19, i, 835.
Co-Fe	The α modifications (magnetic) are also isomorphous.	W. Guertler and G. Tammann, <i>Z.A.</i> , 1905, 45, 205.
Co-Ni	The α modifications (magnetic) are also completely isomorphous.	W. Guertler and G. Tammann, <i>Z.A.</i> , 1904, 42, 353.
Cu-Ni		W. Guertler and G. Tammann, <i>Z.A.</i> , 1907, 52, 25.
Cu-Pd		R. Ruer, <i>Z.A.</i> , 1906, 51, 223.
Cu-Pt		F. Doerinckel, <i>Z.A.</i> , 1907, 54, 333.
Fe-Mn		M. Levin and G. Tammann, <i>Z.A.</i> , 1905, 47, 136.
In-Pb		N. S. Kurnakoff and N. A. Pushin, <i>J. Russ. Phys. Chem. Soc.</i> , 1906, 38, 1146.

B. The freezing-point curve passes through a minimum.

System.	Remarks.	Reference.
Au-Cu	Formerly supposed to be a eutectiferous series. Min. at 883°.	N. S. Kurnakoff and S. F. Schemtschuschny, <i>Z.A.</i> , 1907, 54, 149.
Co-Cr	Min. at 1340°.	K. Lewkonja, <i>Z.A.</i> , 1908, 59, 293.
Cr-Ni		G. Voss, <i>Z.A.</i> , 1908, 57, 34.
Cu-Mn	Min. at 865°.	S. F. Schemtschuschny, G. Urazoff, and A. Rykowkoff, <i>Z.A.</i> , 1908, 57, 253.
Fe-V	Min. near 1400°.	R. Vogel and G. Tammann, <i>Z.A.</i> , 1908, 58, 73.
Mn-Ni	Min. at 1000°.	S. F. Schemtschuschny, G. Urazoff, and A. Rykowkoff, <i>Z.A.</i> , 1908, 57, 253.

C. The metals form two series of solid solutions, separated by a gap. The freezing-point curve presents a discontinuity.

System.	Break. Atomic per cent.	Limits of solid solutions.	Reference.
Au-Fe	45 Au	Very uncertain.	E. Isaac and G. Tammann, <i>Z.A.</i> , 1907, 53, 281.
Cd-Hg	65 Cd, 190°	75 and 77 Cd at 190°.	H. C. Bijl, <i>Z.P.</i> , 1902, 41, 641.
Co-Cu	4 Co, 1107°	65 and 80 Cd at 25°.	R. Sahmen, <i>Z.A.</i> , 1908, 57, 1.
Cu-Fe	2 Fe, 1100°	5 and 90 Co at 1107°.	R. Sahmen, <i>Z.A.</i> , 1908, 57, 1.
In-Tl	48 Tl, 180°	3 and 97 Fe at 1100°.	N. S. Kurnakoff and N. A. Pushin, <i>Z.A.</i> , 1907, 52, 430.
		Uncertain.	

III

The metals are only partially miscible in the liquid state.

System.	Remarks.	Reference.
Ag-Co	Immiscible at 1600°.	G. J. Petrenko, <i>Z.A.</i> , 1907, 53, 212.
Ag-Cr	Horizontal at 1460°.	G. Hindrichs, <i>Z.A.</i> , 1908, 59, 414.
Ag-Fe	Immiscible at 1600°.	G. J. Petrenko, <i>Z.A.</i> , 1907, 53, 212.
Ag-Mn	Horizontal at 1160°.	G. Hindrichs, <i>Z.A.</i> , 1908, 59, 414.

System.	Remarks.	Reference.
Ag-Ni	Horizontal at 1435°. Nickel retains 4% Ag in solid solution.	G. J. Petrenko, <i>Z.A.</i> , 1907, 53, 212.
Al-Bi	Very slight miscibility at 650°.	A. G. C. Gwyer, <i>Z.A.</i> , 1906, 49, 311.
Al-Cd	Immiscible at 654°.	A. G. C. Gwyer, <i>Z.A.</i> , 1908, 57, 113.
Al-K	" 657°.	D. P. Smith, <i>Z.A.</i> , 1907, 56, 109.
Al-Na	" 657°.	C. H. Mathewson, <i>Z.A.</i> , 1906, 48, 191.
Al-Pb	" 654°.	A. G. C. Gwyer, <i>Z.A.</i> , 1908, 57, 113.
Al-Tl	" 657°.	F. Doerinckel, <i>Z.A.</i> , 1906, 48, 185.
As-Bi	" 500°.	K. Friedrich and A. Leroux, <i>M.</i> , 1908, 5, 158.
Bi-Co		K. Lewkonja, <i>Z.A.</i> , 1908, 59, 293.
Bi-Cr		R. S. Williams, <i>Z.A.</i> , 1907, 55, 1.
Bi-Fe		E. Isaac and G. Tammann, <i>Z.A.</i> , 1907, 55, 58.
Bi-Si		R. S. Williams, <i>Z.A.</i> , 1907, 55, 1.
Bi-Zn		W. Spring and L. Romanoff, <i>Z.A.</i> , 1896, 13, 29.
Ca-Fe	Immiscible at 1550°.	C. Quasebart, <i>M.</i> , 1906, 3, 28; O. P. Watts, <i>J. Amer. Chem. Soc.</i> , 1906, 28, 1152.
Cd-Cr	Immiscible at 400°.	G. Hindrichs, <i>Z.A.</i> , 1908, 59, 414.
Cd-Fe		E. Isaac and G. Tammann, <i>Z.A.</i> , 1907, 55, 58.
Co-Pb		K. Lewkonja, <i>Z.A.</i> , 1908, 59, 293.
Co-Tl		K. Lewkonja, <i>Z.A.</i> , 1908, 59, 293.
Cr-Cu	Horizontal at 1464°.	G. Hindrichs, <i>Z.A.</i> , 1908, 59, 414.
Cr-Pb	" 1470°.	G. Hindrichs, <i>Z.A.</i> , 1908, 59, 414.
Cr-Sn	" 1420°.	G. Hindrichs, <i>Z.A.</i> , 1908, 59, 414.
Cr-Zn	Slightly miscible.	G. Hindrichs, <i>Z.A.</i> , 1908, 59, 414.
Cu-Pb	Horizontal at 957°.	C. T. Heycock and F. H. Neville, <i>Phil. Trans.</i> , 1897, 189A, 25.
Cu-Tl	Horizontal at 960°.	F. Doerinckel, <i>Z.A.</i> , 1906, 48, 185.
Fe-Pb		E. Isaac and G. Tammann, <i>Z.A.</i> , 1907, 55, 58.
Fe-Tl		E. Isaac and G. Tammann, <i>Z.A.</i> , 1907, 55, 58.
K-Mg	Immiscible at 700°.	D. P. Smith, <i>Z.A.</i> , 1907, 56, 109.
Mg-Na	Horizontal at 638°.	C. H. Mathewson, <i>Z.A.</i> , 1906, 48, 191.
Mn-Pb	" 1197°.	R. S. Williams, <i>Z.A.</i> , 1907, 55, 1.
Ni-Pb	" 1338°.	G. Voss, <i>Z.A.</i> , 1908, 57, 34.
Ni-Tl		G. Voss, <i>Z.A.</i> , 1908, 57, 34.
Pb-Si		S. Tamaru, <i>Z.A.</i> , 1909, 61, 40.
Pb-Zn		W. Spring and L. Romanoff, <i>Z.A.</i> , 1896, 13, 29.
Si-Tl		S. Tamaru, <i>Z.A.</i> , 1909, 61, 40.
Tl-Zn	Horizontal at 416°.	A von Vegesack, <i>Z.A.</i> , 1907, 52, 30.

IV

Series containing a single compound.

System.	Compound formula.	Properties.	Reference.
Ag-Pt	Ag ₂ Pt ?	Formed from Pt and liquid at 1185°. Forms solid solutions with Ag.	F. Doerinckel, <i>Z.A.</i> , 1907, 54 , 333.
Ag-Sb	Ag ₃ Sb	Formed from Ag and liquid at 560°. Solid solutions.	G. J. Petrenko, <i>Z.A.</i> , 1906, 50 , 133.
Ag-Sn	Ag ₃ Sn	Formed at 480° from α solid sol. and liquid. Transformation at 232°.	G. J. Petrenko, <i>Z.A.</i> , 1907, 53 , 200.
Al-Fe	Al ₃ Fe	F.P. curve very imperfect. Found also by analysis.	A. G. C. Gwyer, <i>Z.A.</i> , 1908, 57 , 113. O. Brunck, <i>Ber.</i> , 1901, 34 , 2733.
Al-Mg	Al ₃ Mg ₄	Max. F.P. at 462.7°. Solid sols. with Al.	G. Grube, <i>Z.A.</i> , 1905, 45 , 225.
Al-Sb	AlSb	Max. F.P. at ? Formed slowly in liquid.	G. Tammann, <i>Z.A.</i> , 1905, 48 , 53.
Al-Zn	Al ₂ Zn ₃ (?)	Stable only between 443° and 256°.	E. S. Shepherd, <i>J.P.</i> , 1905, 9 , 504; W. Rosenhain and S. L. Archbut, <i>Phil. Trans.</i> , 1911, 211A , 315.
Au-Na	Au ₂ Na	Max. F.P. at 989°. No solid solutions.	C. H. Mathewson, <i>I.Z.M.</i> , 1911, 1 , 81.
Au-Sb	AuSb ₂	Formed from Sb and liquid at 460°. No solid solutions.	R. Vogel, <i>Z.A.</i> , 1906, 50 , 145.
Au-Te	AuTe ₂	Max. F.P. at 464°.	G. Pellini and E. Quercigh, <i>A.A.L.</i> , 1910, [v] 19 , ii. 445.
Bi-Mg	Bi ₂ Mg ₃	Max. F.P. at 716°. No solid solutions.	G. Grube, <i>Z.A.</i> , 1906, 49 , 72.
Bi-Te	Bi ₂ Te ₃	Max. F.P. at 573°.	K. Mönkemeyer, <i>Z.A.</i> , 1905, 46 , 415.
Cd-Mg	CdMg	Forms solid sols. with both metals.	G. Grube, <i>Z.A.</i> , 1906, 49 , 72.
Cd-Te	CdTe	Max. F.P. at 1041°.	M. Kobayashi, <i>Z.A.</i> , 1910, 69 , 1.
Hg-Te	HgTe	Max. F.P. at 605°.	G. Pellini, <i>A.A.L.</i> , 1909, [v] 18 , ii. 211.
Hg-Tl	Hg ₂ Tl	Max. F.P. at 15°.	N. S. Kurnakoff and N. A. Pusbin, <i>Z.A.</i> , 1902, 30 , 86; A. Sucheni, <i>Zeitsch. Elektrochem.</i> , 1906, 12 , 726.
K-Na	KNa ₂	Formed from α and liquid at 6.88°.	N. S. Kurnakoff and N. A. Pushin, <i>Z.A.</i> , 1902, 30 , 109.
Mg-Pb	Mg ₂ Pb	Max. F.P. at 551.3°. No solid solutions.	G. Grube, <i>Z.A.</i> , 1905, 44 , 117; N. S. Kurnakoff and N. J. Stepanoff, <i>ibid.</i> , 1905, 46 , 177.

System.	Compound formula.	Properties.	Reference.
Mg-Sb	Mg ₃ Sb ₂	Max. F.P. at 950°. No solid solutions.	G. Grube, <i>Z.A.</i> , 1906, 49 , 72.
Mg-Si	Mg ₂ Si	Max. F.P. at 1102°. No solid solutions.	R. Vogel, <i>Z.A.</i> , 1909, 61 , 46; P. Lebeau and P. Bos-suet, <i>R.M.</i> , 1909, 6 , 273.
Mg-Sn	Mg ₂ Sn	Max. F.P. at 795°. No solid solutions.	N. S. Kurnakoff and N. J. Stepanoff, <i>Z.A.</i> , 1905, 46 , 177; G. Grube, <i>ibid.</i> , 1905, 46 , 76.
Mg-Zn	MgZn ₂	Max. F.P. at 595°. No solid solutions.	G. Grube, <i>Z.A.</i> , 1906, 49 , 72.
Pb-Te	PbTe	Max. F.P. at 917°.	H. Fay and G. Gillson, <i>Amer. Chem. J.</i> , 1902, 27 , 81.
Pb-Tl	PbTl ₂ ?	Max. F.P. at 380°. Solid sols. with Pb and Tl.	N. S. Kurnakoff and N. A. Pushin, <i>Z.A.</i> , 1907, 52 , 430; K. Lewkonja, <i>Z.A.</i> , <i>ibid.</i> , 452.
Sb-Te	Sb ₂ Te ₃	Max. F.P. at 561°.	H. Fay and H. E. Ashley, <i>Amer. Chem. J.</i> , 1902, 27 , 95.
Sb-Tl	SbTl ₃ ?	Formed from solid solution at 187°.	R. S. Williams, <i>Z.A.</i> , 1906, 50 , 127.
Sn-Te	SnTe	Max. F.P. at 780°.	H. Fay, <i>J. Amer. Chem. Soc.</i> , 1907, 29 , 1265; M. Kobayashi, <i>Z.A.</i> , 1910, 69 , 1.
Te-Zn	TeZn	Max. F.P. at 1238.5°.	M. Kobayashi, <i>I.Z.M.</i> , 1912, 2 , 65.

V

Complex series in which two or more inter-metallic compounds are formed, or in which the formation of immiscible liquid layers accompanies that of compounds.

System.	Compounds.	Remarks.	Reference.
Ag-Al	Ag ₃ Al Ag ₂ Al	Formed at 770° from solid solution and liquid. Formed at 719° from Ag ₂ Al and liquid. Both form solid sols. Ag ₃ Al forms α and β modifications. AgAl (by E.M.F.) does not exist.	G. J. Petrenko, <i>Z.A.</i> 1905, 46 , 49.

V—continued.

System.	Compounds.	Remarks.	Reference.
Ag-Cd	AgCd ? Ag ₂ Cd ₃ AgCd ₃ ?	Formed in solid at 200°. Formed from liquid at 633°. Formed from liquid at 568°.	G. Bruni and E. Quercigh, <i>Z.A.</i> , 1910, 68 , 198; G. J. Petrenko and A. S. Fedoroff, <i>Z.A.</i> , 1911, 70 , 157; 71 , 215.
Ag-Mg	AgMg AgMg ₃	Max. F.P. at 820°. Formed at 492° from solid solution and liquid. Ag forms solid sols. with 28% Mg, and AgMg with 12 Ag and 16 Mg.	S. F. Schemtschn-schny, <i>Z.A.</i> , 1906, 49 , 400.
Ag-Te	AgTe Ag ₂ Te	Formed from liquid at 444°. Max. F.P. at 959°.	G. Pellini and E. Quercigh, <i>A.A.L.</i> , 1910, [v] 19 , ii, 415.
Ag-Zn	AgZn ? Ag ₂ Zn ₃ Ag ₂ Zn ₅	Formed at 665° from β and liquid. Formed at 636° from Ag ₂ Zn ₃ and liquid.	H. C. H. Carpenter and W. Whiteley, <i>I.Z.M.</i> , 1912, 3 , 145.
Al-Au	Al ₂ Au AlAu AlAu ₂ Al ₂ Au ₅ AlAu ₄ ?	Max. F.P. at 1060°. Formed at 625° from Al ₂ Au and liquid. Max. F.P. at 624°. Formed at 575° from AlAu ₂ and liquid. Formed at 545° from Au and liquid.	C. T. Heycock and F. H. Neville, <i>Phil. Trans.</i> , 1900, 194A , 201.
Al-Ca	Al ₃ Ca	Crystallizes at 692°. Horizontal at 692° from 11 to 34 atom. % Ca.	L. Doński, <i>Z.A.</i> , 1908, 57 , 185.
Al-Co	Al ₁₃ Co ₃ ? Al ₅ Co ₂ AlCo	Formed at 940° from Al ₅ Co ₂ and liquid. Formed at 1165° from AlCo and liquid. Max. F.P. at 1628°.	A. G. C. Gwyer, <i>Z.A.</i> , 1908, 57 , 113.
Al-Cr	AlCr ₃ ?	Very high m.p. Found by extrapolation. Two liquid layers over part of range.	G. Hindrichs, <i>Z.A.</i> , 1908, 59 , 414.

System.	Compounds.	Remarks.	Reference.
Al-Cu	Al ₂ Cu	Formed at 588° from AlCu and liquid.	H. C. H. Carpenter and C. A. Edwards, <i>Proc. Inst. Mech. Eng.</i> , 1907, 57; B. E. Curry, <i>J.P.</i> , 1907, 11, 425.
	AlCu	Formed at 625° from solid solution and liquid.	
	AlCu ₃ AlCu ₄ ?	Max. F.P. at 1050°.	
		A complex system, in which the solid sols. vary greatly in composition with the temperature.	
Al-Mn	Al ₃ Mn? AlMn ₃	Max. F.P. at 1279°.	G. Hindrichs, <i>Z.A.</i> , 1908, 59, 414.
		Two liquid layers also formed.	
Al-Ni	Al ₃ Ni	Formed at 835° from Al ₂ Ni and liquid.	A. G. C. Gwyer, <i>Z.A.</i> , 1908, 57, 113.
	Al ₂ Ni	Formed at 1130° from AlNi and liquid.	
	AlNi ●	Max. F.P. at 1629°; forms solid solutions with Ni.	
As-Cu	As ₂ Cu ₅	Formed at 711° from AsCu ₃ and liquid.	K. Friedrich, <i>M.</i> , 1908, 5, 529.
	AsCu ₃	Max. F.P. at 830°.	
Au-Cd	Au ₄ Cd ₃	Formed at 625° from Au and liquid.	R. Vogel, <i>Z.A.</i> , 1906, 48, 333.
	AuCd ₃	Formed at 495° from Au ₄ Cd ₃ and liquid.	
		Solid solutions formed.	
Au-Mg	AuMg	Mat. F.P. at 1150°.	R. Vogel, <i>Z.A.</i> , 1909, 63, 169; G. Urazoff, <i>Z.A.</i> , 1909, 64, 375; G. Urazoff and R. Vogel, <i>Z.A.</i> , 1910, 67, 442.
	AuMg ₂	„ „ 788°.	
	Au ₂ Mg ₅	Formed at 796° from AuMg ₃ and liquid.	
	AuMg ₃	Max. F.P. at 818°.	
		Solid solutions formed.	
Au-Pb	Au ₂ Pb	Formed at 418° from Au and liquid.	R. Vogel, <i>Z.A.</i> , 1905, 45, 11.
	AuPb ₂	Formed at 254° from Au ₂ Pb and liquid.	
		AuPb ₂ has a transformation point at 211°. No solid sols.	
Au-Sn	AuSn	Max. F.P. at 418°.	R. Vogel, <i>Z.A.</i> , 1905, 46, 60.
	AuSn ₂	Formed at 308° from AuSn and liquid.	
	AuSn ₄	Formed at 252° from AuSn ₂ and liquid.	
Au-Zn	AuZn	Max. F.P. at 744°.	R. Vogel, <i>Z.A.</i> , 1906, 48, 319.
	Au ₃ Zn ₅	Formed at 651° from solid solution and liquid.	
	AuZn ₈ ?	Formed at 490° from solid solution and liquid.	

V—continued.

System.	Compounds.	Remarks.	Reference.
Bi-K	Bi ₂ K	Max. F.P. at 540°.	D. P. Smith, <i>Z.A.</i> , 1907, 56, 109.
	Bi ₇ K ₉ ?	Formed at 373° from Bi ₂ K ₃ and liquid.	
	Bi ₂ K ₃	Formed at 420° from BiK ₃ and liquid.	
Bi-Na	BiK ₃	Max. F.P. at 671°. No solid solutions.	C. H. Mathewson, <i>Z.A.</i> , 1906, 50, 171.
	BiNa	Formed at 445° from BiNa ₃ and liquid.	
	BiNa ₃	Max. F.P. at 775°. No solid solutions.	
Bi-Ni	Bi ₃ Ni	Formed at 469° from BiNi and liquid.	G. Voss, <i>Z.A.</i> , 1908, 57, 34.
	BiNi	Formed at 655° from Ni and liquid.	
Bi-Tl	Bi ₅ Tl ₃ BiTl ₂	Max. F.P. at 227°. The curve is unsatisfactory, and there is probably a third compound.	M. Chikashigé, <i>Z.A.</i> , 1906, 51, 328.
Ca-Cd	Ca ₃ Cd ₂	Formed at 510° from CaCd and liquid.	L. Doński, <i>Z.A.</i> , 1908, 57, 185.
	CaCd	Crystallizes at 685°.	
	CaCd ₃	Formed at 615° from CaCd and liquid.	
Ca-Zn	CaZn ?	Horizontal at 685° from 28 to 83 atom. % Ca.	L. Doński, <i>Z.A.</i> , 1908, 57, 185.
	Ca ₂ Zn ₃	Formed at 431° from Ca ₂ Zn ₃ and liquid.	
	CaZn ₄	Max. F.P. at 688°.	
Cd-Cu	CaZn ₁₀	Formed at 680° from CaZn ₁₀ and liquid.	R. Sahmen, <i>Z.A.</i> , 1906, 49, 301.
	Cd ₃ Cu ₂	Max. F.P. at 717°.	
	CdCu ₂	Max. F.P. at 565°. Forms solid solutions.	
Cd-K	Cd ₇ K ?	Formed at 552° from Cu and liquid.	D. P. Smith, <i>Z.A.</i> , 1907, 56, 109.
	Cd ₁₁ K ?	Very doubtful. Max. F.P. at 473°.	
Cd-Na	Cd ₆ Na	Horizontal at 468°.	C. H. Mathewson, <i>Z.A.</i> , 1906, 50, 171 ; N. S. Kurnakoff and A. N. Kusnet- zoff, <i>ibid.</i> , 1907, 52, 173.
	Cd ₂ Na	Max. F.P. at 363°.	
		" " 385°. Horizontal at 330° from 58 to 70 atomic % Na.	
Cd-Sb	Cd ₃ Sb ₂	Formed at 409° from CdSb and liquid.	W. Treitschke, <i>Z.A.</i> , 1906, 50, 217 ; N. S. Kurnakoff and N.A. Konstantinoff, <i>ibid.</i> , 1908, 58, 1.
	CdSb	Max. F.P. at 455°. The latter is often suppressed by undercooling.	

System.	Compounds.	Remarks.	Reference.
Co-Sb	CoSb CoSb ₂	Max. F.P. at 1191°. Formed at 898° from CoSb and liquid.	K. Lewkonja, <i>Z.A.</i> , 1908, 59, 293.
Co-Si	Co ₂ Si Co ₃ Si ₂ ? CoSi CoSi ₂	Max. F.P. at 1327°. Formed slowly at 1180-1215°. Max. F.P. at 1395°. Formed at 1277° from CoSi and liquid.	K. Lewkonja, <i>Z.A.</i> , 1908, 59, 293.
Co-Sn	CoSi ₃ Co ₂ Sn CoSn	Max. F.P. at 1310°. Max. F.P. at 1171°. Formed at 927° from Co and liquid. CoSn has a transition-point at 515°; both α and β forms are non-magnetic.	S. F. Schemtschuschny and S. W. Belynsky, <i>Z.A.</i> , 1908, 59, 364; K. Lewkonja, <i>ibid.</i> , 293.
Cr-Sb	CrSb CrSb ₂	Max. F.P. at 1112°. Forms solid solutions with Cr. Formed at 675° from CrSb and liquid.	R. S. Williams, <i>Z.A.</i> , 1907, 55, 1.
Cs-Hg	Cs ₂ Hg ? CsHg ? CsHg ₂ CsHg ₄ CsHg ₆ CsHg ₁₀ ?	Max. F.P. at 208°. " " 163.5°. " " 152.7°. Formed from CsHg ₆ and liquid at 13°.	N. S. Kurnakoff and G. U. Schukowsky, <i>Z.A.</i> , 1907, 52, 416.
Cu-Mg	Cu ₂ Mg CuMg ₂	Max. F.P. at 800°. " " 575°. No solid solutions.	R. Sahmen, <i>Z.A.</i> , 1908, 57, 1; G. G. Urazoff, <i>Ź. Russ. Phys. Chem. Soc.</i> , 1907, 39, 1566.
Cu-Sb	Cu ₃ Sb Cu ₂ Sb	Max. F.P. at 680°. Formed from Cu ₃ Sb and liquid at 580°. Complex transformations in solid state.	A. Baikoff, <i>Ź. Russ. Phys. Chem. Soc.</i> , 1904, 36, 111.
Cu-Si	Cu ₃ Si	Max. F.P. at 862°. The remainder of the system is doubtful.	E. Rudolphi, <i>Z.A.</i> , 1907, 53, 216; P. Lebeau, <i>Compt. rend.</i> , 1906, 142, 154.
Cu-Sn	Cu ₄ Sn ? Cu ₃ Sn CuSn ?	The only compound established with certainty.	C. T. Heycock and F. H. Neville, <i>Phil. Trans.</i> , 1903, 202A, 1; F. Giolitti and G. Tavanti, <i>Gazzetta</i> , 1908, 38, ii, 209.
Cu-Te	Cu ₂ Te	Formed at 855° from Cu and liquid. Two polymorphic changes at 384° and 355°.	M. Chikashigé, <i>Z.A.</i> , 1907, 54, 50.

V—continued.

System.	Compounds.	Remarks.	Reference.
	Cu_4Te_3	Formed at 620° from $\gamma\text{Cu}_2\text{Te}$ and liquid. Polymorphic change at 620° . Two liquid layers at 1030° from 68 to 90 atomic % Cu.	
Cu-Zn	Cu_2Zn ?	Formed at 905° from α solid and liquid.	E.S. Shepherd, <i>J.P.</i> , 1904, 8, 421; V.E. Tafel, <i>M.</i> , 1908, 5, 343.
	Cu_2Zn_3	Formed at 830° from β solid and liquid. Other compounds may exist, but their formulæ are uncertain.	
Fe-Sb	Fe_3Sb_2	Max. F.P. at 1016° . Solid solutions with Fe and Sb.	N. S. Kurnakoff and N. Konstantinoff, <i>Z.A.</i> , 1908, 58, 1.
	FeSb_2	Formed at 730° from Fe_3Sb_2 and liquid.	
Fe-Si	Fe_2Si	Formed at 1250° from solid solution and liquid.	W. Guertler and G. Tammann, <i>Z.A.</i> , 1905, 47, 163.
Fe-Sn	FeSi ?	Max. F.P. at 1443° . Horizontal at 1140° . Iron retains some Sn in solid solution. The evidence for a compound depends on thermal arrests at 893° , 780° , and 496° . The formula is quite undetermined.	E. Isaac and G. Tammann, <i>Z.A.</i> , 1907, 53, 281.
Hg-K	HgK	Formed from Hg_2K and liquid at 178° .	E. Jänecke, <i>Z.P.</i> , 1907, 53, 245.
	Hg_2K	Max. F.P. at 270° .	
	Hg_3K ?	Formed from Hg_2K and liquid at 204° .	
	Hg_5K_2 ?	Formed from Hg_3K and liquid at 173° .	
	Hg_9K	Formed from Hg_5K_2 and liquid at 70° .	
Hg-Na	Hg_1Na	Formed from Hg_2Na and liquid at 159° .	A. Schüller, <i>Z.A.</i> , 1904, 40, 385; E. Vanstone, <i>Trans. Faraday Soc.</i> , 1911, 7, 42.
	Hg_2Na	Max. F.P. at 360° .	
	$\text{Hg}_{13}\text{Na}_{12}$ (or Hg_3Na_7) ?	Formed from Hg_2Na and liquid at 227° .	
	HgNa	Formed from $\text{Hg}_{13}\text{Na}_{12}$ and liquid at 219° .	
	Hg_2Na_3	Formed from HgNa and liquid at 123° .	
	Hg_2Na_5 ?	Formed from Hg_2Na_3 and liquid at 62° .	
	HgNa_3	Formed from Hg_2Na_5 and liquid at 34° .	

System.	Compounds.	Remarks.	Reference.
Hg-Rb	Hg ₈ Rb	Max. F.P. at 136.5°. Possibly a second compound.	N. S. Kurnakoff and G. U. Schukowsky, <i>Z. Russ. Phys. Chem. Soc.</i> , 1906, 38 , 1216.
K-Pb		Horizontal at 568° from 35 to 75 atomic % K.	D. P. Smith, <i>Z.A.</i> , 1907, 56 , 109.
	K ₂ Pb?	Formed from unknown solid at 375°.	
	KPb ₂ ?	Formed from unknown solid at 337°.	
	KPb ₄ ?	Formed from KPb ₂ and liquid at 295°. Very uncertain.	
K-Sn	K ₂ Sn?	Formed from KSn and liquid at 535°.	D. P. Smith, <i>Z.A.</i> , 1907, 56 , 109.
	KSn?	Formed from an unknown compound at 670°.	
	KSn ₂	Formed from an unknown compound at 600°.	
	KSn ₄	Formed from KSn ₂ and liquid at 413°. These formulæ are very doubtful.	
K-Tl	K ₂ Tl?	Formed from KTL and liquid at 240°.	N. S. Kurnakoff and N. A. Pushin, <i>Z.A.</i> , 1902, 30 , 86.
	KTl	Max. F.P. at 335°.	
K-Zn	KZn ₁₁ ?	Very doubtful. Horizontal at 585°. Compound supposed to undergo transformation near 500°.	D. P. Smith, <i>Z.A.</i> , 1907, 56 , 109.
Li-Sn	Li ₄ Sn	Max. F.P. at 680°.	G. Masing and G. Tammann, <i>Z.A.</i> , 1910, 67 , 183.
	Li ₃ Sn ₂	" " 465°.	
	Li ₂ Sn ₅	Formed from liquid at 320°.	
Mg-Ni	Mg ₂ Ni	Formed at 768° from MgNi ₂ and liquid.	G. Voss, <i>Z.A.</i> , 1908, 57 , 34.
	MgNi ₂	Very flat max. F.P. at 1145°.	
Mg-Tl	Mg ₈ Tl ₃ ?	Max. F.P. at 415°.	G. Grube, <i>Z.A.</i> 1905, 46 , 76.
	Mg ₂ Tl	Formed at 393° from Mg ₈ Tl ₃ and liquid.	
	Mg ₃ Tl ₂	Formed at 355° from Mg ₂ Tl and liquid.	
Mn-Sb	Mn ₂ Sb	Max. F.P. at 920°. Solid solutions with Mn and Sb.	R. S. Williams, <i>Z.A.</i> , 1907, 55 , 1.
	Mn ₃ Sb ₂	Formed at 850° from solid solution (Mn ₂ Sb) and liquid. Solid solutions with Sb.	
Mn-Si	Mn ₂ Si	Max. F.P. at 1316°.	F. Doerinckel, <i>Z.A.</i> , 1906, 50 , 117.
	MnSi	" " 1280°.	
Mn-Sn	Mn ₄ Sn	Formed at 980°.	R. S. Williams, <i>Z.A.</i> , 1907, 55 , 1.
	Mn ₂ Sn	" 898°.	

V—continued.

System.	Compounds.	Remarks.	Reference.
Na-Pb	MnSn	Formed at 541°.	C. H. Mathewson, <i>Z.A.</i> , 1906, 50 , 171.
	Na ₄ Pb	Max. F.P. at 386°.	
	Na ₃ Pb	„ „ 405°.	
	NaPb	„ „ 367°.	
Na-Sb	Na ₂ Pb ₃	„ „ 319°.	C. H. Mathewson, <i>Z.A.</i> , 1906, 50 , 171.
	Na ₂ Sb	Max. F.P. at 856°.	
	NaSb	„ „ 465°.	
Na-Sn	Na ₄ Sn	Formed from Na ₂ Sn and liquid at 405°.	C. H. Mathewson, <i>Z.A.</i> , 1906, 50 , 171.
	Na ₂ Sn	Max. F.P. at 477°.	
	Na ₄ Sn ₃	Formed from NaSn and liquid at 473°.	
	NaSn	Max. F.P. at 576°.	
Na-Te	NaSn ₂	Formed from NaSn and liquid at 405°.	G. Pellini and E. Quercigh, <i>A.A.L.</i> , 1910, [v] 19 , ii, 350.
	Na ₂ Te	Max. F.P.	
	Na ₃ Te ₂		
Na-Tl	Na ₃ Te ₇		N. S. Kurnakoff and N. A. Pushin, <i>Z.A.</i> , 1902, 30 , 86.
	Na ₃ Tl ₂ ?	Formed from Na ₂ Tl and liquid at 78°.	
Na-Zn	Na ₂ Tl?	Formed from NaTl and liquid at 159°.	C. H. Mathewson, <i>Z.A.</i> , 1906, 48 , 191.
	NaTl	Max. F.P. at 306°.	
	NaZn ₁₁ ?	Doubtful. Horizontal at 557°.	
Ni-Sb	Ni ₃ Sb	Formed at 670° from solid sol.	K. Lossev, <i>Z.A.</i> , 1906, 49 , 58; <i>J.</i> <i>Russ. Phys. Chem.</i> <i>Soc.</i> , 1911, 43 , 375.
	Ni ₅ Sb ₂	Max. F.P. at 1170°. Solid solutions with Ni.	
	NiSb	Max. F.P. at 1107°. Solid solutions with Ni.	
	Ni ₂ Sb ₃	Formed at 618° from NiSb and liquid.	
Ni-Si	Ni ₃ Si?	Formed near 1125° from solid solution.	W. Guertler and G. Tammann, <i>Z.A.</i> , 1906, 49 , 93.
	Ni ₂ Si	Max. F.P. at 1310°.	
	Ni ₃ Si ₂ ?	Formed near 830° from solid solution.	
	NiSi	Max. F.P. at 1000°.	
Ni-Sn	Ni ₂ Si ₃	Formed at 985° from Si and liquid. The diagram is complex and imperfectly known.	G. Voss, <i>Z.A.</i> , 1908, 57 , 34; L. Guillet, <i>Bull. Soc. chim.</i> , 1907, [iv.] 1 , 775.
	Ni ₄ Sn	Formed at 855° from solid.	
	Ni ₃ Sn	„ „ 1162° from Ni ₃ Sn ₂ and liquid.	
Ni-Zn	Ni ₃ Sn ₂	Formed at 1263°.	V. E. Tafel, <i>M.</i> , 1908, 5 , 413; G. Voss, <i>Z.A.</i> , 1908, 57 , 34.
	NiZn ₃	Max. F.P. at 876°.	
	NiZn	Formed from liquid at 1035°.	

System.	Compounds.	Remarks.	Reference.
Pb-Pd	Pb ₂ Pd	Max. F.P. at 457°.	R. Ruer, <i>Z.A.</i> , 1907, 52, 345; N. A. Pushin and N. Paschsky, <i>J. Russ. Phys. Chem. Soc.</i> , 1908, 40, 826.
	PbPd	Formed at 595° from solid solution and liquid.	
Pb-Pt	PbPd ₂	Formed at 830° from PbPd ₃ and liquid.	F. Doerinckel, <i>Z.A.</i> , 1907, 54, 333; N. A. Pushin and P. N. Laschtschenko, <i>ibid.</i> , 1909, 62, 34.
	PbPd ₃	Max. F.P. at 1220°.	
	Pb ₂ Pt	Formed at 356° from PbPt and liquid.	
	PbPt	Formed at 787° from an unknown compound and liquid.	W. Sander, <i>Z.A.</i> , 1912, 75, 97.
Pd-Sb	Pd ₂ Sb	Max. F.P. at 1220°.	K. Friedrich and A. Leroux, <i>M.</i> , 1909, 6, 1.
	Pd ₃ Sb ₃	Formed at 839°.	
Pt-Sb	PdSb	Formed at 805°.	N. Podkopaëff, <i>J. Russ. Phys. Chem. Soc.</i> , 1908, 40, 249; F. Doerinckel, <i>Z.A.</i> , 1907, 54, 333.
	PdSb ₂	Max. F.P. at 680°.	
	Pt ₂ Sb ₂	Formed in solid at 644°.	
	PtSb	Formed from PtSb ₂ and liquid at 1045°.	
Pt-Sn	PtSb ₂	Max. F.P. at 1226°.	J. E. Stead, <i>J. Soc. Chem. Ind.</i> , 1897, 16, 200; W. Reinders, <i>Z.A.</i> , 1900, 25, 113; R. S. Williams, <i>ibid.</i> , 1907, 55, 1.
	PtSn ₃	Formed at 540° from αPt ₂ Sn ₃ and liquid.	
	Pt ₂ Sn ₃	Formed at 850° from PtSn and liquid. Polymorphic change at 740°.	
	PtSn	Max. F.P. at about 1300°.	S. F. Schemtschuschny, <i>Z.A.</i> , 1906, 49, 384; K. Mönkemeyer, <i>ibid.</i> , 1905, 43, 182.
	Pt ₃ Sn	Formed at about 1400° from Pt and liquid.	
Sb-Sn	SbSn	Four series of solid solutions, with breaks at 7.5 and 50 atomic % Sb.	
	Sb ₂ Sn ₂		
Sb-Zn	SbZn	Formed at 535° from Sb ₂ Zn ₃ and liquid.	
	Sb ₂ Zn ₃	Max. F.P. at 566°. Polymorphic change at about 355°. Formation of SbZn easily suppressed by undercooling.	

VI

Systems which have not been completely investigated. In some instances the freezing-point determinations have been limited to a certain range of composition by the volatility of one of the components under atmospheric pressure.

System.	Compounds.	Remarks.	Reference.
Ag-As		A compound Ag_3As is possible.	K. Friedrich and A. Leroux, <i>M.</i> , 1906, 3, 192.
Ag-Hg	Ag_2Hg_4	Solid solutions are formed.	A. Ogg, <i>Z.P.</i> , 1898, 27, 285.
As-Co	AsCo	Max. F.P. near 1180° .	K. Friedrich, <i>M.</i> , 1908, 5, 150.
	As_2Co_3	Formed at 1010° from AsCo and liquid.	
	AsCo_2	Formed at 960° from As_2Co_3 and liquid.	
	As_2Co_3	Formed at 900° from AsCo_2 and liquid.	
		A complicated system, with many transformations in the solid state.	
As-Fe	AsFe	Max. F.P. at 1030° .	K. Friedrich, <i>M.</i> , 1907, 4, 129.
	As_2Fe_3	Formed at 800° from solid.	
	AsFe_2	Max. F.P. at 919° .	
As-Mn	AsMn_2	Max. F.P. at 1022° .	P. Schoen, <i>M.</i> , 1911, 8, 739.
	AsMn	" " 955° .	
	$\text{As}_2\text{Mn}_3?$	Formed from solid.	
As-Ni	AsNi	Max. F.P. at 968° .	K. Friedrich and F. Bennigson, 1907, 4, 200.
	$\text{As}_2\text{Ni}_3?$	Formed near 800° .	
	As_2Ni_5	Max. F.P. at 998° .	
As-Pb	?	No compound observed with certainty.	K. Friedrich, <i>M.</i> , 1906, 3, 41.
As-Pt	As_3Pt_2	Max. F.P. near 1450° ; found by slight extrapolation.	K. Friedrich and A. Leroux, <i>M.</i> , 1908, 5, 148.
As-Sb		Solid solutions from 0 to 50 atom % As.	N. Parravano and P. de Cesaris, <i>I.Z.M.</i> , 1912, 2, 70.
As-Sn	As_2Sn_3	Formed at 578° .	N. Parravano and P. de Cesaris, <i>I.Z.M.</i> , 1912, 2, 1.
	AsSn	Max. F.P. at 585° .	
As-Zn	$\text{As}_2\text{Zn}_3?$	One compound of uncertain composition.	K. Friedrich and A. Leroux, <i>M.</i> , 1906, 3, 477.
Bi-Ca	?	One compound of unknown composition, formed at 500° .	L. Doński, <i>Z.A.</i> , 1908, 57, 185.

System.	Compounds.	Remarks.	Reference.
Ca-Cu	?	Only a very small range investigated.	L. Doński, <i>Z.A.</i> , 19 8, 57, 185.
Ca-Pb	CaPb ₃	Max. F.P. at 650°.	L. Doński, <i>Z.A.</i> , 1908, 57, 185.
Ca-Sn	CaSn ₃	Max. F.P. at 624°.	L. Doński, <i>Z.A.</i> , 1908, 57, 185.
Ca-Sb		No compound found within the range investigated.	L. Doński, <i>Z.A.</i> , 1908, 57, 185.
Ca-Si	CaSi ₂	Formed at about 990°. Course of F.P. curve doubtful.	S. Tamaru, <i>Z.A.</i> , 1909, 62, 81.
Ca-Tl	CaTl ₃ CaTl?	Formed at 524°.	L. Doński, <i>Z.A.</i> , 1908, 57, 185.
Cd-Ni	Cd ₄ Ni	Formed at 501° from an unknown compound and liquid.	G. Voss, <i>Z.A.</i> , 1908, 57, 34.
Co-P	Co ₂ P	Max. F.P. at 1386°.	S. F. Schemtschuschny and J. Schepeleff, <i>Z.A.</i> , 1909, 64, 245.
Co-Zn	CoZn ₄ ?	Doubtful.	K. Lewkonja, <i>Z.A.</i> , 1908, 59, 293.
Cr-Fe	?	F. P. curve very irregular, and formula of compound not determined.	W. Treitschke and G. Tammann, <i>Z.A.</i> , 1907, 55, 402.
Cu-P	Cu ₃ P	Max. F.P. near 1022°. A higher phosphide, perhaps, also formed.	E. Heyn and O. Bauer, <i>Z.A.</i> , 1907, 52, 129; A. K. Huntington and C. H. Desch, <i>Trans. Faraday Soc.</i> , 1908, 4, 51.
Fe-Mo	?	F.P. curve irregular. Formula of compound not determined.	Lautsch and G. Tammann, <i>Z.A.</i> , 1907, 55, 386.
Fe-Ni	FeNi ₂ ?	Formula doubtful. F.P. curve continuous.	W. Guertler and G. Tammann, <i>Z.A.</i> , 1905, 45, 205; R. Ruer and E. Schütz, <i>M.</i> , 1910, 7, 415.
Fe-P	Fe ₃ P Fe ₂ P	Formed at 1130°. Max. F.P. at 1350°.	N. A. Konstantinoff, <i>Z.A.</i> , 1909, 66, 209.
Fe-Pt		Isomorphous, solid solutions breaking up at a lower temperature.	E. Isaac and G. Tammann, <i>Z.A.</i> , 1907, 55, 63.
Fe-W	?	F.P. curve irregular. Formula of compound not determined.	H. Harkort, <i>M.</i> , 1907, 4, 617, 639, 673.
Fe-Zn	FeZn ₃ ? FeZn ₇ ?	Formed at 777°. " 662° from FeZn ₃ and liquid.	A. von Vegesack, <i>Z.A.</i> , 1907, 52, 30.

VI—continued.

System.	Compounds.	Remarks.	Reference.
Mn-P	Mn ₅ P ₂ MnP	Max. F.P. at 1390°. The F.P. curve rises from a eutectic point, indicating a probable max. near 1180°; but the system has only been investigated as far as 47 atomic % P.	S. F. Schemtschuschny and N. N. Efremoff, <i>J. Russ. Phys. Chem. Soc.</i> , 1907, 39 , 777.
Ni-P	Ni ₃ P Ni ₅ P ₂ Ni ₂ P	Formed at 965° from βNi ₅ P ₂ and liquid. Max. F.P. at 1185° Polymorphic change at 1025°. Max. F.P. at 1112°. At least one more compound must exist.	N. A. Konstantinoff, <i>Z.A.</i> , 1908, 60 , 405.

VII

TERNARY SYSTEMS

The freezing-point or liquidus surfaces of most of the following systems have been determined accurately. In most cases the solidus has also been determined, whilst the study of the exact nature of the transformations in the solid state is less complete.

System.	Remarks.	Reference.
Ag-Au-Cu	Solid solutions with a gap. No compound or ternary eutectic.	E. Jänecke, <i>M.</i> , 1911, 8 , 597.
Ag-Cu-Pb	No ternary compound. One ternary eutectic, and a region of limited miscibility.	K. Friedrich and A. Leroux, <i>M.</i> , 1907, 4 , 293.
Ag-Pb-Sn	No ternary eutectic.	N. Parravano, <i>I.Z.M.</i> , 1911, 1 , 89.
Ag-Pb-Zn	No ternary eutectic. The lead has little effect on the AgZn system.	R. Kremann and F. Hofmeier, <i>Monatsh.</i> , 1911, 32 , 563.
Al-Cu-Sn	No ternary compound. Complex changes in solid solution.	J. H. Andrew and C. A. Edwards, <i>Proc. Roy. Soc.</i> , 1909, 82A , 568; <i>J. Inst. Metals</i> , 1910, 2 , 209.
Al-Cu-Zn	Partially investigated.	H. C. H. Carpenter and C. A. Edwards, <i>I.Z.M.</i> , 1912, 2 , 209.
Bi-Cd-Pb	Ternary eutectic at 91.5°.	W. E. Barlow, <i>J. Amer. Chem. Soc.</i> , 1910, 32 , 1390.

System.	Remarks.	Reference.
Bi-Cd-Sn	No ternary compound. One ternary eutectic.	A. Stoffel, <i>Z.A.</i> , 1907, 53 , 139.
Bi-Cu-Sb	No ternary compound. Two liquid phases.	N. Parravano and E. Viviani, <i>A.A.L.</i> , 1910, [v] 19 , ii. 1068.
Bi-Pb-Sn	No ternary compound. One ternary eutectic.	G. Charpy, <i>Étude des Alliages</i> , 201; E. S. Shepherd, <i>J.P.</i> , 1902, 6 , 519.
Cd-Cu-Sb	Stable and metastable systems.	A. P. Schleicher, <i>I.Z.M.</i> , 1912, 3 , 102.
Cd-Hg-Na	? CdHgNa; max. F.P. at 325°.	E. Jänecke, <i>Z.P.</i> , 1906, 57 , 507.
Cd-Hg-Pb	No ternary compound.	E. Jänecke, <i>Z.P.</i> , 1907, 60 , 399.
Cd-Mg-Zn	Ternary eutectic at 250°.	G. Bruni, G. Sandonnini, and E. Quercigh, <i>Z.A.</i> , 1910, 68 , 73; G. Bruni and G. Sandonnini, <i>Z.A.</i> , 1912, 78 , 273.
Cd-Pb-Sn	No ternary compound. One ternary eutectic.	A. Stoffel, <i>Z.A.</i> , 1907, 53 , 129.
Cu-Fe-Mn	Solid solutions with gap.	N. Parravano, <i>Gazzetta</i> , 1912, 42 , ii. 513.
Cu-Fe-Ni	Solid solutions with gap.	R. Vogel, <i>Z.A.</i> , 1910, 67 , 1.
Cu-Mn-Ni	Solid solutions.	N. Parravano, <i>Gazzetta</i> , 1912, 42 , ii. 385.
Cu-Pb-Sn	Partially investigated.	F. Giolitti and M. Marantonio, <i>Gazzetta</i> , 1910, 40 , i. 51.
Cu-Ni-Zn	No ternary compound. Complex changes in solid solution.	V. E. Tafel, <i>M.</i> , 1908, 5 , 413.
Hg-K-Na	? Hg ₂ KNa; max. F.P. at 188°.	E. Jänecke, <i>Z.P.</i> , 1906, 57 , 507.
Mg-Pb-Sn	No ternary compound.	A. von Vegesack, <i>Z.A.</i> , 1907, 54 , 367.
Pb-Sb-Sn	No ternary eutectic.	R. Loebe, <i>M.</i> , 1911, 8 , 7. 33.
Pb-Sn-Zn	Ternary eutectic at 177°.	M. Levi-Malvano and O. Ceccarelli, <i>Gazzetta</i> , 1911, 41 , ii. 269.

VIII

QUATERNARY SYSTEMS.

The tetrahedral space-model of the following system has been determined so far as concerns the liquidus surfaces.

System.	Remarks.	Reference.
Bi-Cd-Pb-Sn	Quaternary eutectic at 70°.	N. Parravano and G. Sirovich, <i>Gazzetta</i> , 1912, 42, i. 630.
Cu-Fe-Mn-Ni	Solid solutions.	N. Parravano, <i>ibid.</i> , 1912, 42, ii. 589.

SUBJECT INDEX

A

Aeolic, 59
Allotropy of iron, 362
Alloys, nature of, 5
—, preparation of, 106, 129
Alternating stress, 350
Alumina, for polishing, 140
Aluminium, alloys of, 396
Amalgams, E.M.F. of, 332
Amorphous modifications of metals, 355
Annealing, 47, 225
Atmosphere for fusion, 102
Atomic concentration, 20
— fall, 21, 329
— percentages, 20
Austenite, 364, 373

B

Bearing-metals, 396
Beck illuminator, 156
Bell-metal, 391
Boiling-points of metals, 108
Brasquing, of crucibles, 105
Brass, 183, 387
—, naval, 388
Brinell's test, 245
Britannia metal, 396
Bronze, 390
—, aluminium, 392
—, manganese, 394
—, plastic, 397
Burnt metals, 228

C

Camera, photographic, 170
Carbide carbon, 362
Carbides, 193
Castings, weakness in, 178
Cast surfaces, 152

Cementation, 110, 217
Cementite, 365, 371
Coercive force, 275
Coinage, 391, 395
Cold junction, 113
Colloidal suspensions, 375
Colonies, 185
Colour filters, 169
— photography, 173
Colours, temper-, 229
Component, definition of, 23
Compounds, formation of, in solid solutions, 62
—, inter-metallic, 32, 64, 337
Conduction, theory of, 251
Conductivity, electrical, 251
—, thermal, 262
Conglomerates, 23
Conjugate alloys, 88
Constantan, 261, 394
Constituents, micrographic, 26
Cooling curve, form of, 13
— curves, methods of plotting, 123 ff.
Copper, alloys of, 387
Cores, 182, 387
Corrosion, 288
Critical curve, 89
— solution temperature, 82
— surface, 89
Crucibles, refractory, 104
Cryohydrates, 22
Crystal grains, 177
Crystallites, 175
Crystallization, 175 ff.
— interval, 46
Crystal skeletons, 175

D

Delta metal, 389
Density, 232
Deoxidation, 107
Derived differential curves, 126

Devitrification, 199
 Diamantine, 140
 Difference methods, 116
 Diffusion, in solids, 46, 216 ff.
 Diffusivity, 217, 334
 Dilatometers, 239
 Direct-rate curves, 125
 Dispersion, ultramicroscopic, 225
 Dissociation on fusion, 336
 — below melting-point, 36
 Duralumin, 396

E

Edges, protection of, 145
 Elastic limit, 341
 — reaction, 246
 Electrolytic potential, 276, 332
 — — of hardened metals, 359
 Emery papers, 136
 Enclosures, mechanical, 195
 Equivalence, coefficient of, 191
 Equilibrium diagram, construction of, 299 ff.
 Etching, electrolytic, 148
 Etching-pits, 179
 Etching reagents, 145
 Eutectic alloys, 21
 — —, structure of, 183
 — point, 16
 — —, ternary, 69
 — times, 18, 307
 Eutectoid, 59, 366
 Exfoliation, 293
 Expansibility, thermal, 238
 Eyepieces, microscopical, 165

F

False equilibrium, 33
 Fatigue, 350
 Ferrite, 369
 Ferromite, 372
 Ferroxyl reagent, 289
 Fers de lance, 374
 Fictitious values, in ternary alloys, 191
 Films, properties of, 358
 Flashing, of gold beads, 198
 Flattening, of maxima, 34, 336
 Flow of metals, 343
 Fractures, 2, 353
 Freedom, degrees of, 24
 Freezing mixtures, 21
 Freezing-point curve, 6, 12, 20
 — —, depression of, 15, 329
 — — surface, 67
 Freezing-points, standard, 114

Furnaces, electric, carbon tube, 98
 — —, granular resistance, 99
 — —, Heraeus, 96
 — —, iridium tube, 98
 — —, Nernst tube, 99
 —, gas, 94
 Fusible metals, 69
 Fusion, change of volume on, 242
 —, latent heat of, 329

G

Galvanizing, 290
 Galvanometers, 114, 118, 213
 German silver, 394
 Glaciers, 226, 344
 Glass, electrolysis of, 220
 Gliding-planes, 347
 Gold, alloys of, 395
 Graphite, 370
 Grinding sections, 136
 Growth of crystals, 176, 226
 Gun-metal, 390

H

Hardening carbon, 362
 Hardness, 243
 Heating curves, 304, 316
 — stage, 149
 Heat of fusion, 13, 329
 — — solution, 296
 Heat-tinting, 148
 Heusler's alloys, 272
 Hydrates, melting of, 36
 Hypertectic point, 200
 Hysteresis, magnetic, 274

I

Ice, plasticity of, 344
 Ideal alloys, 89
 — curve, 330
 Illuminants, 166
 Illumination, oblique, 155
 —, vertical, 156
 Immiscible liquids, 81
 Indentation test, 245
 Industrial alloys, 386 ff.
 Ingots, brittleness of, 178
 Inter-metallic compounds, 32, 64, 337
 — —, conductivity of, 256
 — —, crystallographic characters
 of, 188
 — —, dissociation of, 336
 — —, hardness of, 250
 Inverse-rate curves, 125

Iron, allotropy of, 362
 — carbides, possible, 379
 — -carbon system, 361 ff.
 —, cast-, structure of, 2, 367, 377
 —, technical varieties of, 376
 Isomorphism, 44
 Isothermal lines, 70

J

Japanese swords, metastable state of,
 215
 Journals, metallographic, 9

K

Kamacite, 383
 Kish, 361

L

Labile region, 200
 Lamps, for microscope, 166
 Latent heat, 13, 124, 329
 Lead, alloys of, 395
 Liquid solubility, 81, 312
 Liquidus, 46, 302
 Literature of metallography, 9

M

Magnalium, 396
 Magnetism, 265
 Magnetometer, 266
 Manganin, 394
 Martensite, 374
 Maximum freezing-point, 33
 Méker burner, 95
 Melting, change of volume on, 242
 — under pressure, 357
 Melting-point, 28
 — —, influence of size of grain
 on, 29
 Metals, crystallographic characters
 of, 181
 —, purity of, 130
 Metastable limit, 200
 Meteorites, 3, 383
Micrographia, 2
 Micrographic constituents, 26
 Microsclerometer, 244
 Microscope, construction of, 154
 Micro-sections, 134
 Minimum freezing-point, 50
 Miscibility, partial, 53, 81

Mixed crystals, 7, 44
 Molecular weight of metals, 329 ff.
 Mounting device, 160
 Muntz's metal, 389

N

Naval brass, 389
 Nichrome, 98
 Non-metals, in alloys, 131, 193

O

Objectives, microscopical, 163
 Optical bench, 168
 Organic substances, mixtures of, 200,
 203, 206
 Osmondite, 376
 Oxides, 194
 Oxygen, removal of, from alloys, 107

P

Partition-coefficient, 90
 Patina, on bronze, 391
 Pattinson's process, 31
 Pearlite, 61, 185, 366, 371
 Percussion figures, 349
 Pewter, 395
 Phase, definition of, 23
 — rule, apparent exceptions to, 72
 Phases, doctrine of, 6, 23
 —, limits of, 319
 Phosphor-bronze, 393
 Photography, 172
 — in colours, 173
 Planimetric analysis, 324
 Plasticity, 342
 Platinoid, 261, 395
 Plessite, 384
 Polarization, 277
 Polish-attack, 150
 Polishing machine, 137, 142
 — powder, 140
 — sections, 139
 Polish, nature of, 140, 353
 Polymorphism, 58, 314
 —, effect of, on E.M.F., 285
 Potential, electrolytic, 276
 —, —, effect of strain on, 286
 Potentiometer, 115
 Powders, polishing, 140
 Prism illuminator, 157
 Pyrometers, electrical resistance, 120
 —, optical, 120
 —, radiation, 122
 —, thermo-electric, 111

Q

- Quantity of material, 132
 Quaternary systems, 80
 Quenching, 209 ff., 316

R

- Recalescence, 209
 Recrystallization of hardened metals, 360
 Relief-polishing, 150
 Residues, chemical examination of, 294
 Resistance, electrical, 252
 Röntgen rays, 174
 Rouge, for polishing, 140
 Rusting of iron, 289
 — — —, protection against, 290

S

- Salts, protecting layers of, 106
 Sclerometer, 243
 Scleroscope, 246
 Sections, preparation of, 134
 Segregation in solids, 205, 223, 325
 Shakudo, 391
 Silver, alloys of, 395
 Sintering-point curve, 312
 Skeletons, crystal, 175
 Slag, in steel, 195
 Slip-bands, 346
 Solder, 396
 Solid solutions, 7, 43 ff.
 — — —, crystallization from, 189
 — — —, undercooling of, 206
 Solidus, 46, 305
 Solubility, change of, with temperature, 54
 — — — of liquid phases, 81, 312
 Sorbite, 376
 Space-model, 67
 — — —, sections through, 68
 Speculum metal, 391
 Stage, microscope, 159
 Steel, electrical resistance of, 260
 — — —, expansion of, 241

- Steel, structure of, 376
 Strain, structure due to, 53
 Sulphides, 195
 Superfusion, 197
 Supersolubility curve, 200
 Surface flow, 354
 — — — tension, 226
 Susceptibility, magnetic, 268
 Systems, number of possible, 10

T

- Taenite, 384
 Temperature, influence of, on conductivity, 260
 Temper-carbon, 371
 Tempering, 228
 Ternary alloys, crystallization of, 190
 — — — systems, representation of, 66
 Thermal analysis, 8
 — — — of ternary systems, 76
 Thermit process, 109
 Thermo-couples, 112
 — — — -electric power, 263
 — — — — of hardened metals, 359
 Tie-lines, 88
 Time-composition curve, 18
 Tin, alloys of, 395
 Transformation curves, 314
 Transition temperature, 58
 Triangular diagrams, 66
 Troostite, 375
 Twinning, 183, 345
 Type-metal, 396

U

- Undercooling, 197 ff., 306

V

- Vacuum furnace, 103
 Valency, 338
 Vapour-pressure, 332
 Viscosity, 199
 Volume, specific, 232

NAME INDEX

Figures in italics refer to the Appendix

A

Adams, F. D., 345
 Adams, L. H., 232
 Adler, E., 211
 Andrew, J. H., 311, 416
 Andrews, T., 8, 286
 Archbutt, S. L., 8, 404
 Arnold, J. O., 7, 8, 126, 218, 375, 378
 Arpi, R., 29
 Arrivaut, G., 400
 Ashley, H. E., 405
 Asteroth, P., 272
 Aten, A. H. W., 69, 336
 Aubel, E. van, 236, 263
 Auerbach, F., 245
 Avenarius, R., 264

B

Baikoff, A., 187, 196, 257, 374, 409
 Baker, T. J., 297
 Bancroft, W. D., 9, 68, 90, 310
 Baraduc-Muller, L., 106
 Barlow, W., 181
 Barlow, W. E., 416
 Barrett, W. F., 209, 259, 274
 Bartells, G. C., 291
 Barus, C., 6, 229, 254, 287, 359
 Bauer, O., 107, 196, 286, 325, 376,
 379, 415
 Baumhauer, H., 179
 Behr, G. E., 287
 Behrens, H., 8
 Beilby, G. T., 53, 140, 354, 356, 357,
 358, 360
 Bell, J. M., 80
 Belynsky, S. W., 409
 Benedicks, C., 29, 148, 158, 185, 211,
 213, 225, 249, 259, 286, 368, 372,
 375, 379, 385
 Bengough, G. D., 226, 360, 388
 Bennigson, F., 108, 414
 Bent, L. N., 289

Berthelot, M., 359
 Berwerth, F., 384
 Bijl, H., 55, 239, 279, 312, 402
 Bijlert, A. van, 310
 Blough, E., 318
 Blount, B., 157
 Blyth, T. A., 2
 Boecke, H. E., 384
 Bonnerot, S., 218
 Bornemann, K., 11, 262
 Bossuet, P., 405
 Bottone, S., 248
 Boudonard, O., 195
 Boynton, H. C., 245, 375
 Braune, H., 195
 Breuil, P., 148
 Brinell, J. A., 245
 Broniewski, W., 265
 Brown, J. H., 289
 Brown, W., 259, 274
 Browne, A. W., 69
 Brunck, O., 404
 Bruni, G., 9, 44, 69, 222, 406, 417
 Brunner, E., 288
 Burgess, G. K., 121, 123, 125
 Buss, A., 99

C

Callendar, H. L., 120
 Campbell, E. D., 298, 379
 Campbell, W., 8, 152, 181
 Carpenter, H. C. H., 8, 59, 62, 99,
 117, 225, 362, 378, 390, 392, 406,
 407, 416
 Cartaud, G., 140, 182, 271, 317, 349,
 350, 354, 369
 Ceccarelli, O., 293, 417
 Cederholm, A. M., 289
 Cesaris, P. de, 414
 Charpy, G., 8, 70, 218, 226, 241, 367,
 368, 371, 389, 397, 417
 Chaucer, G., 5
 Chikashigé, M., 408, 409

Chwolson, O. D., 242
 Clamer, G. H., 313
 Clay, J., 261
 Coehn, A., 284
 Cohen, E., 215, 239, 285
 Colson, A., 220
 Colver-Glavert, E., 148
 Coppet, de, 22
 Cowper-Coles, S., 110, 219
 Cross, W., 187
 Curie, M. S., 268, 271
 Curie, P., 270
 Curry, B. E., 293, 316, 392, 407
 Cushman, A. S., 289

D

Daubrée, G. A., 345
 Day, A. L., 112, 114, 132, 264
 Deckert, 99
 Degens, P. N., 401
 Dejean, P., 126, 305
 De la Rue, W., 178
 Desch, C. H., 178, 187, 204, 216,
 238, 307, 320, 325, 337, 415
 Dewar, Sir J., 261, 264, 270
 Diesselhorst, H., 262, 264
 Dobbelstein, 382
 Döbereiner, J. W., 22, 296
 Doerinckel, F., 48, 401, 403, 404, 411,
 413
 Donnan, F., 23
 Doński, L., 406, 408, 414, 415
 Drude, P., 251
 du Bois, H., 265, 268
 Dumas, L., 272
 Dumont, E., 272
 Dunstan, W. R., 289

E

Edelmann, M., 213
 Edwards, C. A., 8, 62, 311, 377, 390,
 392, 407, 416
 Efremoff, N. N., 416
 Ellingen, K., 383
 Ericson-Aurén, T., 288
 Erman, 209
 Ewing, J. A., 152, 180, 268, 274, 346,
 350, 358
 Eyk, C. van, 215, 285, 310

F

Fahrenheit, G. D., 197
 Faraday, M., 219, 358
 Fassbender, H., 272

Faust, O., 358
 Fawsitt, C. E., 199, 286, 359
 Fay, H., 333, 405
 Fedoroff, A. S., 406
 Féry, C., 122, 123
 Field, S., 111
 Findlay, A., 6, 23, 24, 81, 239, 336
 Fischer, F., 284
 Fleming, J. A., 261, 264, 270, 272
 Foerster, F., 378
 Forbes, J. D., 344
 Forsythe, W. J., 103
 Fraenkel, W., 384, 400
 Frankenheim, 123
 Franz, R., 262
 Fréminville, R. de, 246
 Frémont, C., 349
 Friedrich, K., 9, 31, 57, 90, 91, 98,
 99, 108, 308, 399, 400, 403, 407,
 413, 414, 416
 Friend, J. N., 289, 340
 Fromm, O., 111, 284

G

Galt, A., 297
 Gautier, H., 12
 Geer, W. C., 69
 Gibbs, W., 6, 66
 Gillson, G., 405
 Giolitti, F., 61, 151, 218, 293, 318,
 409, 417
 Giraud, 204
 Gladstone, J. H., 297
 Goerens, P., 29, 69, 147, 173, 211,
 362, 366, 370, 382, 383
 Goldschmidt, H., 109
 Goldschmidt, V., 179
 Gontermann, W., 382, 400
 Gore, G., 209
 Goulding, E., 289
 Gowland, W., 8
 Gray, A., 272
 Gray, J. G., 267, 272
 Green, C. F., 324
 Greenwood, H. C., 109
 Grenet, L., 241, 367
 Griffiths, C., 218
 Griffiths, E. H., 120
 Groth, P., 189, 371
 Grube, G., 35, 404, 405, 411
 Grüneisen, E., 262
 Guertler, W., 11, 225, 253, 255, 260,
 270, 295, 317, 401, 410, 412, 415
 Guillaume, C. E., 272
 Guillemin, G., 8
 Guillet, L., 191, 218, 293, 382, 383,
 392, 412
 Gulliver, G. H., 349

Guthrie, F., 16, 22, 334
 Gutowsky, N., 311, 364
 Gwyer, A. G. C., 392, 400, 403, 404,
 406, 407

H

Haber, F., 333
 Hadfield, R. A., 7, 8, 259, 271, 272,
 274, 382
 Hagenbach, E., 226
 Haken, W., 265
 Hall, J., 345
 Hallock, W., 219
 Hampe, W., 195
 Hannover, H. J., 152
 Harker, J., 98, 99, 112
 Harkort, H., 100, 119, 362, 415
 Hartley, H., 200
 Haupt, E., 266, 272
 Heimstädt, O., 162
 Heraeus, W. C., 98
 Herschel, J., 354
 Herschkowitsch, M., 277, 297
 Hess, G. H., 297
 Heteren, W. J. van, 400
 Heusler, F., 266, 272, 273
 Heycock, C. T., 6, 7, 12, 21, 31, 57,
 61, 69, 83, 120, 147, 174, 303, 311,
 318, 330, 403, 406, 409
 Heyn, E., 107, 147, 161, 167, 180,
 194, 196, 204, 286, 325, 348, 368,
 376, 379, 415
 Hilpert, S., 148
 Hindrichs, G., 400, 402, 403, 406, 407
 Hoff, J. H. van't, 43, 329
 Hoffmann, F., 66
 Hofman, H. O., 324
 Hofmeier, F., 91, 285, 416
 Hogg, T. W., 272
 Holborn, L., 112, 121, 123, 264
 Holzmann, M., 251
 Homberg, 220
 Honda, K., 273
 Hooke, R., 2, 354
 Hopkinson, J., 260, 272
 Howe, H. M., 7, 59, 185, 229, 362,
 369, 376
 Howe, P. E., 291
 Howell, J. H., 220
 Hudson, O. F., 226, 388
 Hulet, G. A., 224
 Humfrey, J. C. W., 103, 152, 180,
 226, 350, 363
 Humphreys, W., 334
 Huntington, A. K., 145, 178, 204,
 325, 415
 Hutchinson, G. A., 200
 Huxley, T. H., 344

I

Iddings, J. P., 187
 Iljin, N., 368
 Isaac, E., 402, 403, 410, 415
 Isaac, F., 200, 203, 206
 Ischewsky, 146

J

Jackson, H., 157
 Jaeger, W., 262, 264
 Jänecke, E., 34, 40, 66, 73, 76, 128,
 400, 410, 416, 417
 Jaggar, T. A., 244
 Jefferson, J., 8
 Jeriomin, K., 304, 400
 Johnston, J., 232, 357
 Jones, B. M., 200
 Jones, E. T., 269
 Jowett, H. A. D., 289
 Jüptner von Jonstorff, H. von, 6

K

Kahlbaum, G. W. A., 232
 Kahlenberg, L., 111
 Kaiser, W., 387
 Kamensky, G., 6, 257
 Kaneko, K., 194
 Kanewsky, I., 400
 Kapp, A., 6, 400
 Karsten, 91
 Keeling, B. F. E., 59, 117, 378
 Kennedy, M. B., 379
 Kerp, W., 111
 Kick, 345
 Klaassen, H. G., 268
 Klein, D., 291
 Knowlton, A. A., 272
 Kobayshi, M., 404, 405
 Koch, 199
 Koenigsberger, J., 265
 Konstantinoff, N., 189, 206, 236, 408,
 410, 415, 416
 Kremann, R., 91, 285, 303, 313, 336,
 416
 Kriloff, B. B., 69
 Kroll, A., 381
 Krumbhaar, W., 194
 Kurbatoff, W. J., 146, 148, 375
 Kurlbaum, F., 121
 Kurnakoff, N. S., 9, 34, 35, 48, 52,
 86, 115, 152, 189, 206, 236, 244,
 249, 251, 339, 400, 401, 402, 404,
 405, 408, 410, 411, 412
 Kusnetzoff, A. N., 86, 408

L

- Laar, J. J. van, 49, 331
 Lambert, B., 289
 Lange, E. F., 176, 223
 Lantsberry, F. C. H., 8
 Laschtschenko, P. N., 281, 413
 Laurie, A. P., 277
 Lantsch, 415
 Law, E. F., 173
 Lebeau, P., 405, 409
 Le Chatelier, A., 360
 Le Chatelier, H., 6, 8, 9, 118, 141,
 148, 151, 161, 167, 194, 211, 213,
 238, 240, 246, 331
 Ledebur, A., 372
 Lehmann, O., 175, 176, 345, 348
 Leon, J. T., 88
 Lepkowski, W. von, 58, 399
 Leroux, A., 57, 91, 108, 399, 403,
 413, 414, 416
 Levi-Malvano, M., 390, 417
 Levin, M., 30, 271, 317, 400, 401
 Levol, A., 5, 22, 198
 Lewis, G., 333
 Lewkonja, K., 64, 402, 403, 405, 409,
 415
 Liebenow, C., 252
 Liebknecht, O., 265
 Lincoln, A. T., 291
 Loebe, R., 417
 Longmuir, P., 8
 Lorentz, H. A., 336
 Lossew, K., 412
 Lowitz, J. T., 198
 Luginin, W. F., 297
 Lussana, S., 341
 Luther, R., 239, 283, 284

M

- Maclean, M., 360
 McWilliam, A., 218
 Maey, E., 234, 236
 Mallock, A., 349
 Mannesmann, R., 218
 Marantonio, M., 390, 417
 Marsden, R. S., 220
 Martens, A., 4, 161, 167, 244, 250
 Mascarelli, L., 69
 Masing, G., 222, 411
 Mathewson, C. H., 86, 399, 403, 404,
 408, 412
 Matthiessen, A., 6, 53, 58, 234, 238,
 251, 254, 260
 Mattonet, F., 99
 Maurer, E., 248, 275, 373, 375
 Maxwell, J. C., 66
 Mazzotto, D., 331, 401

- Meerburg, P. A., 89
 Meneghini, D., 222
 Metz, de, 264
 Meyer, E., 246
 Meyer, G., 332
 Meyer, H., 366
 Meyer, S., 265
 Miers, H. A., 180, 200, 203, 206
 Milton, J. T., 391
 Mönkemeyer, K., 404, 413
 Moody, G. T., 288, 290
 Morris, D. K., 270
 Mütge, O., 345
 Müller, A., 103
 Müller, P., 262
 Müller, W., 131
 Muir, J., 352
 Mylius, F., 111, 284, 378

N

- Nacken, R., 63, 64
 Nernst, W., 278
 Neville, T. H., 6, 7, 12, 21, 31, 57,
 61, 69, 83, 120, 147, 174, 303, 311,
 318, 330, 337, 403, 406, 409
 Nicolson, J. H., 345
 North, E., 333

O

- Oberhoffer, P., 103
 Offer, 22
 Ogg, A., 414
 Omodei, D., 242
 Orthey, M., 382
 Osmond, F., 2, 4, 7, 8, 126, 140, 150,
 182, 218, 271, 317, 349, 350, 354,
 369, 374, 375, 384
 Ostermann, H., 275
 Ostwald, W., 198, 200, 239, 283

P

- Paillot, R., 263
 Palmacr, W., 288
 Parkes, 91
 Parravano, N., 69, 80, 401, 414, 416,
 417, 418
 Paschsky, N. P., 281, 413
 Pattinson, 31
 Pellini, G., 404, 406, 412
 Perkin, F. M., 110
 Perrot, L., 263
 Person, 209, 296
 Petrenko, G. J., 31, 91, 399, 400, 402,
 403, 404, 405, 406

Pfaundler, L., 22
 Pfeiffer, V. O., 132
 Philip, A., 393
 Philips, M., 294
 Pick, H., 287
 Plato, W., 13, 48, 101, 124, 309
 Podkopaëff, N., 413
 Ponsot, A., 23
 Pope, W. J., 181
 Portevin, A., 101, 227, 360, 400
 Pöschl, V., 244
 Potdar, G. N., 90, 91
 Poynting, J. H., 357
 Pratt, L., 110
 Preuss, E., 246
 Pushin, N. A., 55, 152, 249, 281, 400,
 401, 402, 404, 405, 411, 412, 413

Q

Quasebart, C., 403
 Quercigh, E., 9, 399, 404, 406, 412,
 417
 Quincke, G., 177

R

Ramsay, Sir W., 6, 332
 Raoult, F. M., 6, 20
 Rauschenplat, G. von, 262
 Rayleigh, Lord, 140, 252, 354
 Read, A. A., 378
 Réaumur, R. A. F. de, 2, 21
 Reichardt, G., 256
 Reinders, W., 277, 413
 Retgers, J. W., 235
 Rhodin, G. J. A., 291
 Richards, T. W., 287, 333
 Richarz, F., 272
 Reimsdyk, A. D. van, 198
 Reitzsch, A., 263
 Riley, J., 132
 Rinne, F., 384
 Roberts-Austen, W. C., 7, 8, 52, 115,
 117, 194, 198, 216, 218, 220, 334,
 361, 391, 395, 401, 404
 Rogers, F., 349, 375
 Röhl, G., 195
 Romanoff, L., 82, 403
 Roozeboom, H. B., 7, 12, 13, 43, 44,
 53, 55, 59, 69, 362
 Rose, T. K., 52, 401
 Rosenhain, W., 8, 70, 101, 125, 142,
 145, 152, 160, 163, 180, 212, 302,
 307, 346, 348, 363, 401
 Ross, A. D., 267, 272
 Roth, K., 232
 Rowland, W. S., 293

Royston, G. P., 379
 Rudberg, F., 401
 Rudolfi, E., 295, 409
 Rüdorff, F., 21, 22
 Ruer, R., 53, 72, 194, 271, 336, 368,
 383, 401, 413, 415
 Ruff, O., 369
 Ruskin, J., 344
 Rykowkoff, A., 50, 53, 402

S

Sabersky, E., 211
 Sackur, O., 287
 Sahmen, R., 52, 76, 131, 241, 402,
 408, 409
 Saklatwalla, B., 362
 Saladin, 118
 Sand, H. J. S., 284
 Sander, W., 413
 Sandonnini, G., 9, 417
 Saniter, E. H., 210, 378
 Saposchnikoff, A. V., 400
 Sauveur, A., 28, 324
 Schaffgotsch, F. S., 123
 Schemtschuschny, S. F., 48, 50, 52,
 53, 208, 244, 249, 402, 406, 409,
 413, 415, 416
 Schenck, R., 251, 253
 Schepeleff, J., 415
 Schleicher, A. P., 400, 417
 Schoen, P., 414
 Schöller, A., 333
 Schöne, G., 378
 Schreibers, 3
 Schreinemakers, F. A. H., 69
 Schröder, I., 331
 Schükareff, A., 297
 Schüller, A., 34, 410
 Schukowsky, G. U., 409, 411
 Schulze, F. A., 263
 Schüz, E., 415
 Senkowsky, N., 249
 Shepard, C. U., 371
 Shepherd, E. S., 9, 62, 69, 70, 318,
 388, 400, 404, 410
 Shore, A. F., 246
 Siedler, P., 232
 Sieverts, A., 194
 Sirovich, G., 69, 80, 418
 Smirnof, W. J., 251
 Smith, D. P., 403, 408, 411
 Smith, G. McP., 333, 334
 Smith, S. W. J., 284
 Smits, A., 369
 Sorby, H. C., 3, 185
 Sosman, R. B., 114, 132
 Spencer, L. J., 371

Spring, W., 30, 82, 209, 217, 219,
232, 286, 331, 343, 403
Springer, J. F., 246
Stansfield, A., 115
Stanton, T. E., 353
Stark, W., 266
Stead, J. E., 8, 131, 138, 148, 157,
160, 167, 181, 185, 187, 205, 223,
226, 379, 413
Stein, S., 4
Stepanoff, N. J., 252, 404, 405
Stock, A., 312
Stodart, 219
Stoffel, A., 400, 417
Stokes, G. G., 66, 88, 89
Stoney, J., 157
Stortenbecker, W., 336
Stromeyer, C. E., 194, 379
Stronhal, V., 6, 229, 254
Sturm, E., 232
Sucheni, A., 281, 404
Suschtschinsky, P. von, 189
Svedelius, G. E., 240

T

Tafel, V. E., 62, 305, 388, 410, 412,
417
Take, E., 272
Tamaru, S., 401, 403, 415
Tammann, G., 6, 8, 13, 18, 33, 64,
76, 86, 200, 226, 241, 270, 271, 307,
310, 317, 329, 339, 343, 358, 384,
401, 402, 403, 404, 411, 412, 415
Tavanti, G., 61, 318, 409
Teall, J. H., 187
Tegetmeier, F., 220
Tholander, H., 194
Thomas, N. G., 200
Thompson, C., 66, 88, 91
Thomson, J. C., 289
Töpler, M., 242
Tomlinson, H., 272
Traube, I., 249
Treitschke, W., 206, 408, 415
Tresca, 343
Tschernoff, D., 5, 176
Tucker, P. A., 70, 142, 302, 401
Turner, T., 243, 248, 359
Tyndall, J., 344

U

Upton, G. B., 378
Urazoff, G. G., 50, 53, 250, 402, 407,
409

V

Valentiner, S., 121
Vanstone, E., 410
Vege sack, A. von, 76, 403, 415, 417
Veit, T., 273
Vincentini, G., 242
Violle, J., 220
Viviani, E., 401, 417
Vogel, R., 39, 185, 310, 400, 402,
404, 405, 407, 417
Vogt, C., 251
Voss, G., 40, 402, 403, 407, 408, 411,
412, 415

W

Wahlberg, A., 246
Wahl, W., 400
Waidner, C. W., 123
Walker, W. H., 289
Wanner, 121
Warburg, E., 220, 274
Warrington, R., 209
Wark, N. J., 365, 374
Watts, O. P., 403
Wedding, H., 4, 131
Wedekind, E., 273
Weinschenk, E., 371
Wertb, J., 4
Weyl, F., 218
White, W. P., 115
Whiteley, W., 406
Whitney, W. R., 289
Widmanstätten, A. J. F. X. von, 3,
383
Wilm, A., 396
Wiedemann, G., 262
Wien, W., 121
Williams, R. S., 401, 403, 405, 409,
411, 413
Willows, R. S., 253
Wills, A. P., 265
Wirkner, C. G. von, 21
Wöhler, F., 350
Wogau, M. von, 334
Wologdine, S., 52, 106, 115, 196
Woods, S. H., 392
Wright, C. R. A., 68, 82, 88, 91
Wüst, F., 9, 103, 126, 173, 382

Y

Yerxa, R. B., 324

INDEX OF SYSTEMS

Figures in italics refer to the Appendix

- Aluminium-antimony, 33, 236, 404
 — -bismuth, 403
 — -cadmium, 403
 — -calcium, 406
 — -chromium, 406
 — -cobalt, 406
 — -copper, 274, 294, 392, 407
 — -copper-manganese, 272
 — -copper-tin, 416
 — -copper-zinc, 416
 — -gold, 144, 406
 — -iron, 404
 — -lead, 81, 403
 — -magnesium, 265, 395, 404
 — -manganese, 407
 — -nickel, 407
 — -potassium, 403
 — -silicon, 400
 — -silver, 405
 — -sodium, 403
 — -thallium, 403
 — -tin, 400
 — -zinc, 404
- Antimony-arsenic, 414
 — -bismuth, 282, 401
 — -bismuth-copper, 417
 — -cadmium, 206, 408
 — -cadmium-copper, 417
 — -calcium, 415
 — -chromium, 409
 — -cobalt, 409
 — -copper, 144, 184, 187, 257, 409
 — -gold, 39, 309, 404
 — -iron, 235, 410
 — -lead, 234, 395, 400
 — -lead-tin, 131, 417
 — -magnesium, 405
 — -manganese, 411
 — -nickel, 283, 412
 — -palladium, 413
 — -silicon, 401
 — -silver, 404
 — -sodium, 412
 — -tellurium, 265, 405
- Antimony-thallium, 405
 — -tin, 395, 413
 — -zinc, 208, 236, 413
- Arsenic-bismuth, 403
 — -cobalt, 414
 — -copper, 407
 — -iron, 414
 — -lead, 414
 — -manganese, 414
 — -nickel, 414
 — -platinum, 414
 — -silver, 414
 — -tin, 414
 — -zinc, 414
- Bismuth-cadmium, 234, 400
 — -cadmium-lead, 416
 — -cadmium-lead-tin, 418
 — -cadmium-tin, 417
 — -calcium, 414
 — -chromium, 403
 — -cobalt, 403
 — -copper, 351, 400
 — -gold, 400
 — -iron, 403
 — -lead, 186, 296, 400
 — -lead-mercury-tin, 295
 — -lead-tin, 70, 191, 417
 — -magnesium, 404
 — -manganese, 273
 — -mercury, 400
 — -nickel, 408
 — -potassium, 408
 — -silicon, 403
 — -silver, 234, 399
 — -sodium, 408
 — -tellurium, 265, 404
 — -thallium, 222, 408
 — -tin, 186, 234, 400
 — -zinc, 82, 403
- Cadmium-calcium, 408
 — -chromium, 403
 — -copper, 408
 — -gold, 407

- Cadmium-iron, 403
 — lead, 73, 234, 400
 — lead-mercury, 73, 417
 — lead-tin, 417
 — magnesium, 404
 — magnesium-zinc, 417
 — mercury, 55, 280, 402
 — mercury-sodium, 417
 — nickel, 415
 — potassium, 408
 — silver, 406
 — sodium, 86, 408
 — tellurium, 404
 — thallium, 400
 — tin, 225, 234, 400
 — zinc, 400
- Caesium-mercury, 409
 Calcium-copper, 415
 — iron, 403
 — lead, 415
 — silicon, 415
 — thallium, 415
 — tin, 415
 — zinc, 408
- Carbon-iron, 7, 59, 209, 217, 223, 228, 241, 259, 361 ff.
 — iron-manganese, 382
 — iron-phosphorus, 382
 — iron-silicon, 382
- Chromium-cobalt, 402
 — copper, 403
 — iron, 415
 — lead, 403
 — nickel, 402
 — silver, 402
 — tin, 403
 — zinc, 403
- Cobalt-copper, 256, 402
 — gold, 400
 — iron, 401
 — lead, 403
 — nickel, 270, 401
 — phosphorus, 415
 — silicon, 409
 — silver, 402
 — thallium, 403
 — tin, 409
 — zinc, 415
- Copper-gold, 52, 249, 395, 402
 — gold-silver, 416
 — iron, 131, 394, 402
 — iron-manganese, 417
 — iron-manganese-nickel, 418
 — iron-nickel, 417
 — lead, 83, 397, 403
 — lead-silver, 91, 416
 — lead-tin, 417
 — magnesium, 409
 — manganese, 50, 394, 402
 — manganese-nickel, 417
- Copper-nickel, 48, 222, 249, 255, 262, 393, 401
 — nickel-zinc, 305, 394, 417
 — oxygen, 204
 — phosphorus, 185, 204, 325, 397, 415
 — phosphorus-tin, 393
 — palladium, 401
 — platinum, 401
 — silicon, 294, 409
 — silver, 57, 183, 186, 249, 256, 395, 399
 — tellurium, 409
 — thallium, 403
 — tin, 61, 236, 250, 293, 318, 390, 409
 — tin-zinc, 191, 389
 — zinc, 62, 190, 221, 225, 227, 287, 290, 297, 387, 410
- Gold-iron, 402
 — lead, 216, 407
 — magnesium, 407
 — nickel, 271, 400
 — palladium, 401
 — palladium-platinum, 73
 — platinum, 48, 401
 — silver, 217, 235, 249, 254, 395, 401
 — sodium, 404
 — tellurium, 404
 — thallium, 30, 400
 — tin, 407
 — zinc, 407
- Indium-lead, 401
 — thallium, 402
- Iridium-platinum, 235
- Iron-lead, 403
 — manganese, 271, 380, 401
 — molybdenum, 415
 — nickel, 225, 271, 383, 415
 — phosphorus, 205, 224, 415
 — platinum, 219, 415
 — silicon, 410
 — silver, 402
 — thallium, 403
 — tin, 410
 — tungsten, 415
 — vanadium, 402
 — zinc, 219, 415
- Lead-magnesium, 404
 — magnesium-tin, 76, 417
 — manganese, 403
 — mercury, 234, 400
 — nickel, 403
 — palladium, 413
 — platinum, 283, 413
 — potassium, 411

- Lead-silicon, 403
 — -silver, 31, 234, 400
 — -silver-tin, 416
 — -silver-zinc, 91, 416
 — -sodium, 397, 412
 — -tellurium, 405
 — -thallium, 405
 — -tin, 29, 234, 262, 284, 396, 401
 — -tin-zinc, 87, 417
 — -zinc, 82, 403
 Lithium-tin, 411
- Magnesium-nickel, 40, 411
 — -potassium, 403
 — -silicon, 405
 — -silver, 265, 406
 — -sodium, 403
 — -thallium, 411
 — -tin, 35, 405
 — -zinc, 405
- Manganese-nickel, 53, 402
 — -phosphorus, 416
 — -silicon, 411
 — -silver, 251, 402
 — -tin, 411
- Mercury-potassium, 34, 42, 410
 — -potassium-sodium, 417
 — -rubidium, 411
 — -silver, 414
 — -sodium, 34, 410
 — -tellurium, 404
 — -thallium, 281, 404
- Mercury-tin, 234, 400
 — -zinc, 400
- Nickel-phosphorus, 186, 416
 — -silicon, 412
 — -silver, 403
 — -thallium, 403
 — -tin, 412
 — -zinc, 412
- Palladium-silver, 401
 Platinum-silver, 404
 — -tin, 413
 Potassium-sodium, 404
 — -thallium, 411
 — -tin, 411
 — -zinc, 411
- Selenium-silver, 413
 Silicon-silver, 400
 — -thallium, 403
 — -tin, 401
 Silver-sodium, 399
 Silver-tellurium, 406
 — -thallium, 400
 — -tin, 236, 404
 — -zinc, 236, 406
- Sodium-tellurium, 412
 — -thallium, 412
 — -tin, 412
 — -zinc, 412
- Tellurium-tin, 405
 — -zinc, 405
- Thallium-tin, 401
 — -zinc, 403
- Tin-zinc, 234, 401

THE END

PRINTED BY
WILLIAM CLOWES AND SONS, LIMITED,
LONDON AND BECCLES.

